

F9.9MLHB 2003 / TOP COWLING

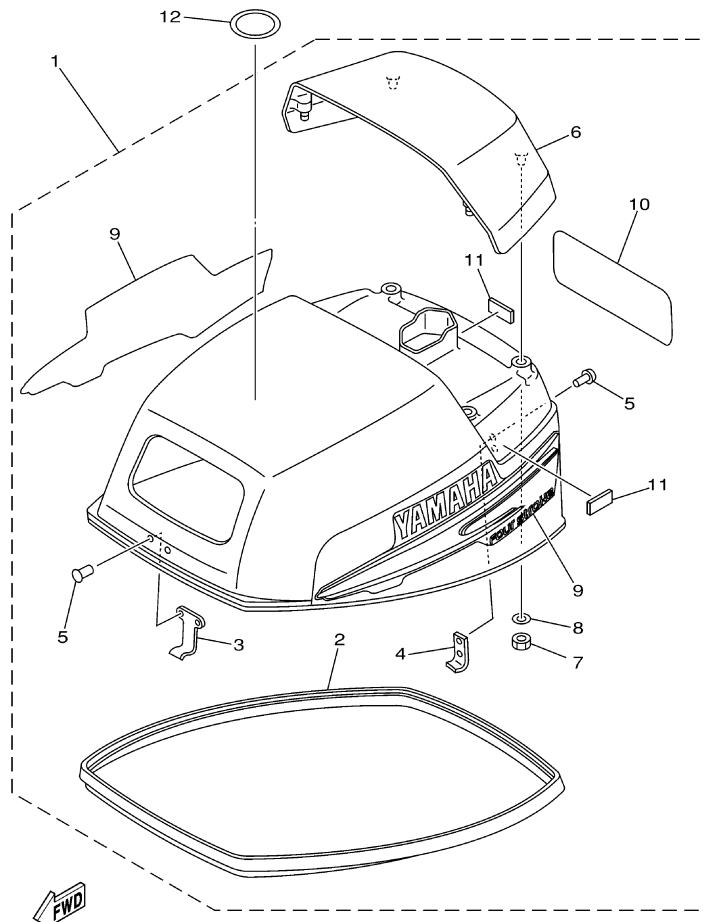

6G91100-2010

Part List

F9.9MLHB 2003 / TOP COWLING

REF - NO	PART NUMBER	PART NAME	QUANTITY	REMARKS
1	6G9-42610-20-4D	TOP COWLING ASSY	1	
2	6G8-42615-01-00	.SEAL	1	
3	6G8-42651-00-00	.HOOK	1	
4	6G8-42652-00-00	.HOOK	1	
5	90266-04M04-00	.RIVET	4	
6	6G8-42613-01-4D	.MOLDING, AIR DUCT	1	
7	95303-06700-00	.NUT	4	
8	92903-06200-00	.WASHER, PLAIN	4	
9	6G9-W0070-30-00	.GRAPHIC SET	1	
10	6G9-42678-30-00	.GRAPHIC, REAR	1	
11	6G8-42662-00-00	.DAMPER	3	
12	67F-13434-02-00	LABEL, CAUTION	1	

F9.9MLHB 2003 / CYLINDER CRANKCASE

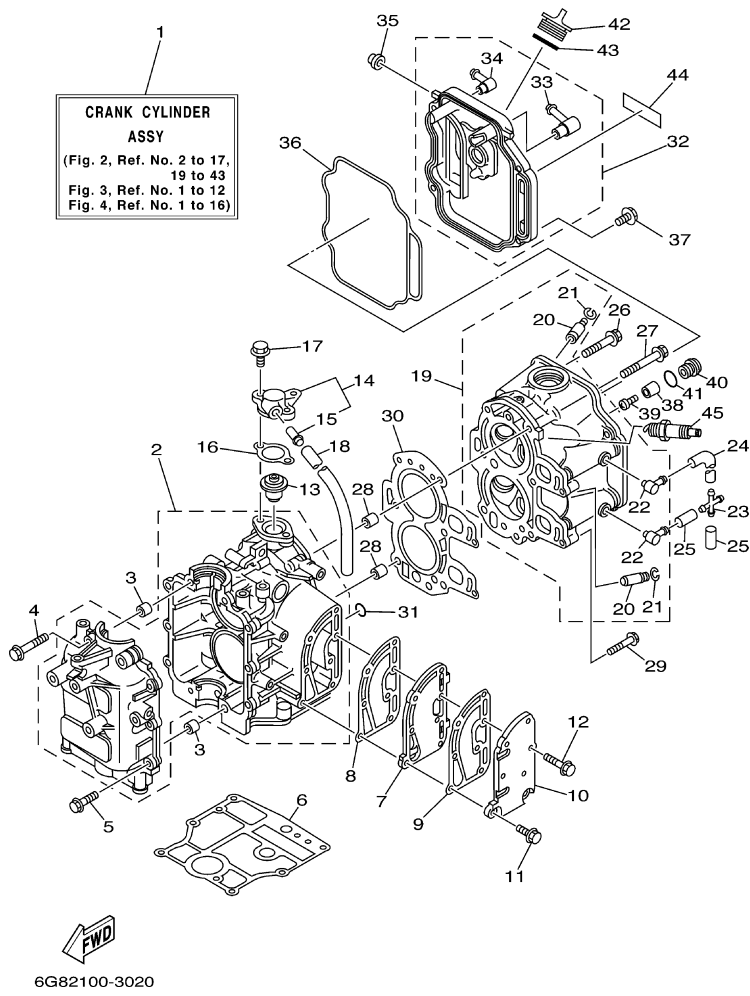

©2014 Yamaha Motor Corporation, U.S.A. All rights reserved.

Part List

F9.9MLHB 2003 / CYLINDER CRANKCASE

REF - NO	PART NUMBER	PART NAME	QUANTITY	REMARKS
1	6G8-W0090-34-1S	CRANK CYLINDER ASSY	1	
2	6G8-15100-05-1S	CRANKCASE ASSY	1	
3	99510-10114-00	PIN, DOWEL	2	
4	90119-08M18-00	BOLT, WITH WASHER	4	
5	90119-06M12-00	BOLT, WITH WASHER	6	
6	6G8-11351-A0-00	GASKET, CYLINDER	1	
7	6G8-41111-02-1S	INNER COVER, EXHAUST	1	
8	6G8-41112-02-00	GASKET, EXHAUST INNER COVER	1	
9	6G8-41114-00-00	GASKET, EXHAUST OUTER COVER	1	
10	6G8-41113-10-1S	OUTER COVER, EXHAUST	1	
11	90119-06MA3-00	BOLT, WITH WASHER	2	
12	90119-06MA4-00	BOLT, WITH WASHER	5	
13	6G8-12411-02-00	THERMOSTAT	1	
14	6G8-12413-00-1S	COVER, THERMOSTAT	1	
15	6E5-24377-00-00	.PIPE, JOINT 2	1	
16	6G8-12414-A0-00	.GASKET, COVER	1	
17	90119-06MA2-00	BOLT, WITH WASHER	2	
18	90445-11M66-00	.HOSE (L410)	1	
19	6G8-11111-03-1S	HEAD, CYLINDER 1	1	
20	6G8-11133-10-00	.GUIDE, VALVE 1	4	
21	93450-09M01-00	.CIRCLIP	4	
22	676-11372-00-00	.NIPPLE, HOSE	2	
23	6G9-24379-00-00	PIPE, JOINT 4	1	
24	6G8-12481-01-00	PIPE 1	1	
25	90445-09220-00	HOSE (L30)	2	
26	90105-08M37-00	BOLT, FLANGE	3	
27	90105-08M36-00	BOLT, FLANGE	3	
28	99510-10114-00	PIN, DOWEL	2	
29	90119-06MA5-00	BOLT, WITH WASHER	2	
30	6G8-11181-A1-00	GASKET, CYLINDER HEAD 1	1	
31	93210-11M59-00	O-RING	1	
32	6G8-11191-01-1S	COVER, CYLINDER HEAD 1	1	
33	6G8-15373-01-00	.PIPE, BREATHER	1	
34	676-11372-00-00	.NIPPLE, HOSE	1	
35	6G8-81336-00-00	GROMMET	2	
36	6G8-11356-00-00	SEAL, CYLINDER 2	1	
37	90119-06MA2-00	BOLT, WITH WASHER	4	
38	6G8-11325-00-00	ANODE	1	
39	97880-05025-00	SCREW, PAN HEAD	1	
40	6G8-11197-01-00	PLUG, BLIND	1	
41	93210-13M63-00	.O-RING	1	
42	6G8-15363-00-00	PLUG, OIL	1	
43	93210-24M79-00	.O-RING	1	
44	6G9-12138-40-00	MARK, CAUTION	1	
45	94701-00282-00	PLUG SPARK (NGK CR6HS)	2	

F9.9MLHB 2003 / CRANKSHAFT PISTON

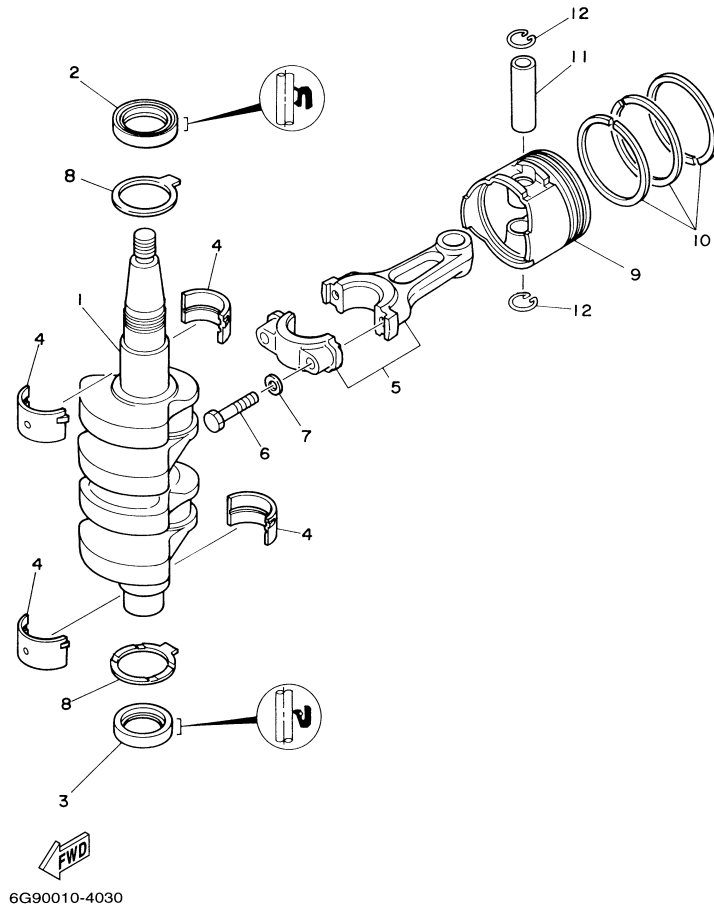

©2014 Yamaha Motor Corporation, U.S.A. All rights reserved.

Part List

F9.9MLHB 2003 / CRANKSHAFT PISTON

REF - NO	PART NUMBER	PART NAME	QUANTITY	REMARKS
1	6G8-11411-04-00	CRANKSHAFT	1	
2	93102-30M22-00	.OIL SEAL	1	
3	93101-25M24-00	OIL SEAL	1	
4	6G8-11416-00-00	PLANE BEARING, CRANKSHAFT 1	4	UR BROWN
4	6G8-11416-20-00	PLANE BEARING, CRANKSHAFT 1	4	UR BLUE
4	6G8-11416-10-00	PLANE BEARING, CRANKSHAFT 1	4	UR BLACK
5	6G8-11650-03-00	CONNECTING ROD ASSY	2	
6	6G8-11654-00-00	BOLT, CONNECTING ROD	4	
7	90201-06M00-00	WASHER, PLATE	4	
8	6G8-11426-00-00	PLANE BEARING, CRANKSHAFT 1	2	
9	6G8-11631-03-96	PISTON (STD)	2	
9	6G8-11635-03-00	PISTON (0.25MM O/S)	2	AP
9	6G8-11636-03-00	PISTON (0.50MM O/S)	2	AP
10	6G8-11610-22-00	PISTON RING SET (0.50MM O/S)	2	AP
10	6G8-11610-12-00	PISTON RING SET (0.25MM O/S)	2	AP
10	6G8-11610-02-00	PISTON RING SET (STD)	2	
11	634-11633-00-00	PIN, PISTON	2	
12	93450-15023-00	CIRCLIP	4	

F9.9MLHB 2003 / VALVE

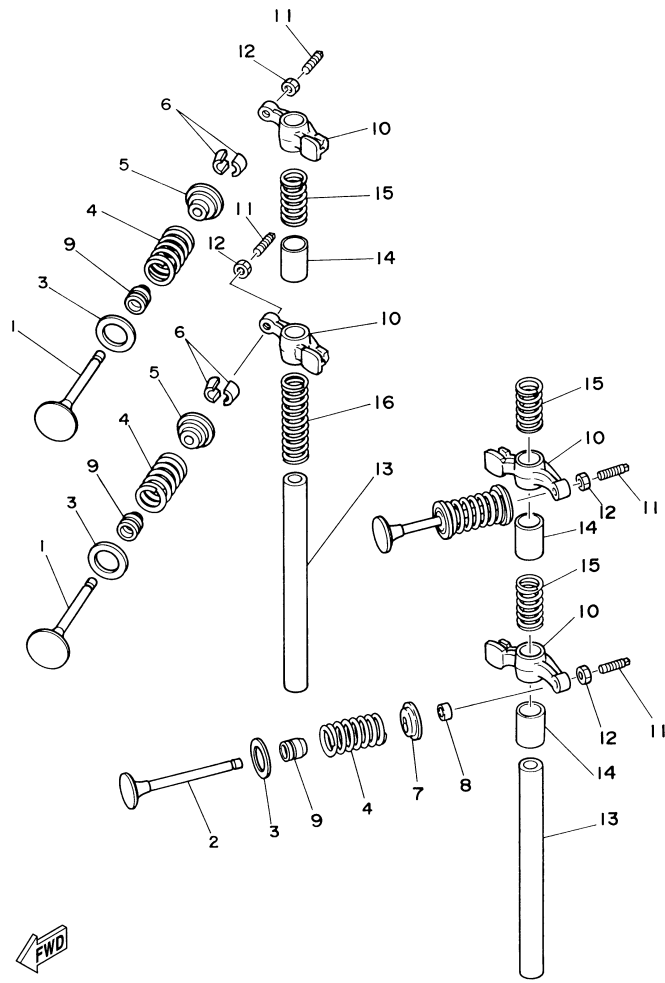



6G90010-4040

Part List

F9.9MLHB 2003 / VALVE

REF - NO	PART NUMBER	PART NAME	QUANTITY	REMARKS
1	6G8-12111-00-00	VALVE, INTAKE	2	
2	6G8-12121-01-00	VALVE, EXHAUST	2	
3	6G8-12116-00-00	SEAT, VALVE SPRING	4	
4	6G8-12113-00-00	SPRING, VALVE INNER	4	
5	6G8-12117-00-00	RETAINER, VALVE SPRING	2	
6	30X-12118-00-00	LOCK, VALVE SPRING RETAINER	4	
7	6G8-12117-10-00	RETAINER, VALVE SPRING	2	
8	6G8-12153-00-00	LIFTER, VALVE	2	
9	51Y-12119-00-00	SEAL, VALVE STEM	4	
10	6G8-12151-00-00	ARM, VALVE ROCKER	4	
11	6G8-12159-00-00	SCREW, VALVE ADJUSTING	4	
12	6G8-12158-00-00	NUT, LOCK	4	
13	6G8-12146-00-00	SHAFT, ROCKER	2	
14	90387-13M56-00	COLLAR	3	
15	90501-12M40-00	SPRING, COMPRESSION	3	
16	90501-12M41-00	SPRING, COMPRESSION	1	

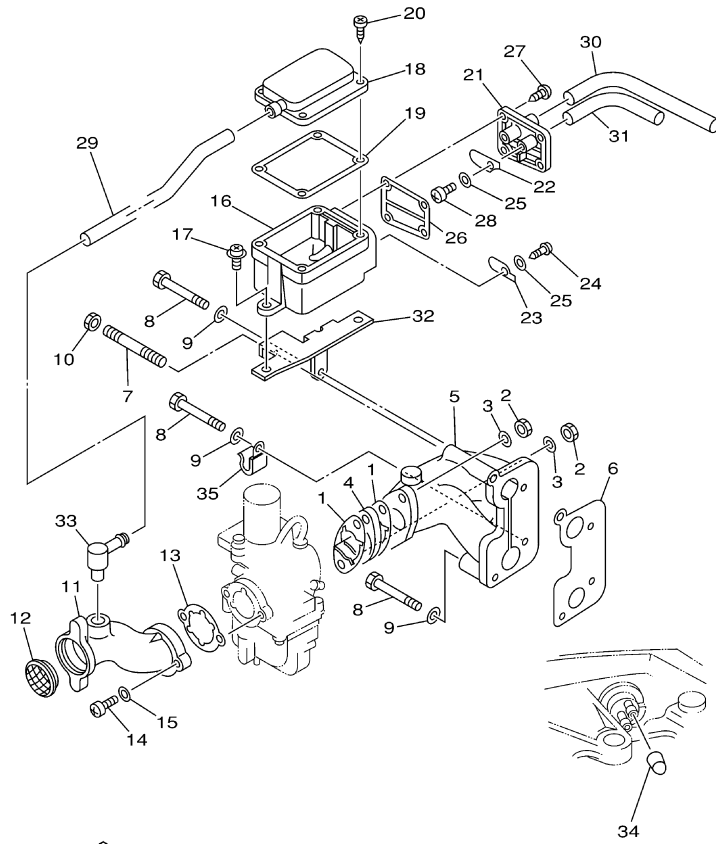
F9.9MLHB 2003 / INTAKE



6G91100-2050

Part List

F9.9MLHB 2003 / INTAKE

REF - NO	PART NUMBER	PART NAME	QUANTITY	REMARKS
1	6G8-13646-A0-00	GASKET, MANIFOLD 2	2	
2	95380-06700-00	NUT	2	
3	92990-06600-00	WASHER, PLATE	2	
4	6G8-13647-00-00	GASKET, MANIFOLD 3	1	
5	6G8-13641-01-94	MANIFOLD 1	1	
6	6G8-13645-00-00	GASKET, MANIFOLD 1	1	
7	90116-06M15-00	BOLT, STUD	1	
8	97095-06045-00	.BOLT	3	
9	92995-06600-00	WASHER	3	
10	95380-06700-00	NUT	1	
11	6G8-14479-10-94	FUNNEL	1	
12	6G8-14478-00-00	LOUVER	1	
13	6G8-14198-A0-00	.GASKET	1	
14	97880-05016-00	SCREW, PAN HEAD	2	
15	92990-05600-00	WASHER, PLATE	2	
16	6G8-15358-00-00	SEPARATOR, OIL	1	
17	90159-06M05-00	SCREW, WITH WASHER	2	
18	6G8-15368-00-94	SEPERATOR, OIL	1	
19	6G8-15369-00-00	GASKET, OIL SEAL HOUSING	1	
20	97780-40512-00	SCREW, TAPPING	4	
21	6G8-15371-00-94	BREATHER	1	
22	6G8-15346-00-00	BREATHER 1	1	
23	6G8-15347-00-00	BREATHER 2	1	
24	97780-40512-00	SCREW, TAPPING	1	
25	92990-04200-00	WASHER	2	
26	6G8-15374-00-00	GASKET, BREATHER	1	
27	97780-40512-00	SCREW, TAPPING	4	
28	98507-04010-00	SCREW, PAN HEAD	1	
29	6G8-15393-10-00	PIPE, BREATHER 2	1	
30	90445-11M52-00	HOSE (L150)	1	
31	90445-09065-00	HOSE (L90)	1	
32	6G8-15376-00-00	HOLDER, GUIDE	1	
33	6G8-15373-01-00	PIPE, BREATHER	1	
34	6G8-13448-00-00	CAP	1	
35	90465-06M86-00	.CLAMP	1	

Part Notes

F9.9MLHB 2003 / INTAKE

PART NUMBER	NOTE TEXT
92990-06600-00 	OEM: This part number is among the Top 100 Most Popular Marine Maintenance Parts as of March 2014.

©2014 Yamaha Motor Corporation, U.S.A. All rights reserved.

F9.9MLHB 2003 / CARBURETOR

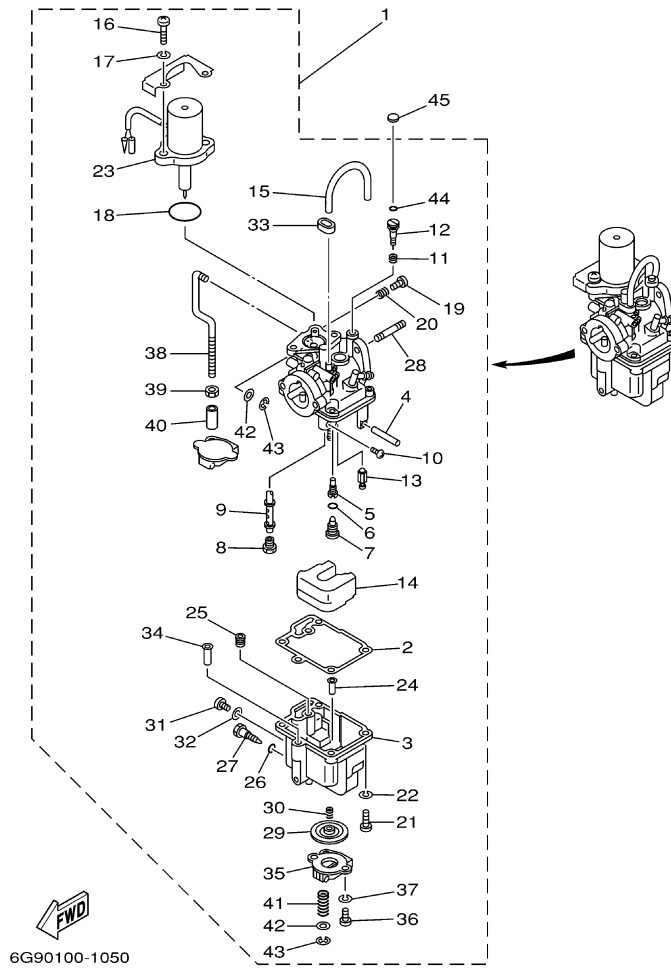

6G90100-1050

Part List

F9.9MLHB 2003 / CARBURETOR

REF - NO	PART NUMBER	PART NAME	QUANTITY	REMARKS
1	6G9-14301-21-00	CARBURETOR ASSY 1	1	
2	6G8-14384-01-00	.GASKET, FLOAT CHAMBER	1	
3	6G8-14381-02-00	.BODY, FLOAT CHAMBER	1	
4	647-14386-00-00	.PIN, FLOAT	1	
5	6G8-14342-24-00	.JET, PILOT (#48)	1	
6	654-14198-00-00	.GASKET	1	
7	6G8-14345-00-00	.PLUG, MAIN NOZZLE	1	
8	648-14343-43-00	.JET, MAIN (#86)	1	
9	6G8-14341-20-00	.NOZZLE, MAIN	1	
10	6G8-14216-00-00	.SCREW	1	
11	647-14334-00-00	.SPRING	1	
12	6G8-14323-20-00	.SCREW, AIR ADJUSTING	1	
13	6G8-14392-00-00	.VALVE, NEEDLE	1	
14	6G8-14385-00-00	.FLOAT	1	
15	6G8-14197-01-00	.PIPE	1	
16	97880-06018-00	.SCREW, PAN HEAD	2	
17	92990-06100-00	.WASHER, SPRING	2	
18	1HV-14147-00-00	.O-RING	1	
19	664-14321-01-00	.SCREW, THROTTLE	1	
20	646-14212-00-00	.SPRING, PILOT ADJUSTING	1	
21	98580-04016-00	.SCREW, PAN HEAD	4	
22	92990-04100-00	.WASHER, SPRING	4	
23	6G8-1410A-01-00	.STARTER SET	1	
24	6G8-14827-00-00	.FILTER	1	
25	6A4-14344-30-00	.JET, STARTER (#60)	1	
26	5Y1-14397-00-00	.O-RING	1	
27	6G8-14383-00-00	.SCREW, DRAIN	1	
28	90116-06M26-00	.BOLT, STUD	2	
29	6G8-14368-02-00	.DIAPHRAGM ASSEMBLY	1	
30	6G8-14275-01-00	.SPRING	1	
31	97890-05006-00	.SCREW, PAN HEAD	1	
32	646-14198-01-00	.GASKET	1	
33	6G8-14349-00-00	.PIPE	1	
34	6G8-14217-00-00	.VALVE, CHOKE	1	
35	6G8-14293-03-00	.COVER 1	1	
36	98580-04010-00	.SCREW, PAN HEAD	2	
37	92990-04100-00	.WASHER, SPRING	2	
38	6G8-14379-00-00	.ROD, STARTER	1	
39	98813-03100-00	.NUT	1	
40	6G8-14229-00-00	.SHAFT, CHOKE	1	
41	6G8-14286-01-00	.SPRING	1	
42	6G8-14357-00-00	.WASHER, PLAIN	2	
43	389-14137-00-00	.CLIP	2	
44	5H0-14397-00-00	.O-RING	1	
45	6G8-1432A-10-00	PLUG	1	

F9.9MLHB 2003 / OIL PUMP

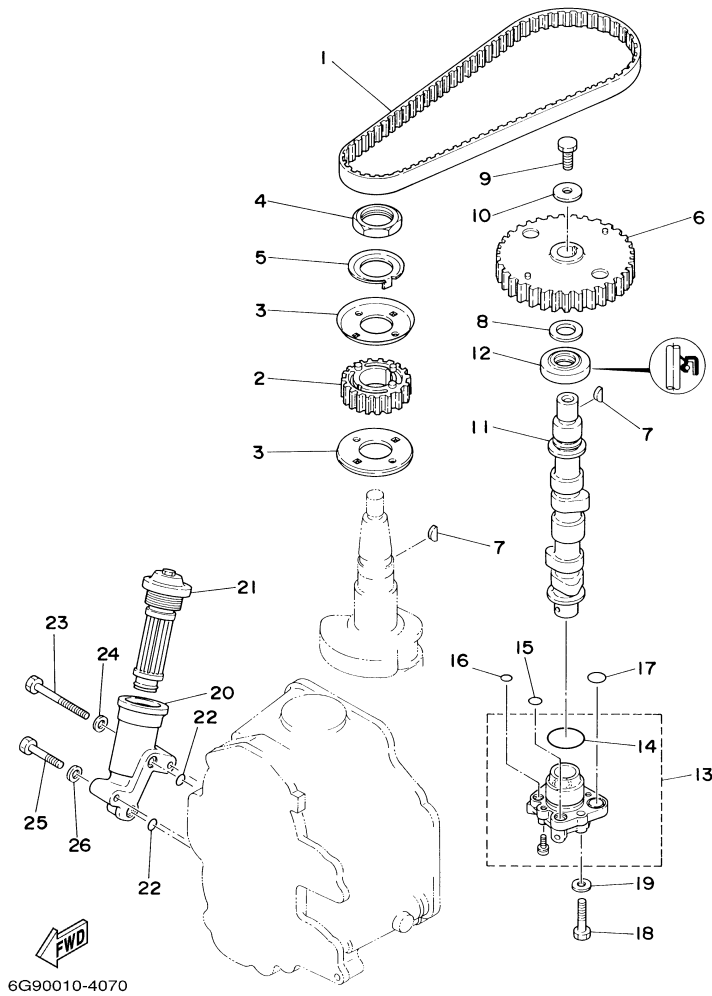

©2014 Yamaha Motor Corporation, U.S.A. All rights reserved.

Part List

F9.9MLHB 2003 / OIL PUMP

REF - NO	PART NUMBER	PART NAME	QUANTITY	REMARKS
1	6G8-46241-00-00	V-BELT	1	
2	6G8-11536-00-94	GEAR, DRIVE	1	
3	6G8-11557-00-00	WASHER 1	2	
4	90170-24M09-00	NUT	1	
5	6G8-11587-01-00	WASHER, LOCK	1	
6	6G8-11537-00-94	GEAR, DRIVEN	1	
7	90280-03M01-00	.KEY, WOODRUFF	2	
8	90201-13201-00	WASHER, PLATE	1	
9	97013-06016-00	BOLT	1	
10	90201-06M94-00	WASHER, PLATE	1	
11	6G8-12171-00-00	CAMSHAFT 1	1	
12	93102-18M21-00	.OIL SEAL	1	
13	6G8-13300-02-00	OIL PUMP ASSY	1	
14	93210-27ME3-00	.O-RING	1	
15	93210-10M61-00	.O-RING	1	
16	93210-09M01-00	.O-RING	1	
17	93210-13M63-00	.O-RING	2	
18	97095-06025-00	BOLT	3	
19	92995-06600-00	WASHER	3	
20	6G8-13442-00-1S	HOUSING, OIL FILTER	1	
21	6G8-13440-00-00	ELEMENT ASSY,OIL CLEANER	1	
22	93210-09M01-00	.O-RING	2	
23	97013-06050-00	BOLT	1	
24	92903-06600-00	WASHER, PLATE	1	
25	97013-06030-00	BOLT	1	
26	92903-06600-00	WASHER, PLATE	1	

F9.9MLHB 2003 / FUEL 1

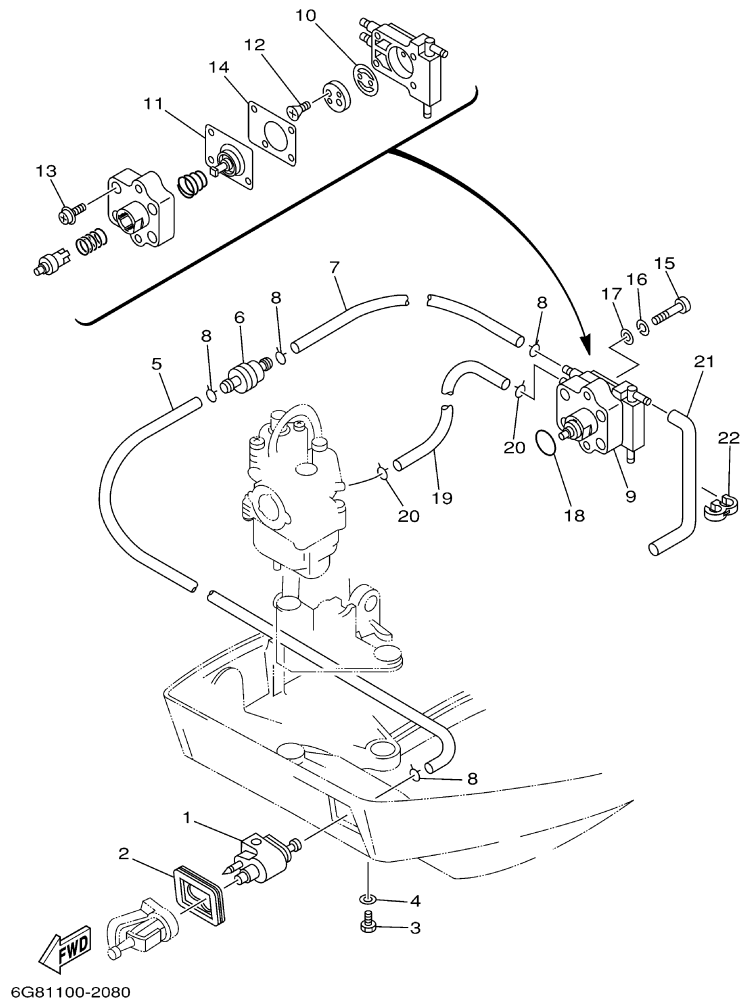

©2014 Yamaha Motor Corporation, U.S.A. All rights reserved.



Part List

F9.9MLHB 2003 / FUEL 1

REF - NO	PART NUMBER	PART NAME	QUANTITY	REMARKS
1	6G1-24304-02-00	FUEL PIPE JOINT COMP. 1	1	
2	6G8-24329-00-00	SEAL	1	
3	97095-06020-00	BOLT	1	
4	92995-06600-00	WASHER	1	
5	6G8-24311-00-00	PIPE, FUEL 1	1	
6	646-24251-02-00	.STRAINER 1	1	
7	90445-09065-00	HOSE (L90)	1	
8	90467-08004-00	CLIP	4	
9	6G8-24410-05-00	FUEL PUMP ASSY	1	
10	6G8-24421-10-00	.VALVE, CHECK	1	
11	6G8-24411-02-00	.DIAPHRAGM	1	
12	98780-03008-00	.SCREW, FLAT HEAD	2	
13	97603-04218-00	.SCREW, PAN HEAD WITH WASHER	4	
14	6G8-24471-00-00	.DIAPHRAGM	1	
15	97880-06025-00	SCREW, PAN HEAD	2	
16	92990-06100-00	..WASHER, SPRING	2	
17	92990-06600-00	WASHER, PLATE	2	
18	93210-20M65-00	.O-RING	1	
19	90445-09105-00	HOSE (L300)	1	
20	90467-08004-00	CLIP	2	
21	6J8-24311-00-00	PIPE, FUEL 1	1	
22	90464-09M21-00	CLAMP	1	

Part Notes

F9.9MLHB 2003 / FUEL 1

PART NUMBER	NOTE TEXT
646-24251-02-00 	OEM: This part number is among the Top 100 Most Popular Marine Maintenance Parts as of March 2014.
92990-06600-00 	OEM: This part number is among the Top 100 Most Popular Marine Maintenance Parts as of March 2014.

©2014 Yamaha Motor Corporation, U.S.A. All rights reserved.

F9.9MLHB 2003 / FUEL 2

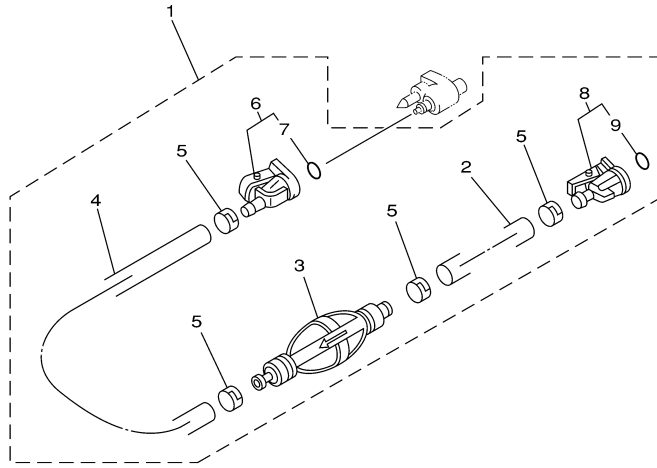

6960100-0050

Part List

F9.9MLHB 2003 / FUEL 2

REF - NO	PART NUMBER	PART NAME	QUANTITY	REMARKS
1	6Y1-24306-53-00	FUEL PIPE COMP. 1	1	AP
2	90445-11M06-00	.HOSE (L2050)	1	
3	6Y1-24360-52-00	.PRIMER PUMP ASSY	1	
4	90445-11M05-00	.HOSE (L850)	1	
5	650-24351-51-00	.BAND 1	4	
6	6G1-24305-03-00	.FUEL PIPE JOINT COMP 2	1	
7	93210-08287-00	..O-RING	1	
8	6Y1-24305-04-00	.FUEL PIPE JOINT COMP 2	1	
9	93210-08287-00	..O-RING	1	

F9.9MLHB 2003 / STARTER MH

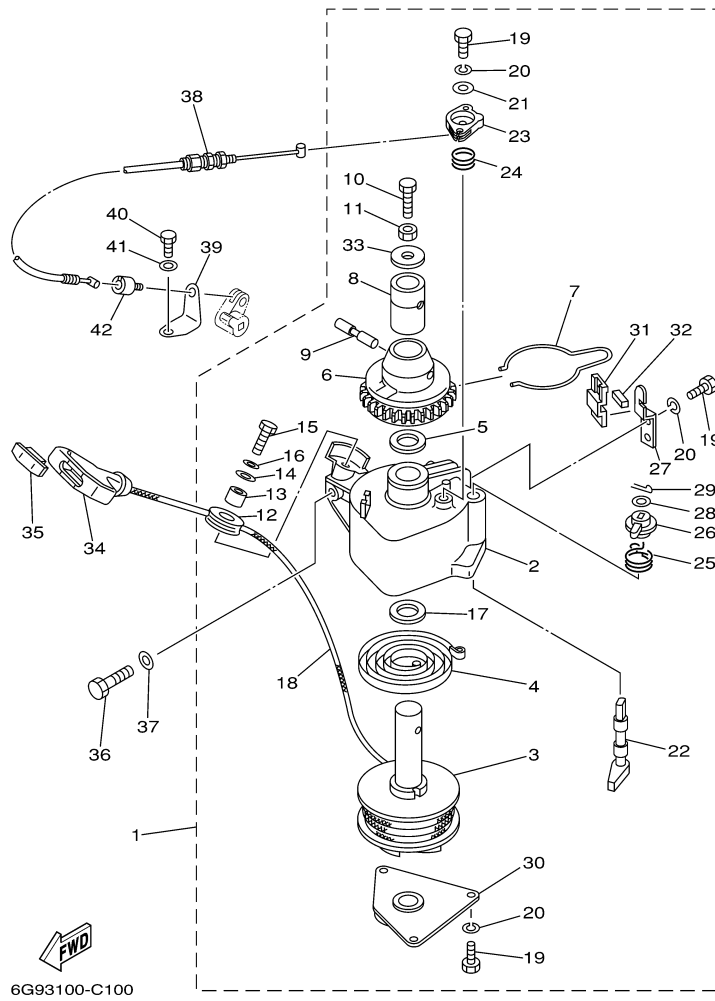

©2014 Yamaha Motor Corporation, U.S.A. All rights reserved.

Part List

F9.9MLHB 2003 / STARTER MH

REF - NO	PART NUMBER	PART NAME	QUANTITY	REMARKS
1	6G8-15710-10-00	STARTER ASSY	1	
2	6G8-15711-00-00	.CASE, STARTER	1	
3	6G8-15714-00-00	.DRUM, SHEAVE	1	
4	6G8-15713-00-00	.SPRING, STARTER	1	
5	6G8-15719-00-00	.WASHER, THRUST	1	
6	6G8-15723-00-00	.PULLEY, STARTER	1	
7	6G8-15715-00-00	.SPRING, FRICTION	1	
8	6G8-15754-00-00	.BUSH 2	1	
9	6G8-15727-00-00	.PIN	1	
10	6G8-15768-00-00	.BOLT	1	
11	95303-08700-00	.NUT	1	
12	6F5-15752-00-00	.ROLLER, WIRE	1	
13	663-15753-00-00	.BUSH	1	
14	663-15791-00-00	.WASHER, LOCK	1	
15	97395-06025-00	.BOLT	1	
16	92995-06100-00	.WASHER, SPRING	1	
17	6G8-15739-00-00	.WASHER, THRUST	1	
18	90890-44373-00	ROPE, STARTER	1	UNAVAILABLE - OBTAIN LOCALLY - CUT TO 1.8M LENGTH
19	97395-05012-00	.BOLT	6	
20	92995-05100-00	.WASHER	6	
21	6G8-15726-00-00	.WASHER, FLAT	1	
22	6G8-15794-00-00	.STOPPER	1	
23	6G8-15746-00-00	.ARM	1	
24	6G8-15767-00-00	.SPRING	1	
25	6G8-15734-00-00	.SPRING, RETURN	1	
26	6G8-15747-00-00	.LINK	1	
27	6G8-15716-00-00	.PLATE, DRIVE	1	
28	92902-06200-00	.WASHER	1	
29	91490-16012-00	.PIN, COTTER	1	
30	6G8-15712-00-00	.COVER, STARTER CASE	1	
31	6G8-15779-00-00	.COVER	1	
32	6G8-15789-00-00	.DAMPER	1	
33	6G8-15742-00-00	.WASHER, DRIVE PAWL	1	
34	6G1-15755-00-00	.HANDLE, STARTER	1	
35	689-15779-01-00	COVER	1	
36	97075-08030-00	BOLT	3	
37	92995-08600-00	WASHER	3	
38	6G8-15770-00-00	CABLE COMP., STARTER STOP	1	
39	6G8-15771-00-00	STAY 1	1	
40	97095-06012-00	BOLT	1	
41	92995-06600-00	WASHER	1	
42	6G8-15772-00-00	STAY 2	1	

F9.9MLHB 2003 / GENERATOR

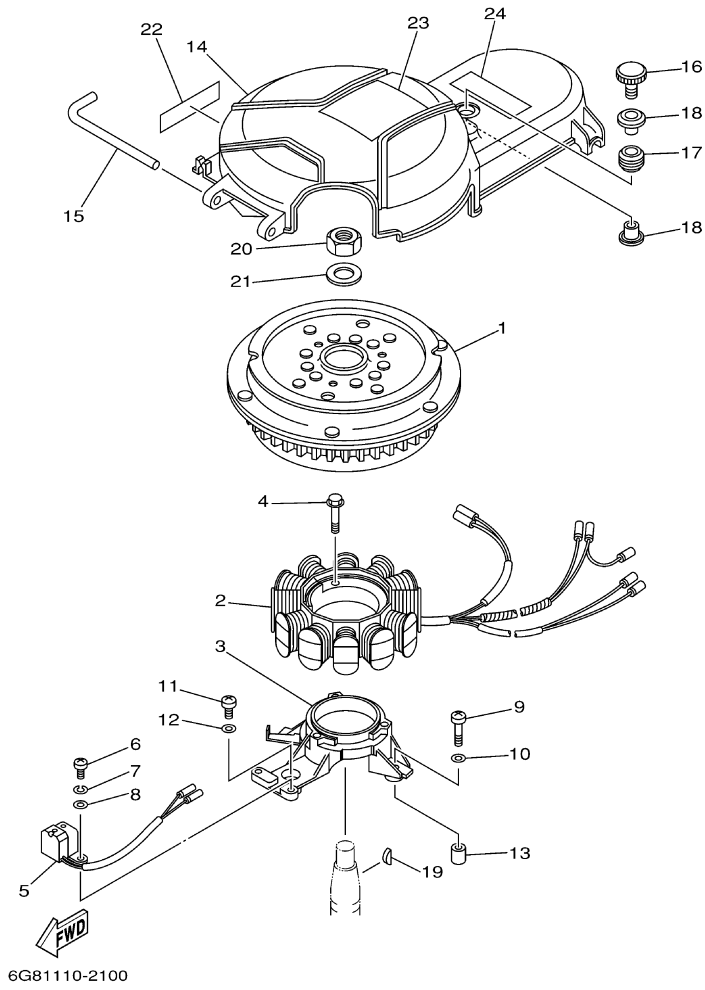

©2014 Yamaha Motor Corporation, U.S.A. All rights reserved.



Part List

F9.9MLHB 2003 / GENERATOR

REF - NO	PART NUMBER	PART NAME	QUANTITY	REMARKS
1	6G8-85550-01-00	ROTOR ASSY	1	UR ER
1	6G8-85550-11-00	ROTOR ASSY	1	UR MH
2	6G9-85510-01-00	STATOR ASSY	1	
3	6G8-85561-00-94	BASE, MAGNETO	1	
4	95023-06025-00	BOLT	3	
5	6G8-85580-02-00	COIL, PULSER	1	
6	97880-05012-00	SCREW, PAN HEAD	2	
7	92990-05100-00	.WASHER, SPRING	2	
8	92990-05600-00	WASHER, PLATE	2	
9	97880-06025-00	SCREW, PAN HEAD	2	
10	92990-06600-00	WASHER, PLATE	2	
11	97880-06020-00	SCREW, PAN HEAD	1	
12	92990-06600-00	WASHER, PLATE	1	
13	99530-08012-00	PIN, DOWEL	2	
14	6G8-81337-01-00	COVER, FLYWHEEL	1	
15	6G8-42752-00-00	SHAFT	1	
16	6G8-81323-00-00	SCREW 1	1	
17	90480-15M31-00	GROMMET	1	
18	90387-06M71-00	COLLAR	2	
19	90280-05013-00	KEY, WOODRUFF	1	
20	90170-12066-00	NUT	1	
21	90201-12472-00	WASHER, PLATE	1	
22	6G8-13437-44-00	MARK, CAUTION	1	
23	6G8-14427-41-00	LABEL, INSTRUCTION	1	
24	6A1-83625-41-00	MARK 5	1	

Part Notes

F9.9MLHB 2003 / GENERATOR

PART NUMBER	NOTE TEXT
92990-06600-00 	OEM: This part number is among the Top 100 Most Popular Marine Maintenance Parts as of March 2014.
92990-06600-00 	OEM: This part number is among the Top 100 Most Popular Marine Maintenance Parts as of March 2014.

©2014 Yamaha Motor Corporation, U.S.A. All rights reserved.

F9.9MLHB 2003 / ELECTRICAL 1

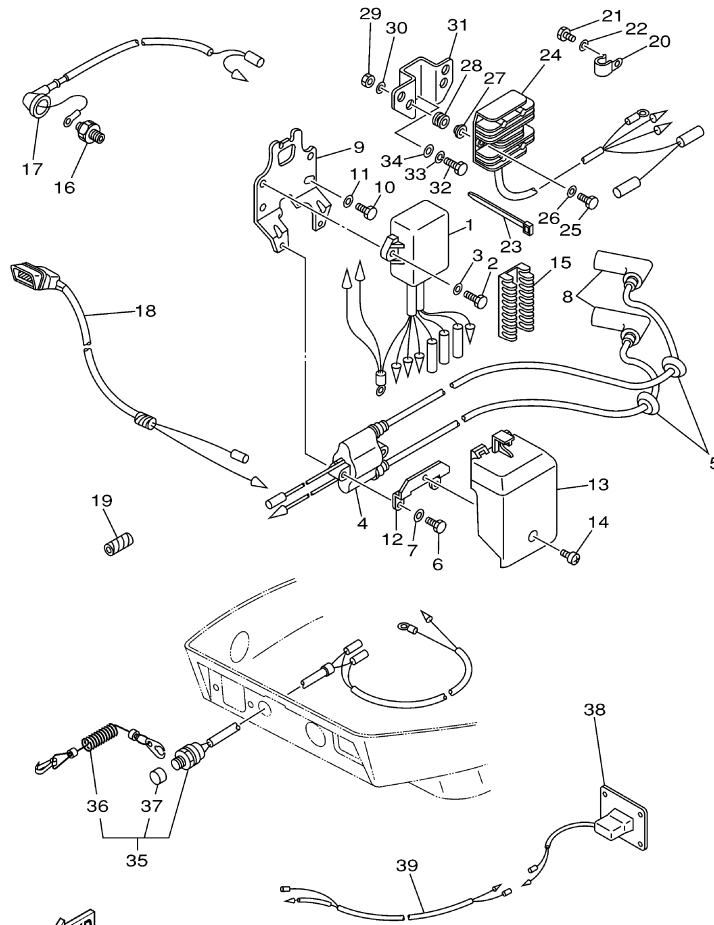

6G90110-9120



Part List

F9.9MLHB 2003 / ELECTRICAL 1

REF - NO	PART NUMBER	PART NAME	QUANTITY	REMARKS
1	6G9-85540-22-00	C.D.I. UNIT ASSY	1	
2	97095-06020-00	BOLT	2	
3	92995-06600-00	WASHER	2	
4	6G8-85570-21-00	IGNITION COIL ASSY	1	
5	90480-25161-00	GROMMET	2	
6	97095-06025-00	BOLT	2	
7	92995-06600-00	WASHER	2	
8	6G8-82370-30-00	PLUG CAP ASSY	2	
9	6G8-85542-00-00	BRACKET	1	
10	97095-06020-00	BOLT	2	
11	92995-06600-00	WASHER	2	
12	6G8-85525-00-00	PLATE	1	
13	6G8-81916-00-00	COVER, TERMINAL	1	
14	98980-06008-00	SCREW, BIND	1	
15	6G8-82522-00-00	CLAMP, COUPLER	1	
16	6G8-82504-00-00	OIL PRESSURE SWITCH ASSY	1	
17	6G8-82127-00-00	WIRE, LEAD 2	1	
18	6G8-83582-01-00	PILOT LIGHT ASSY	1	MH
19	90446-10M02-00	HOSE	1	
20	90465-06M86-00	.CLAMP	1	
21	97013-06012-00	BOLT	1	
22	92903-06600-00	WASHER, PLATE	1	
23	90465-13M11-00	CLAMP	1	
24	6G8-81960-A1-00	RECTIFIER ASSY	1	ER
25	97095-06025-00	BOLT	2	ER
26	92995-06600-00	WASHER	2	ER
27	90387-06M70-00	COLLAR	2	ER
28	90480-13M24-00	GROMMET	2	ER
29	95380-06700-00	NUT	2	ER
30	92990-06600-00	WASHER, PLATE	2	ER
31	6G8-81948-02-00	BRACKET	1	ER
32	97095-06020-00	BOLT	1	ER
33	92995-06100-00	WASHER, SPRING	1	ER
34	92995-06600-00	WASHER	1	ER
35	6G9-82575-02-00	ENGINE STOP SWITCH ASSY	1	MH
36	682-82556-00-00	.LANYARD, STOP SWITCH	1	FOR 6G9-82575-02
37	689-8257Y-00-00	.CAP	1	FOR 6G9-82575-02
38	6G8-83530-00-00	PILOT LIGHT ASSY	1	ER
39	6G8-82541-00-00	WIRE, LEAD	1	ER

Part Notes

F9.9MLHB 2003 / ELECTRICAL 1

PART NUMBER	NOTE TEXT
92990-06600-00 	OEM: This part number is among the Top 100 Most Popular Marine Maintenance Parts as of March 2014.
682-82556-00-00 	OEM: This part number is among the Top 100 Most Popular Marine Maintenance Parts as of March 2014.

©2014 Yamaha Motor Corporation, U.S.A. All rights reserved.

F9.9MLHB 2003 / ELECTRICAL 2

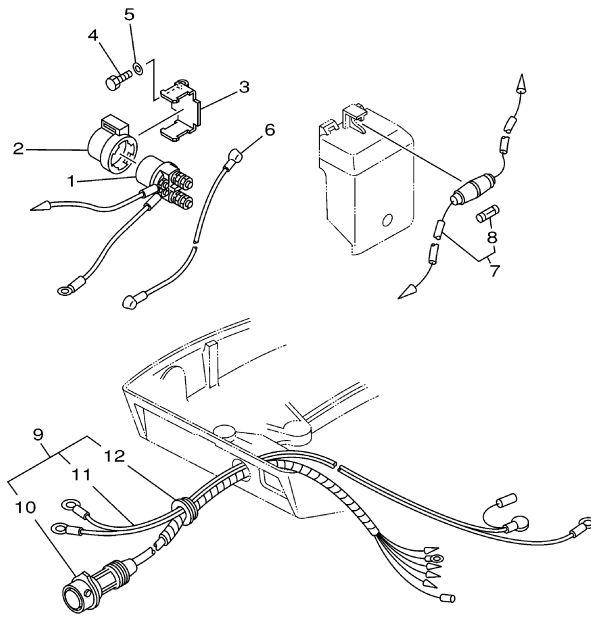

6G90110-9130

Part List

F9.9MLHB 2003 / ELECTRICAL 2

REF - NO	PART NUMBER	PART NAME	QUANTITY	REMARKS
1	6J0-81941-10-00	STARTER RELY ASSY	1	ER
2	6G1-81952-00-00	HOLDER, RELAY	1	ER
3	6G8-81953-00-00	STAY, RELAY	1	ER
4	97095-06012-00	BOLT	1	ER
5	92995-06600-00	WASHER	1	ER
6	6G8-82117-00-00	WIRE, LEAD	1	ER
7	6G8-82150-00-00	FUSE HOLDER ASSY	1	ER
8	663-82151-00-00	.FUSE (12V-20A)	1	
9	6G8-82580-00-00	WIRE HARNESS ASSY 2	1	ER
10	6G8-82590-00-00	.WIRE HARNESS ASSY	1	
11	6G8-82105-01-00	.BATTERY CABLE	1	
12	6G8-42724-50-00	.GROMMET	1	

F9.9MLHB 2003 / STARTING MOTOR

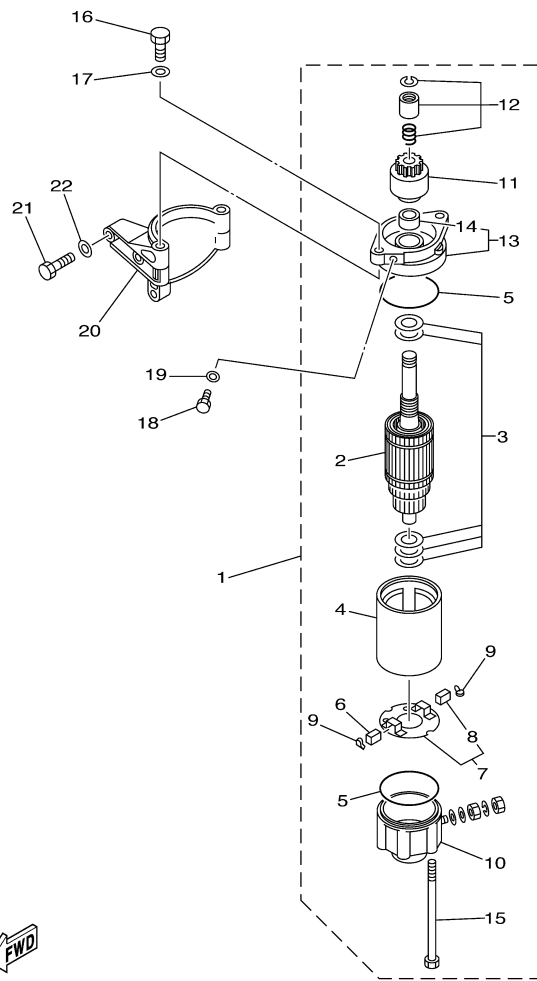



6G80100-8140

Part List

F9.9MLHB 2003 / STARTING MOTOR

REF - NO	PART NUMBER	PART NAME	QUANTITY	REMARKS
1	6G8-81800-11-00	STARTING MOTOR ASSY	1	ER
2	689-81850-12-00	.ARMATURE ASSY	1	
3	689-81809-11-00	.WASHER KIT	1	
4	689-81810-11-00	.STATOR ASSY	1	
5	689-81847-11-00	.O-RING	2	
6	689-81811-11-00	.BRUSH 1	1	
7	689-81840-11-00	.BRUSH HOLDER ASSY	1	
8	689-81812-11-00	..BRUSH 2	1	
9	689-81813-10-00	.SPRING, BRUSH	2	
10	689-81820-11-00	.REAR BRACKET ASSY	1	
11	689-81807-12-00	.GEAR ASSY, STARTING MOTOR	1	
12	689-81857-11-00	.PINION STOPPER SET	1	
13	6F5-81830-11-00	.FRONT BRACKET ASSY	1	
14	689-81831-00-00	..METAL, FRONT	1	
15	689-81826-10-00	.BOLT	2	
16	97075-08025-00	BOLT	2	ER
17	92995-08600-00	WASHER	2	ER
18	97095-08016-00	BOLT	1	ER
19	92995-08600-00	WASHER	1	ER
20	6G8-81822-40-94	BRACKET, STARTING MOTOR	1	ER
21	97013-08030-00	BOLT	3	ER
22	92903-08600-00	WASHER, PLATE	3	ER

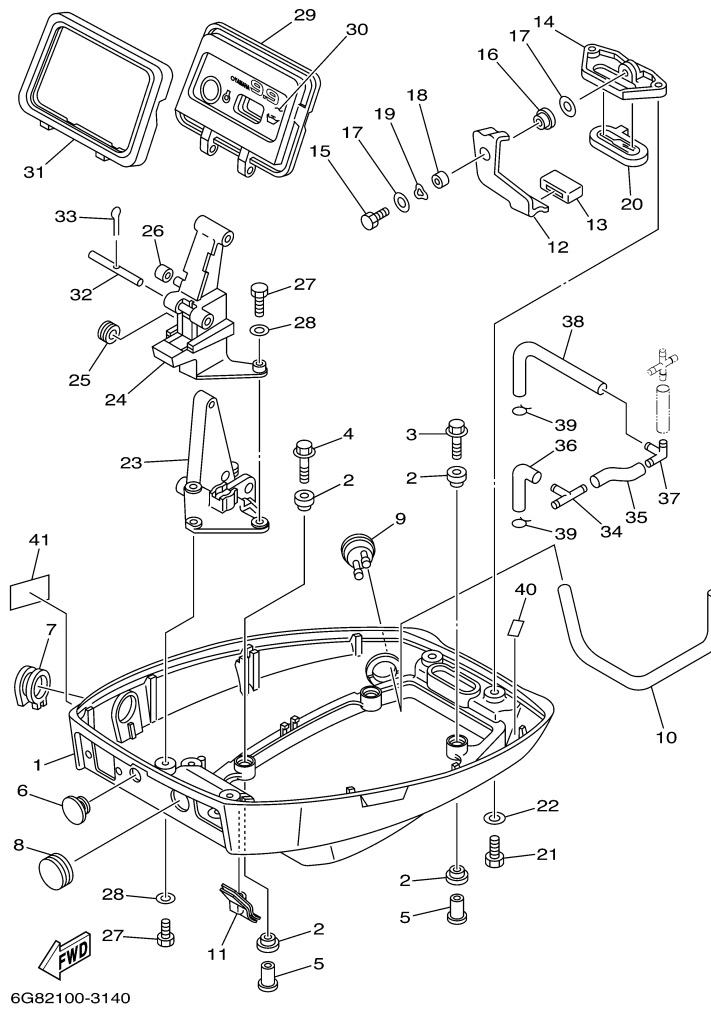
F9.9MLHB 2003 / BOTTOM COWLING



©2014 Yamaha Motor Corporation, U.S.A. All rights reserved.

Part List

F9.9MLHB 2003 / BOTTOM COWLING

REF - NO	PART NUMBER	PART NAME	QUANTITY	REMARKS
1	6G8-42711-02-4D	COWLING, BOTTOM 1	1	
2	90480-09M35-00	GROMMET	8	
3	90119-06M56-00	BOLT, WITH WASHER	2	
4	90119-06M55-00	BOLT, WITH WASHER	2	
5	90387-06M15-00	COLLAR	4	
6	90480-17165-00	GROMMET	1	ER
7	6G9-42724-00-00	GROMMET	1	UR MH
7	6G8-42724-00-00	GROMMET	1	UR ER
8	6G8-42725-10-00	GROMMET	1	MH
9	6G8-44391-00-00	NIPPLE, HOSE	1	
10	90445-09M00-00	HOSE (L180)	1	
11	6G8-42727-00-00	GROMMET	1	
12	6G8-42815-00-00	LEVER, CLAMP	1	
13	6G8-42831-00-00	BUSHING	1	
14	6G8-42811-00-94	STAY	1	
15	97013-06016-00	BOLT	1	
16	90386-08M49-00	BUSH	1	
17	90201-06M31-00	.WASHER, PLATE	2	
18	90387-06M72-00	COLLAR	1	
19	90206-08M13-00	WASHER, WAVE	1	
20	6G8-42748-00-00	GROMMET	1	
21	97095-06016-00	BOLT	2	
22	92995-06600-00	WASHER	2	
23	6G8-42738-00-94	PLATE, FITTING	1	
24	6G8-42719-00-94	PANEL, FRONT LOWER	1	
25	90480-19031-00	GROMMET	1	
26	90445-05ME6-00	HOSE (L8)	1	
27	97095-06016-00	BOLT	4	
28	92995-06600-00	WASHER	4	
29	6G8-42614-12-00	PANEL, FRONT UPPER	1	UR ER
29	6G8-42614-02-00	PANEL, FRONT UPPER	1	UR MH
30	6G8-42677-50-00	GRAPHIC, FRONT	1	UR ER
30	6G8-42677-30-00	GRAPHIC, FRONT	1	UR MH
31	6G8-42629-02-00	SEAL	1	
32	6G8-42755-00-00	HINGE, COWLING	1	
33	91490-16010-00	PIN. COTTER	1	
34	6G8-24379-00-00	PIPE, JOINT 4	1	
35	90445-10M78-00	HOSE (L50)	1	
36	6G8-12476-00-00	PIPE 6	1	
37	6G8-24378-01-00	PIPE, JOINT 3	1	
38	6G8-12485-00-00	PIPE 5	1	
39	90467-10M04-00	CLIP	2	
40	6G8-82377-10-00	LABEL	1	
41	6G8-13444-41-00	MARK	1	

F9.9MLHB 2003 / STEERING MH

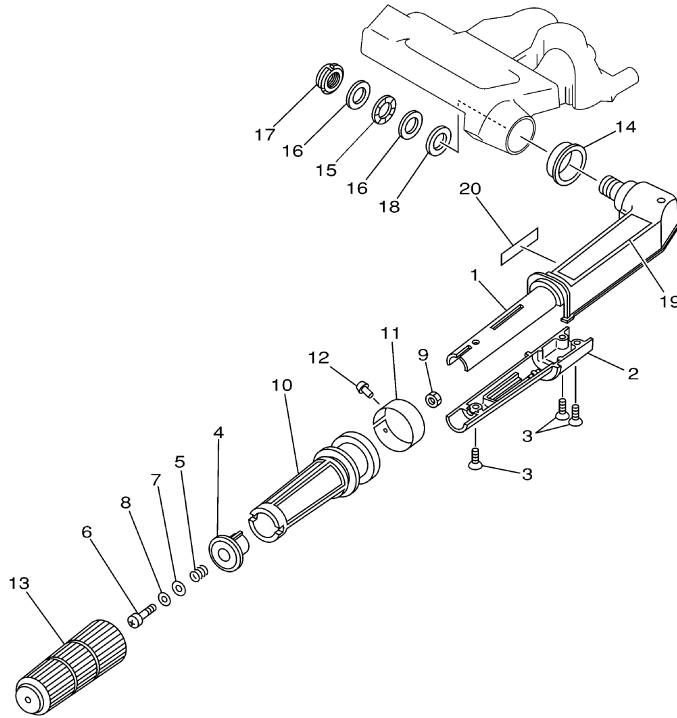

6G91100-2160

Part List

F9.9MLHB 2003 / STEERING MH

REF - NO	PART NUMBER	PART NAME	QUANTITY	REMARKS
1	6G9-42111-03-4D	HANDLE, STEERING	1	
2	6G9-42112-01-4D	HANDLE, STEERING	1	
3	98780-05016-00	.SCREW, FLAT HEAD	3	
4	6G8-42126-01-94	FRICTION, STEERING HANDLE GRIP	1	
5	90501-23M42-00	SPRING, COMPRESSION	1	
6	97880-06030-00	SCREW, PAN HEAD	1	
7	90201-06049-00	WASHER, PLATE	1	
8	90202-06007-00	WASHER, PLATE	1	
9	95380-06700-00	NUT	1	
10	6G8-42119-00-00	GRIP, STEERING HANDLE	1	
11	6G8-42137-01-00	INDICATOR, THROTTLE	1	
12	90269-02M09-00	RIVET	1	
13	6G8-42177-00-00	RUBBER, HANDLE	1	
14	90386-33M56-00	BUSH	1	
15	90206-20M14-00	WASHER, WAVE	1	
16	90201-20M00-00	WASHER, PLATE	2	
17	90185-20M03-00	NUT, SELF-LOCKING	1	
18	90202-20M33-00	WASHER, PLATE	1	
19	6G9-1571Y-40-00	MARK, CAUTION	1	
20	6E0-83627-41-00	LABEL, CAUTION 7	1	

F9.9MLHB 2003 / CONTROL 1 MH

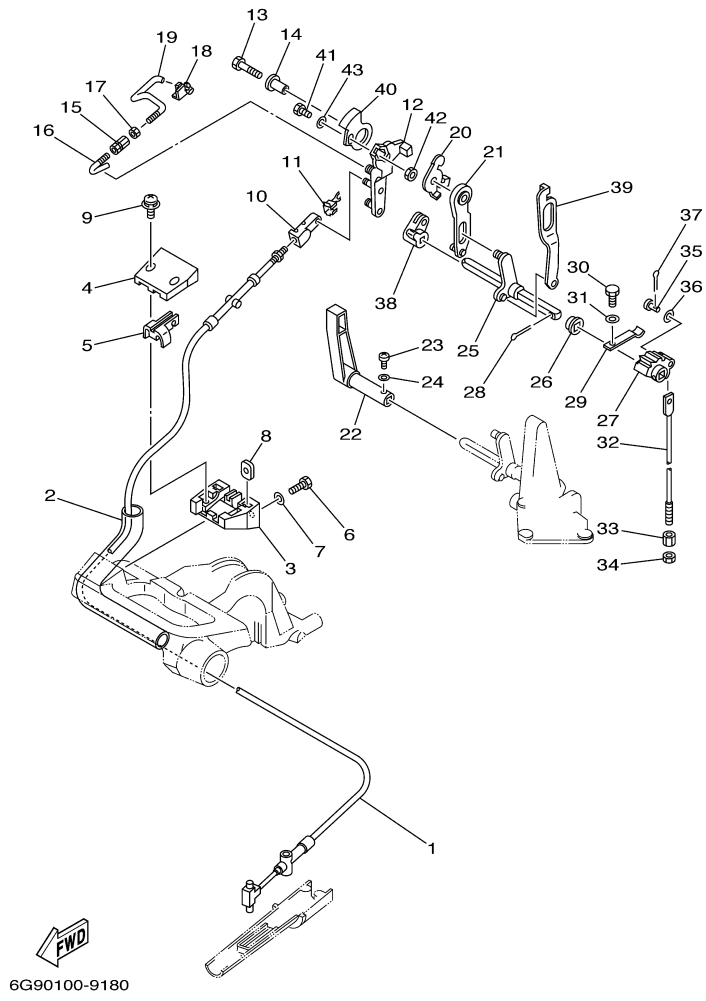

©2014 Yamaha Motor Corporation, U.S.A. All rights reserved.

Part List

F9.9MLHB 2003 / CONTROL 1 MH

REF - NO	PART NUMBER	PART NAME	QUANTITY	REMARKS
1	6G9-48311-02-00	CABLE	1	
2	90445-24M00-00	HOSE (L165)	1	
3	6G8-41661-00-98	BRACKET	1	
4	6G8-41662-00-98	BRACKET	1	
5	6G8-41663-00-00	BRACKET 3	1	
6	97095-06016-00	BOLT	2	
7	92995-06600-00	WASHER	2	
8	6G8-41654-00-00	NUT	2	
9	90159-05M06-00	SCREW, WITH WASHER	2	
10	6G8-26363-00-00	.END, WIRE 1	1	
11	6G8-26364-00-00	.END, CABLE	1	
12	6G8-41212-00-00	ARM, ACCEL.	1	
13	97013-06030-00	BOLT	1	
14	90387-06M58-00	COLLAR	1	
15	6G8-41238-01-00	JOINT, LINK	1	
16	6G8-41241-01-00	ROD, LINK	1	
17	95380-04600-00	.NUT	1	
18	6G8-41237-01-00	JOINT, LINK	1	
19	6G8-41242-01-00	ROD 2	1	
20	6G8-14493-00-00	STAY 1	1	
21	6G8-44111-00-00	HANDLE, GEAR SHIFT	1	
22	6G9-44111-00-98	HANDLE, GEAR SHIFT	1	
23	97880-04016-00	SCREW, PAN HEAD	1	
24	92990-04600-00	WASHER, PLATE	1	
25	6G8-44159-00-00	HANDLE, GEAR SHIFT	1	
26	682-44132-00-00	BUSHING	1	
27	682-44121-01-00	LEVER, SHIFT ROD	1	
28	91490-25020-00	PIN. COTTER	1	
29	682-44116-01-00	SPRING	1	
30	97095-06014-00	BOLT	1	
31	92995-06600-00	WASHER	1	
32	6G9-44143-00-00	ROD, SHIFT	1	UR S
32	6G8-44143-10-00	ROD, SHIFT	1	UR L
33	90170-06015-00	NUT	1	
34	95380-06700-00	NUT	1	
35	91790-05020-00	PIN, CLEVIS	1	
36	92990-05600-00	WASHER, PLATE	1	
37	91490-16010-00	PIN. COTTER	1	
38	6G8-44125-00-00	LEVER, SHIFT ROD	1	
39	6G8-44124-11-00	LINK, SHIFT ROD	1	
40	6G8-41212-11-00	ARM, ACCEL.	1	
41	97013-06014-00	BOLT	1	
42	95380-06600-00	NUT, HEXAGON	1	
43	92990-06600-00	WASHER, PLATE	1	

Part Notes

F9.9MLHB 2003 / CONTROL 1 MH

PART NUMBER	NOTE TEXT
92990-06600-00 	OEM: This part number is among the Top 100 Most Popular Marine Maintenance Parts as of March 2014.

©2014 Yamaha Motor Corporation, U.S.A. All rights reserved.

F9.9MLHB 2003 / CONTROL 2 ER

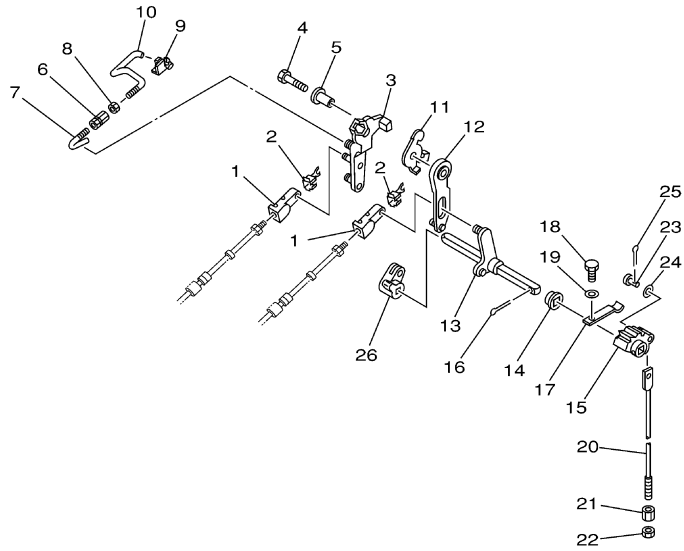

6G90110-9180

Part List

F9.9MLHB 2003 / CONTROL 2 ER

REF - NO	PART NUMBER	PART NAME	QUANTITY	REMARKS
1	6G8-26363-00-00	.END, WIRE 1	2	
2	6G8-26364-00-00	.END, CABLE	2	
3	6G8-41212-00-00	ARM, ACCEL.	1	
4	97013-06030-00	BOLT	1	
5	90387-06M58-00	COLLAR	1	
6	6G8-41238-01-00	JOINT, LINK	1	
7	6G8-41241-01-00	ROD, LINK	1	
8	95380-04600-00	.NUT	1	
9	6G8-41237-01-00	JOINT, LINK	1	
10	6G8-41242-01-00	ROD 2	1	
11	6G8-14493-00-00	STAY 1	1	
12	6G8-44111-00-00	HANDLE, GEAR SHIFT	1	
13	6G8-44159-00-00	HANDLE, GEAR SHIFT	1	
14	682-44132-00-00	BUSHING	1	
15	682-44121-01-00	LEVER, SHIFT ROD	1	
16	91490-25020-00	PIN. COTTER	1	
17	682-44116-01-00	SPRING	1	
18	97095-06014-00	BOLT	1	
19	92995-06600-00	WASHER	1	
20	6G8-44143-10-00	ROD, SHIFT	1	L
21	90170-06015-00	NUT	1	
22	95380-06700-00	NUT	1	
23	91790-05020-00	PIN, CLEVIS	1	
24	92990-05600-00	WASHER, PLATE	1	
25	91490-16010-00	PIN. COTTER	1	
26	6G8-44125-00-00	LEVER, SHIFT ROD	1	

F9.9MLHB 2003 / REMO CON ATTACHMENT

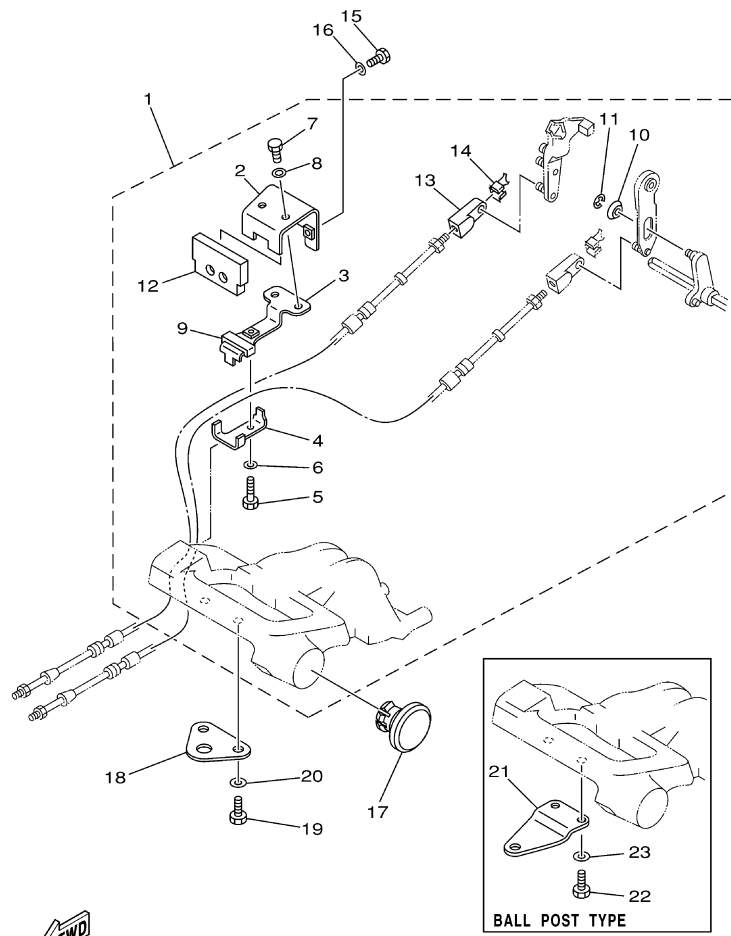



6G80100-9180

Part List

F9.9MLHB 2003 / REMO CON ATTACHMENT

REF - NO	PART NUMBER	PART NAME	QUANTITY	REMARKS
1	6G8-48501-03-00	REMOTE CONT. ATTACHMENT ASSY	1	AP ER
2	6G8-48531-51-00	.BRACKET, REMOTE CONTROL 1	1	
3	6G8-48532-50-00	.BRACKET, REMOTE CONTROL 2	1	
4	6G8-48538-50-00	.CLAMP, CABLE 1	1	
5	97095-06030-00	.BOLT	1	
6	92995-06600-00	.WASHER	1	
7	97095-06012-00	.BOLT	2	
8	92995-06600-00	.WASHER	2	
9	6G8-48565-50-00	.GROMMET	1	
10	90387-06M73-00	.COLLAR	1	
11	93430-04M03-00	.CIRCLIP	1	
12	6G8-48351-51-00	.SEAL RUBBER	1	
13	6G8-26363-00-00	.END, WIRE 1	1	
14	6G8-26364-00-00	.END, CABLE	1	
15	97095-06016-00	BOLT	2	ER
16	92995-06600-00	WASHER	2	ER
17	6G8-42551-00-00	GROMMET	1	ER
18	6G8-48511-20-00	HOOK, STEERING	1	ER STEERING GUIDE TYPE
19	97095-06016-00	BOLT	2	ER
20	92995-06600-00	WASHER	2	ER
21	6G8-48511-10-00	HOOK, STEERING	1	AP ER BALL POST TYPE
22	97095-06016-00	BOLT	2	AP ER
23	92995-06600-00	WASHER	2	AP ER

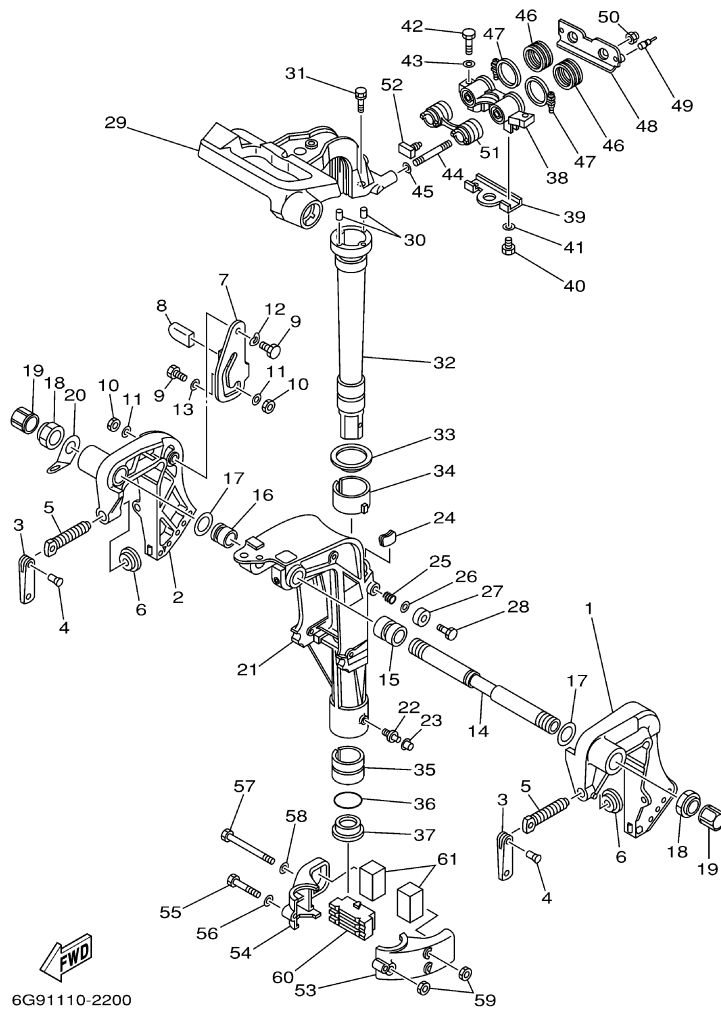
F9.9MLHB 2003 / BRACKET 1



©2014 Yamaha Motor Corporation, U.S.A. All rights reserved.

Part List

F9.9MLHB 2003 / BRACKET 1

REF - NO	PART NUMBER	PART NAME	QUANTITY	REMARKS
1	6G8-43111-04-4D	BRACKET, CLAMP 1	1	
2	6G8-43112-04-4D	BRACKET, CLAMP 2	1	
3	6E0-43118-01-00	HANDLE, TRANSOM CLAMP	2	
4	90243-04M01-00	PIN	2	
5	6E7-43116-00-00	SCREW, TRANSOM CLAMP	2	
6	648-43114-01-00	PAD, TRANSOM CLAMP	2	
7	6G8-43181-00-00	LEVER, TILT STOP	1	
8	682-43318-01-00	COVER	1	
9	90109-06M25-00	BOLT	2	
10	95680-06100-00	NUT, U	2	
11	92990-06600-00	WASHER, PLATE	2	
12	90206-10M15-00	WASHER, WAVE	1	
13	682-43339-01-00	WASHER	1	
14	6G8-43131-00-00	BOLT, CLAMP BRACKET	1	
15	90386-22M92-00	BUSH	1	
16	90386-22M93-00	BUSH	1	
17	90201-22M03-00	WASHER, PLATE	2	
18	90185-22043-00	NUT, SELF-LOCKING	2	
19	6G5-43145-01-00	CAP, CLAMP BRACKET	2	
20	6J8-43113-01-00	PLATE, CLAMP BRACKET	1	
21	6G9-43311-04-4D	BRACKET, SWIVEL 1	1	UR S
21	6G8-43311-15-4D	BRACKET, SWIVEL 1	1	UR L
22	93700-06M03-00	NIPPLE, GREASE	1	
23	663-45119-00-00	CAP, GREASE NIPPLE	1	AP
24	6G8-42528-00-00	PLATE, FRICTION	1	
25	90501-18M00-00	SPRING, COMPRESSION	1	
26	90201-06M31-00	.WASHER, PLATE	1	
27	6G8-43373-00-00	SEAL, DAMPER	1	
28	97095-06025-00	BOLT	1	
29	6G9-42511-01-4D	BRACKET, STEERING	1	
30	93605-15065-00	PIN, DOWEL	2	
31	90119-06M06-00	BOLT, WITH WASHER	2	
32	6G9-42521-00-94	SHAFT, STEERING PIVOT	1	UR S
32	6G8-42521-10-94	SHAFT, STEERING PIVOT	1	UR L
33	90209-45M09-00	WASHER	1	
34	6G8-42537-00-00	BUSHING, PIVOT SHAFT	1	
35	90386-37M47-00	BUSH	1	
36	93210-37M67-00	O-RING	1	
37	90386-37M48-00	BUSH	1	
38	6G8-44517-00-94	MOUNT RUBBER	1	
39	6G8-44526-00-00	PLATE	1	
40	97095-06012-00	BOLT	2	
41	92995-06600-00	WASHER	2	
42	97095-08030-00	BOLT	2	
43	92995-08600-00	WASHER	2	
44	90116-08M28-00	BOLT, STUD	2	
45	90201-08M12-00	.WASHER, PLATE	2	
46	6G8-44522-00-00	SEAL	2	
47	90460-38M06-00	CLAMP, HOSE	2	
48	6G8-44518-00-00	BRACKET COMP.	1	
49	6G8-44533-00-00	DAMPER, UPPER MOUNT RUBBER	2	
50	90185-08057-00	NUT, SELF-LOCKING	2	
51	6G8-44521-00-00	SEAL	1	
52	6G8-44532-00-00	STOPPER, UPPER MOUNT	1	
53	6G8-44551-01-4D	HOUSING, LOWER MOUNT RUBBER	1	
54	6G8-44552-02-4D	HOUSING, LOWER MOUNT RUBBER	1	
55	97095-06045-00	.BOLT	1	
56	92995-06600-00	WASHER	1	

57	97095-06095-00	BOLT	2	
58	92995-06600-00	WASHER	2	
59	95380-06700-00	NUT	3	
60	6G8-44557-00-00	MOUNT DAMPER, LOWER FRONT	1	
61	682-44555-00-00	MOUNT DAMPER, LOWER SIDE	2	

Part Notes

F9.9MLHB 2003 / BRACKET 1

PART NUMBER		NOTE TEXT
92990-06600-00		OEM: This part number is among the Top 100 Most Popular Marine Maintenance Parts as of March 2014.

©2014 Yamaha Motor Corporation, U.S.A. All rights reserved.

F9.9MLHB 2003 / BRACKET 2

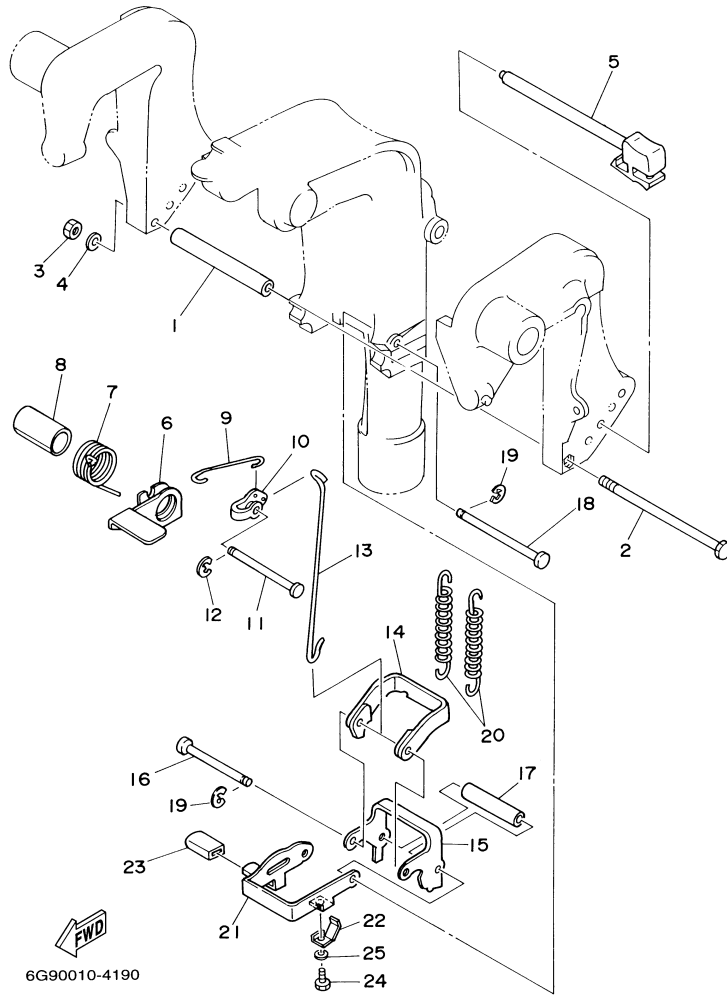

©2014 Yamaha Motor Corporation, U.S.A. All rights reserved.



Part List

F9.9MLHB 2003 / BRACKET 2

REF - NO	PART NUMBER	PART NAME	QUANTITY	REMARKS
1	90387-06M09-00	COLLAR	1	
2	97095-06135-00	BOLT	1	
3	95380-06700-00	NUT	1	
4	92990-06600-00	WASHER, PLATE	1	
5	6G8-43160-01-00	TILT ROD ASSY	1	
6	6G8-43631-03-00	LEVER, TILT	1	
7	90508-18M33-00	SPRING, TORSION	1	
8	90386-20M94-00	BUSH	1	
9	6G8-43616-00-00	ROD, TILT LOCK	1	
10	682-43641-00-00	LEVER, TILT	1	
11	90249-06M20-00	PIN	1	
12	99080-05600-00	CIRCLIP	1	
13	6G8-43617-00-00	ROD, TILT LOCK	1	
14	682-43614-00-00	PLATE, TILT LOCK	1	
15	682-43615-01-00	PLATE, TILT LOCK	1	
16	682-43611-01-00	SHAFT, TILT LOCK	1	
17	90387-06M20-00	COLLAR	1	
18	682-43659-01-00	SHAFT, REVERSE LOCK	1	
19	99080-05600-00	CIRCLIP	2	
20	90506-26M01-00	SPRING, TENSION	2	
21	6G9-43681-00-00	LEVER, SHALLOW WATER DRIVE 1	1	
22	6G9-43643-00-00	SPRING	1	
23	682-43318-01-00	COVER	1	
24	97095-06008-00	BOLT	1	
25	92990-06600-00	WASHER, PLATE	1	

Part Notes

F9.9MLHB 2003 / BRACKET 2

PART NUMBER		NOTE TEXT
92990-06600-00		OEM: This part number is among the Top 100 Most Popular Marine Maintenance Parts as of March 2014.
92990-06600-00		OEM: This part number is among the Top 100 Most Popular Marine Maintenance Parts as of March 2014.

©2014 Yamaha Motor Corporation, U.S.A. All rights reserved.

F9.9MLHB 2003 / UPPER CASING

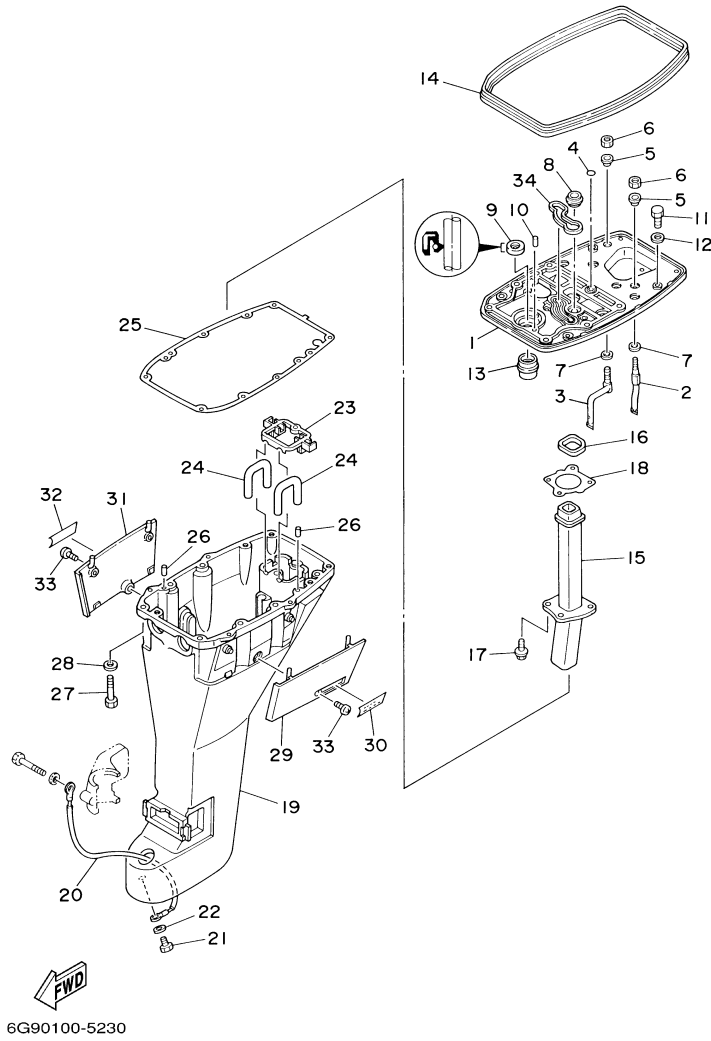

Part List

F9.9MLHB 2003 / UPPER CASING

REF - NO	PART NUMBER	PART NAME	QUANTITY	REMARKS
1	6G8-41137-04-94	GUIDE, EXHAUST	1	
2	6G8-12483-00-00	PIPE 3	1	
3	6G8-12484-00-00	PIPE 4	1	
4	93210-08M60-00	O-RING	1	
5	90386-10M70-00	BUSH	2	
6	95380-10700-00	NUT	2	
7	90202-10M03-00	WASHER, PLATE	2	
8	6G8-44367-00-00	DAMPER, WATER SEAL	1	
9	93101-13M27-00	O-RING	1	
10	93606-12019-00	.PIN, DOWEL	2	
11	97013-06020-00	BOLT	2	
12	92903-06600-00	WASHER, PLATE	2	
13	6G8-45135-00-00	PIPE	1	
14	6G8-42716-00-00	RUBBER, SEAL 1	1	
15	6G8-41131-01-00	MANIFOLD, EXT. 1	1	
16	6G8-41138-00-00	SEAL, EXT. 1	1	
17	90105-06M33-00	BOLT, FLANGE	4	
18	6G8-41133-A0-00	GASKET, EXHAUST MANIFOLD 1	1	
19	6G8-45111-13-4D	CASING, UPPER	1	UR L
19	6G9-45111-03-4D	CASING, UPPER	1	UR S
20	6G8-82149-00-00	WIRE, LEAD 3	1	
21	97095-06012-00	BOLT	1	
22	92995-06600-00	WASHER	1	
23	6G8-45151-10-00	COVER, UPPER CASING	1	
24	6G8-45136-00-00	PIPE	2	
25	6G8-45113-A1-00	.GASKET, UPPER CASING	1	
26	93606-12019-00	.PIN, DOWEL	2	
27	97095-08040-00	BOLT	6	
28	92995-08600-00	WASHER	6	
29	6G8-42741-00-4D	APRON	1	
30	6G8-42791-00-00	MARK 1	1	
31	6G8-42771-00-4D	APRON	1	
32	6G8-42792-00-00	MARK	1	
33	90157-06M04-00	SCREW, PAN HEAD	2	
34	6G8-11355-00-00	SEAL, CYLINDER 1	1	

F9.9MLHB 2003 / OIL PAN

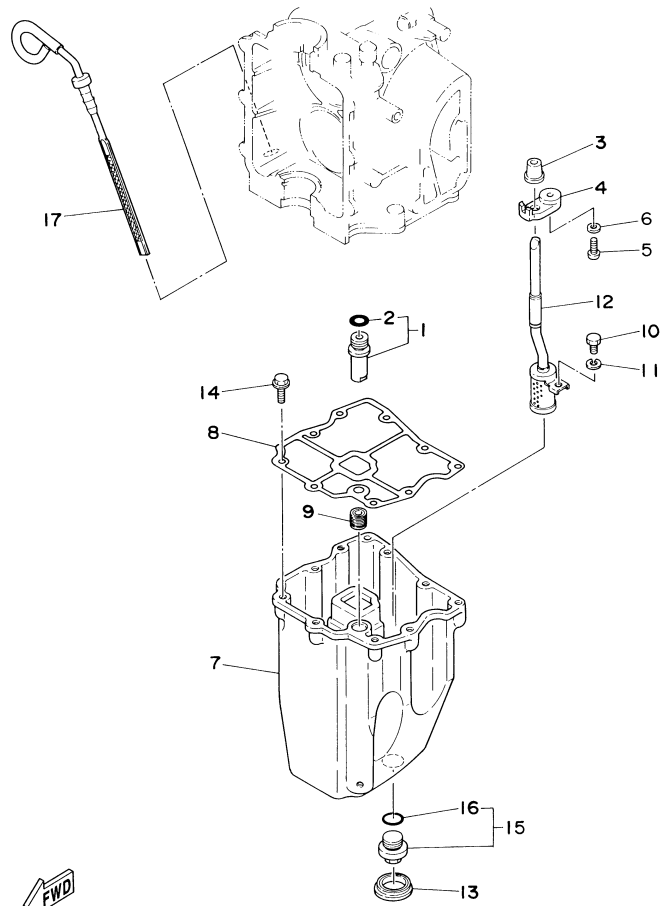



6G90010-4210

Part List

F9.9MLHB 2003 / OIL PAN

REF - NO	PART NUMBER	PART NAME	QUANTITY	REMARKS
1	6G8-11575-00-00	RELIEF VALVE ASSY	1	
2	93210-12M62-00	.O-RING	1	
3	6G8-15379-00-00	SEAL, CRANKCASE	1	
4	6G8-13487-00-00	GUIDE, OIL HOSE	1	
5	97880-05012-00	SCREW, PAN HEAD	1	
6	92990-05600-00	WASHER, PLATE	1	
7	6G8-15311-03-0D	OIL PAN	1	
8	6G8-15312-A1-00	.GASKET, OIL PAN	1	
9	6G8-45127-00-00	SEAL	1	
10	97013-06010-00	BOLT	1	
11	92903-06100-00	WASHER, SPRING	1	
12	6G8-13421-00-00	STRAINER 2	1	
13	6G8-15316-00-00	DAMPER, ENGINE MOUNT 1	1	
14	90105-06M33-00	BOLT, FLANGE	9	
15	6G8-13471-00-00	PLUG, DRAIN	1	
16	93210-16M64-00	.O-RING	1	
17	6G8-15362-04-00	PLUG, OIL LEVEL	1	

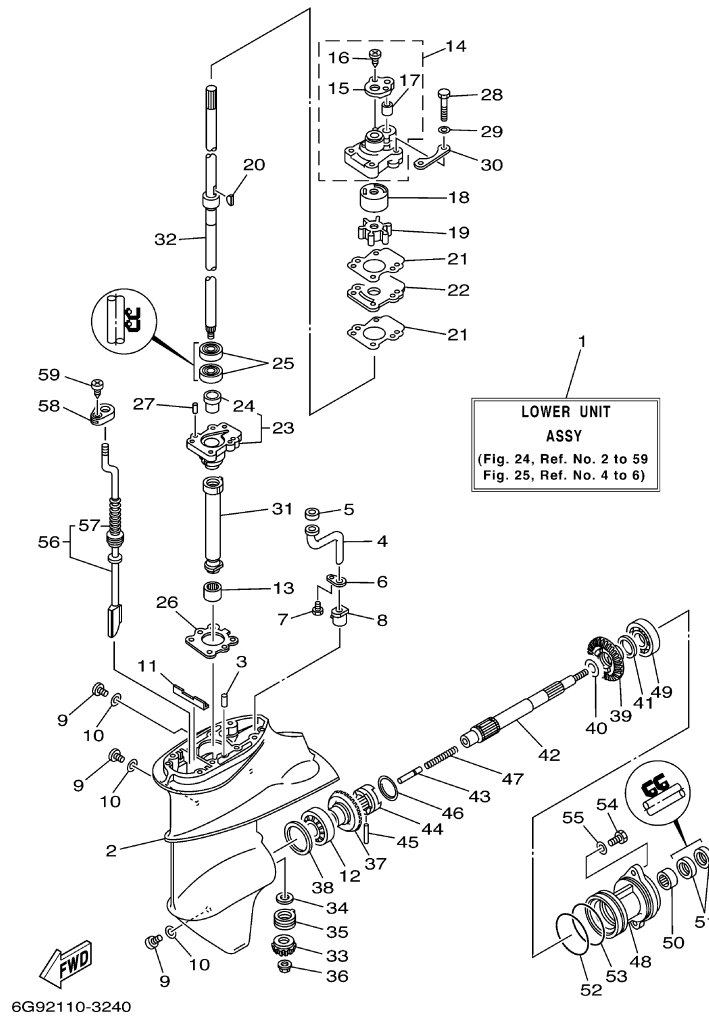
F9.9MLHB 2003 / LOWER CASING DRIVE 1



©2014 Yamaha Motor Corporation, U.S.A. All rights reserved.

Part List

F9.9MLHB 2003 / LOWER CASING DRIVE 1

REF - NO	PART NUMBER	PART NAME	QUANTITY	REMARKS
1	6G9-45300-16-4D	LOWER UNIT ASSY	1	UR L
1	6G9-45300-06-4D	LOWER UNIT ASSY	1	UR S
2	6E8-45311-00-4D	CASING, LOWER	1	
3	93604-08062-00	PIN, DOWEL	1	
4	683-44362-01-00	TUBE, WATER	1	
5	683-44365-01-00	DAMPER, WATER SEAL	1	
6	683-44373-00-00	SET PLATE, WATER TUBE	1	
7	97095-06010-00	BOLT	1	
8	6E7-44366-00-00	DAMPER, WATER SEAL	1	
9	90340-08002-00	PLUG, STRAIGHT SCREW	3	
10	90430-08020-00	.GASKET	3	
11	682-45376-01-00	GUIDE, SEAL DAMPER	1	
12	93332-00005-00	BEARING	1	
13	93315-314V8-00	BEARING	1	
14	682-44300-01-00	HOUSING, WATER PUMP	1	
15	682-44312-00-00	.COVER, WATER PUMP HOUSING	1	
16	97780-40112-00	.SCREW, TAPPING	2	
17	682-44365-00-00	.DAMPER, WATER SEAL	1	
18	682-44322-00-00	INSERT, CARTRIDGE	1	
19	682-44352-01-00	IMPELLER	1	
20	90280-03024-00	.KEY, WOODRUFF	1	
21	682-44315-A0-00	GASKET, WATER PUMP	2	
22	682-44323-00-00	OUTER PLATE, CARTRIDGE	1	
23	6E7-45331-00-5B	HOUSING, BEARING	1	
24	626-45316-09-00	.BUSHING, DRIVE SHAFT	1	
25	93101-20048-00	.OIL SEAL	2	
26	683-45315-A0-00	PACKING, LOWER CASING	1	
27	93606-12019-00	.PIN, DOWEL	2	
28	97095-06045-00	.BOLT	4	
29	92995-06600-00	WASHER	4	
30	682-44328-00-00	PLATE	2	
31	6E7-45536-00-00	SLEEVE, DRIVE SHAFT	1	
32	6G9-45501-11-00	DRIVE SHAFT COMP.	1	UR L
32	6G9-45501-01-00	DRIVE SHAFT COMP.	1	UR S
33	6E7-45551-00-00	PINION (13T)	1	
34	6E8-45587-00-20	SHIM (T:1.20MM)	1	UR
34	6E8-45587-00-13	SHIM (T:1.13MM)	1	UR
35	93341-414V1-00	BEARING	1	
36	90179-08M06-00	NUT	1	
37	6E7-45560-01-00	GEAR 1 (27T)	1	
38	664-45567-01-12	SHIM (T:0.12MM)	1	UR
38	664-45567-01-30	SHIM (T:0.30MM)	1	UR
38	664-45567-01-50	SHIM (T:0.50MM)	1	UR
38	664-45567-01-40	SHIM (T:0.40MM)	1	UR
38	664-45567-01-15	SHIM (T:0.15MM)	1	UR
38	664-45567-01-18	SHIM (T:0.18MM)	1	UR
38	664-45567-01-10	SHIM (T:0.10MM)	1	UR
39	6E7-45571-00-00	GEAR 2 (27T)	1	
40	90201-17682-00	WASHER, PLATE	1	
41	626-45577-00-01	SHIM (T:0.10MM)	1	UR
41	626-45577-00-05	SHIM (T:0.50MM)	1	UR
41	626-45577-00-03	SHIM (T:0.30MM)	1	UR
42	683-45611-00-00	SHAFT, PROPELLER	1	
43	650-45635-00-00	PLUNGER, SHIFT	1	
44	682-45631-00-00	CLUTCH, DOG	1	
45	90250-05010-00	PIN, STRAIGHT	1	
46	648-45633-00-00	RING, CROSS PIN	1	
47	90501-14M06-00	SPRING, COMPRESSION	1	
48	683-45361-02-4D	CAP, LOWER CASING	1	

49	93306-00501-00	BEARING	1	
50	93315-317U2-00	BEARING	1	
51	93101-17054-00	.OIL SEAL	2	
52	93210-57M09-00	.O-RING	1	
53	93210-56M80-00	.O-RING	1	
54	97095-06020-00	BOLT	2	
55	92995-06600-00	WASHER	2	
56	6G9-44150-10-00	SHIFT CAM ASSY.	1	UR L
56	6G9-44150-00-00	SHIFT CAM ASSY.	1	UR S
57	682-44147-00-00	.BOOT, SHIFT ROD	1	
58	682-44176-00-00	BRACKET	1	
59	97780-50510-00	SCREW, TAPPING	1	

Part Notes

F9.9MLHB 2003 / LOWER CASING DRIVE 1

PART NUMBER	NOTE TEXT
90430-08020-00 	OEM: This part number is among the Top 100 Most Popular Marine Maintenance Parts as of March 2014.

©2014 Yamaha Motor Corporation, U.S.A. All rights reserved.

F9.9MLHB 2003 / LOWER CASING DRIVE 2

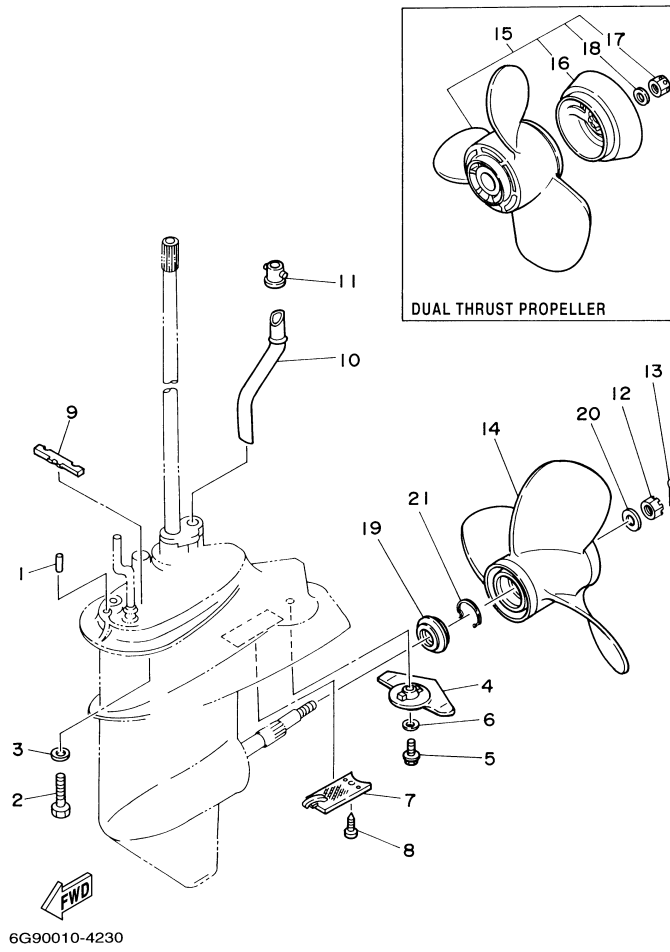

Part List

F9.9MLHB 2003 / LOWER CASING DRIVE 2

REF - NO	PART NUMBER	PART NAME	QUANTITY	REMARKS
1	93606-12019-00	.PIN, DOWEL	2	
2	97075-08035-00	BOLT	4	
3	92995-08600-00	WASHER	4	
4	6E8-45251-02-00	ANODE	1	
5	95895-06020-00	BOLT, FLANGE	1	
6	92990-06300-00	WASHER, INTERNAL TOOTH	1	
7	6E7-45214-00-00	COVER, WATER INLET 1	1	
8	97880-05012-00	SCREW, PAN HEAD	1	
9	682-45375-01-00	DAMPER, SEAL	1	
10	6G9-44361-00-00	TUBE, WATER	1	UR S
10	6G8-44361-10-00	TUBE, WATER	1	UR L
11	626-44365-01-00	DAMPER, WATER SEAL	1	
12	90171-10M01-00	NUT, CASTLE	1	
13	91490-30020-00	PIN. COTTER	1	
14	683-45943-00-EL	PROPELLER (3X9-1/4"X10-1/2"-J)	1	UR
14	683-45945-00-EL	PROPELLER (3X9-1/4"X9"-J)	1	UR
14	683-45947-00-EL	PROPELLER (3X9-1/4"X8"-J)	1	UR
14	63V-45945-00-EL	PROPELLER (3X9-1/4"X9"-J)	1	UR
14	683-45941-00-EL	PROPELLER (3X9-1/4"X12"-J)	1	UR
14	683-45949-00-EL	PROPELLER (3X9-1/2"X6-1/2"-J)	1	UR
14	63V-45947-00-EL	PROPELLER (3X9-1/4"X8"-J)	1	UR
14	683-45952-00-EL	PROPELLER (3X9-1/4"X9-3/4"-J)	1	UR
15	683-W4592-02-EL	PROPELLER (3X9-3/4"X6-1/2"-J)	1	UR DUAL THRUST PROP.
15	683-W4591-02-EL	PROPELLER (3X9-3/4"X8"-J)	1	UR DUAL THRUST PROP.
16	6E7-45986-00-00	.RING, DEFLECTOR	1	
17	90171-10M07-00	.NUT, CASTLE	1	
18	90201-10M02-00	.WASHER, PLATE	1	
19	6G9-45987-00-00	SPACER	1	
20	90201-10M01-00	WASHER, PLATE	1	
21	93450-10M05-00	CIRCLIP	1	

F9.9MLHB 2003 / STEERING GUIDE

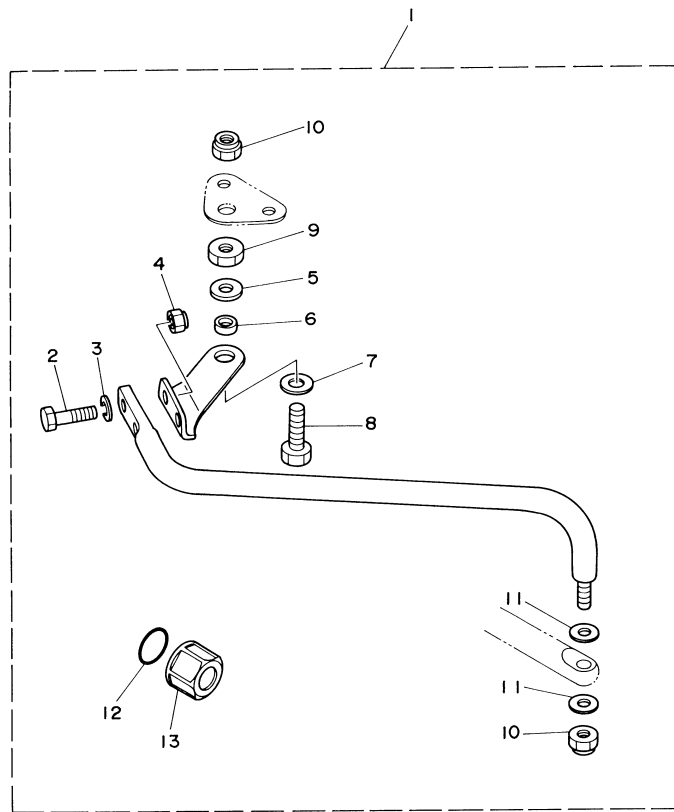

6G80100-9270

Part List

F9.9MLHB 2003 / STEERING GUIDE

REF - NO	PART NUMBER	PART NAME	QUANTITY	REMARKS
1	6G8-61350-00-00	STEERING GUIDE ATTACHMENT KIT	1	AP ER
2	97075-08025-00	.BOLT	2	
3	92995-08600-00	.WASHER	2	
4	90185-08057-00	.NUT, SELF-LOCKING	2	
5	90201-10M04-00	.WASHER, PLATE	1	
6	90387-10M06-00	.COLLAR	1	
7	90201-10M63-00	.WASHER, PLATE	1	
8	6E5-61355-00-00	.BOLT	1	
9	90170-09M03-00	.NUT	1	
10	90185-09M01-00	.NUT, SELF-LOCKING	2	
11	90201-10M20-00	.WASHER, PLATE	2	
12	93210-16275-00	.O-RING	1	
13	6E5-43145-01-00	.CAP, CLAMP BRACKET	1	

F9.9MLHB 2003 / OPTIONAL PARTS

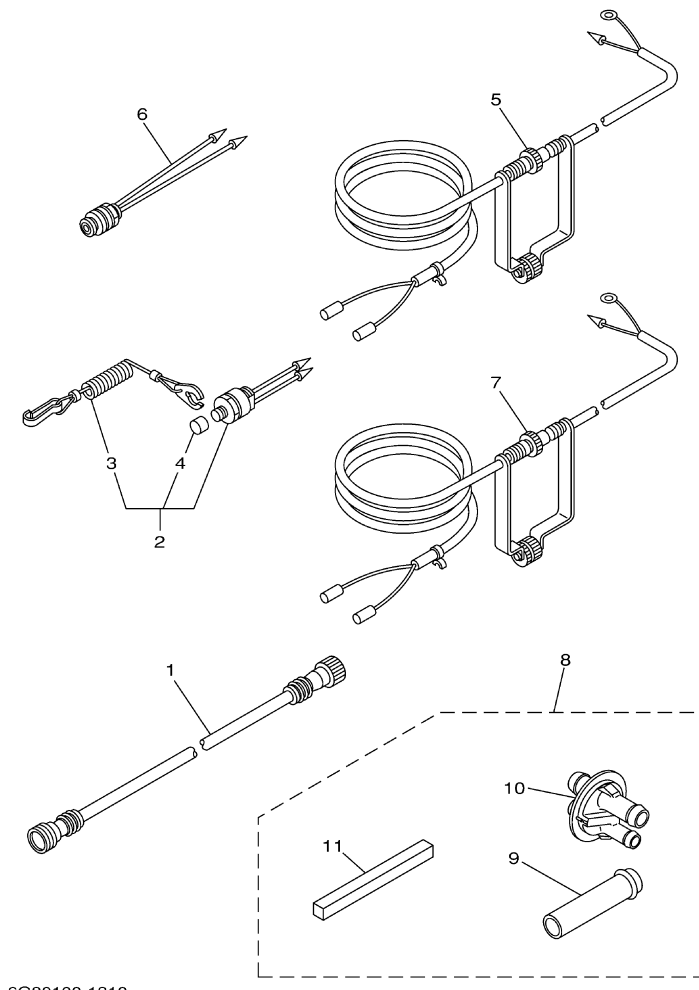

6G80100-1310

Part List

F9.9MLHB 2003 / OPTIONAL PARTS

REF - NO	PART NUMBER	PART NAME	QUANTITY	REMARKS
1	689-82553-10-00	EXTENSION, WIRE LEAD	1	AP
2	689-82575-14-00	ENGINE STOP SWITCH ASSY	1	AP
3	682-82556-00-00	.LANYARD, STOP SWITCH	1	
4	689-8257Y-00-00	.CAP	1	
5	6A0-82553-20-00	EXTENSION, WIRE LEAD	1	AP
6	689-82550-11-00	ENGINE STOP SWITCH ASSY	1	AP
7	6A0-82553-20-00	EXTENSION, WIRE LEAD	1	AP
8	6G8-W4537-00-00	WELL-TYPE EXHAUST KIT	1	AP
9	6G8-14611-00-00	.PIPE, EXHAUST 1	1	
10	6G8-44391-10-00	.NIPPLE, HOSE	1	
11	6G8-45375-10-00	.DAMPER, SEAL	1	

Part Notes

F9.9MLHB 2003 / OPTIONAL PARTS

PART NUMBER	NOTE TEXT
682-82556-00-00 	OEM: This part number is among the Top 100 Most Popular Marine Maintenance Parts as of March 2014.

©2014 Yamaha Motor Corporation, U.S.A. All rights reserved.

F9.9MLHB 2003 / REPAIR KIT 1

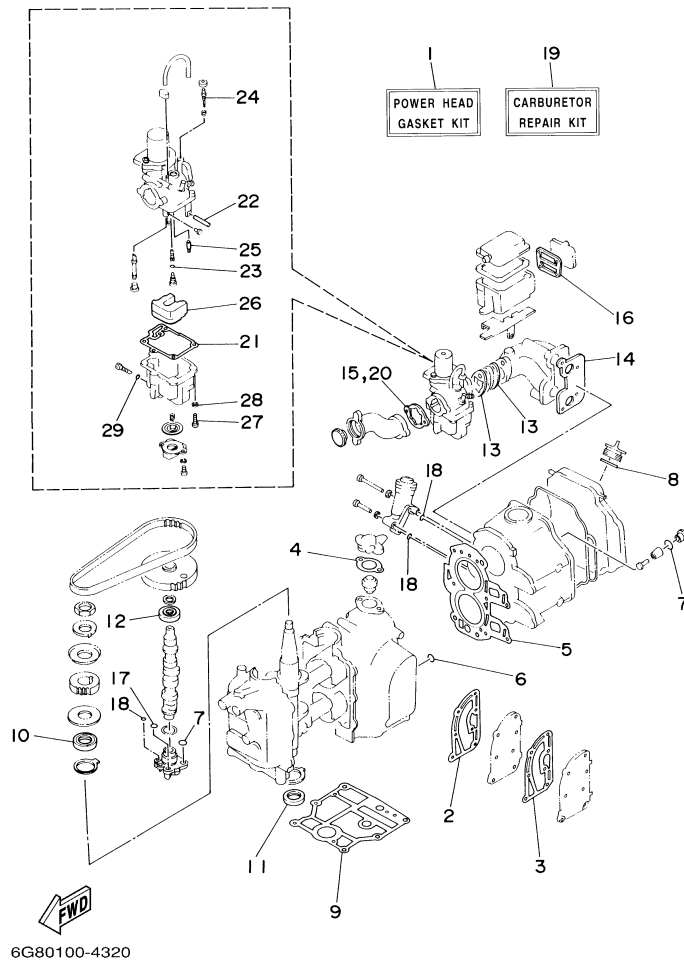

©2014 Yamaha Motor Corporation, U.S.A. All rights reserved.

Part List

F9.9MLHB 2003 / REPAIR KIT 1

REF - NO	PART NUMBER	PART NAME	QUANTITY	REMARKS
1	6G8-W0001-A3-00	POWER HEAD GASKET KIT	1	
2	6G8-41112-02-00	.GASKET, EXHAUST INNER COVER	1	
3	6G8-41114-00-00	.GASKET, EXHAUST OUTER COVER	1	
4	6G8-12414-A0-00	.GASKET, COVER	1	
5	6G8-11181-A1-00	.GASKET, CYLINDER HEAD 1	1	
6	93210-11M59-00	.O-RING	1	
7	93210-13M63-00	.O-RING	3	
8	93210-24M79-00	.O-RING	1	
9	6G8-11351-A0-00	.GASKET, CYLINDER	1	
10	93102-30M22-00	.OIL SEAL	1	
11	93101-25M24-00	.OIL SEAL	1	
12	93102-18M21-00	.OIL SEAL	1	
13	6G8-13646-A0-00	.GASKET, MANIFOLD 2	2	
14	6G8-13645-00-00	.GASKET, MANIFOLD 1	1	
15	6G8-14198-A0-00	.GASKET	1	
16	6G8-15374-00-00	.GASKET, BREATHER	1	
17	93210-10M61-00	.O-RING	1	
18	93210-09M01-00	.O-RING	3	
19	6G8-W0093-03-00	CARBURETOR REPAIR KIT	1	
20	6G8-14198-A0-00	.GASKET	1	
21	6G8-14384-01-00	.GASKET, FLOAT CHAMBER	1	
22	647-14386-00-00	.PIN, FLOAT	1	
23	654-14198-00-00	.GASKET	1	
24	6G8-14323-00-00	.SCREW, AIR ADJUSTING	1	
25	6G8-14392-00-00	.VALVE, NEEDLE	1	
26	6G8-14385-00-00	.FLOAT	1	
27	98580-04016-00	.SCREW, PAN HEAD	1	
28	92990-04100-00	.WASHER, SPRING	1	
29	5Y1-14397-00-00	.O-RING	1	

F9.9MLHB 2003 / REPAIR KIT 2

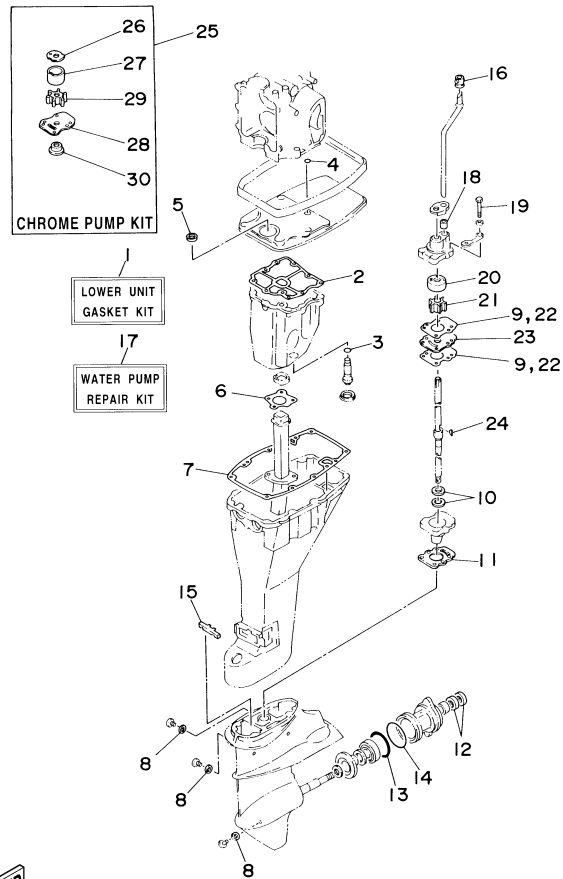

6G90100-4330

Part List

F9.9MLHB 2003 / REPAIR KIT 2

REF - NO	PART NUMBER	PART NAME	QUANTITY	REMARKS
1	6G9-W0001-C6-00	LOWER UNIT GASKET KIT	1	
2	6G8-15312-A1-00	.GASKET, OIL PAN	1	
3	93210-16M64-00	.O-RING	1	
4	93210-08M60-00	.O-RING	1	
5	93101-13M27-00	.O-RING	1	
6	6G8-41133-A0-00	.GASKET, EXHAUST MANIFOLD 1	1	
7	6G8-45113-A1-00	.GASKET, UPPER CASING	1	
8	90430-08020-00	.GASKET	3	
9	682-44315-A0-00	.GASKET, WATER PUMP	2	
10	93101-20048-00	.OIL SEAL	2	
11	683-45315-A0-00	.PACKING, LOWER CASING	1	
12	93101-17054-00	.OIL SEAL	2	
13	93210-57M09-00	.O-RING	1	
14	93210-56M80-00	.O-RING	1	
15	682-45375-01-00	.DAMPER, SEAL	1	
16	626-44365-01-00	.DAMPER, WATER SEAL	1	
17	682-W0078-A2-00	WATER PUMP REPAIR KIT	1	
18	682-44365-00-00	.DAMPER, WATER SEAL	1	
19	97095-06045-00	.BOLT	4	
20	682-44322-00-00	.INSERT, CARTRIDGE	1	
21	682-44352-01-00	.IMPELLER	1	
22	682-44315-A0-00	.GASKET, WATER PUMP	2	
23	682-44323-00-00	.OUTER PLATE, CARTRIDGE	1	
24	90280-03024-00	.KEY, WOODRUFF	1	
25	682-W0078-0A-00	CHROME PUMP KIT	1	
26	682-44321-40-00	.INNER PLATE, CARTRIDGE	1	
27	682-44322-40-00	.INSERT, CARTRIDGE	1	
28	682-44323-40-00	.OUTER PLATE, CARTRIDGE	1	
29	682-44352-01-00	.IMPELLER	1	
30	682-45344-00-00	.COVER, OIL SEAL	1	

Part Notes

F9.9MLHB 2003 / REPAIR KIT 2

PART NUMBER	NOTE TEXT
90430-08020-00 	OEM: This part number is among the Top 100 Most Popular Marine Maintenance Parts as of March 2014.

©2014 Yamaha Motor Corporation, U.S.A. All rights reserved.

F9.9MLHB 2003 / MODELS IN THIS CATALOG

F9.9MSHB (6G92)

Engine Serial No. (F9.9MSHB): 6G9S-100022 and following

F9.9MLHB (6G92)

Engine Serial No. (F9.9MLHB): 6G9L-100055 and following

F9.9ELRB (6G92)

Engine Serial No. (F9.9ELRB): 6G9L-100001 and following

**ALL THESE MODELS USE THIS SAME PARTS CATALOG.
BE SURE TO ORDER ONLY THOSE PARTS APPLICABLE
TO THE DESIRED MODEL.**

©2014 Yamaha Motor Corporation, U.S.A. All rights reserved.

©2014 Yamaha Motor Corporation, U.S.A. All rights reserved.