

F9.9ELRX 1999 / CYLINDER CRANKCASE

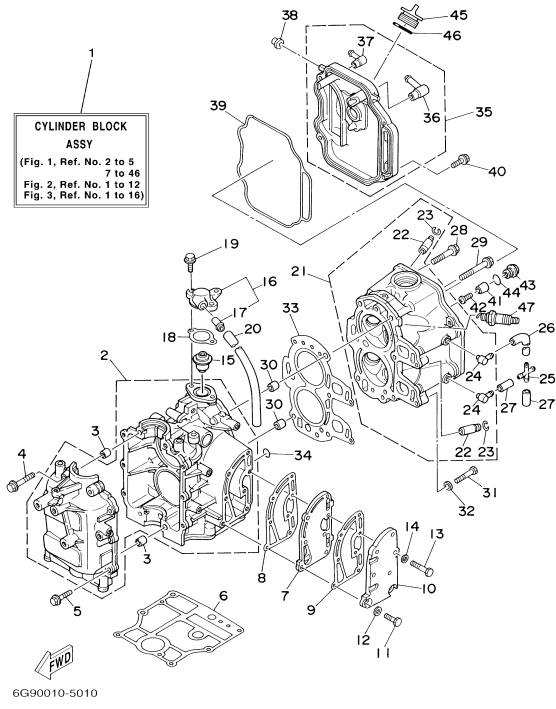

## Part List

F9.9ELRX 1999 / CYLINDER CRANKCASE

REF - NO	PART NUMBER	PART NAME	QUANTITY	REMARKS
1	6G8-W0090-33-1S	CRANK CYLINDER ASSY	1	
2	6G8-15100-05-1S	CRANKCASE ASSY	1	
3	99510-10114-00	PIN, DOWEL	2	
4	90119-08M18-00	BOLT, WITH WASHER	4	
5	90119-06M12-00	BOLT, WITH WASHER	6	
6	6G8-11351-A0-00	GASKET, CYLINDER	1	
7	6G8-41111-02-1S	INNER COVER, EXHAUST	1	
8	6G8-41112-02-00	GASKET, EXHAUST INNER COVER	1	
9	6G8-41114-00-00	GASKET, EXHAUST OUTER COVER	1	
10	6G8-41113-10-1S	OUTER COVER, EXHAUST	1	
11	97013-06025-00	BOLT	2	
12	92903-06600-00	WASHER, PLATE	2	
13	97013-06030-00	BOLT	5	
14	92903-06600-00	WASHER, PLATE	5	
15	6G8-12411-02-00	THERMOSTAT	1	
16	6G8-12413-00-1S	COVER, THERMOSTAT	1	
17	6E5-24377-00-00	.PIPE, JOINT 2	1	
18	6G8-12414-A0-00	.GASKET, COVER	1	
19	97513-06520-00	BOLT, WITH WASHER	2	
20	90445-11M66-00	.HOSE (L410)	1	
21	6G8-11111-03-1S	HEAD, CYLINDER 1	1	
22	6G8-11133-10-00	.GUIDE, VALVE 1	4	
23	93450-09M01-00	.CIRCLIP	4	
24	676-11372-00-00	.NIPPLE, HOSE	2	
25	6G9-24379-00-00	PIPE, JOINT 4	1	
26	6G8-12481-01-00	PIPE 1	1	
27	90445-09220-00	HOSE (L30)	2	
28	90105-08M37-00	BOLT, FLANGE	3	
29	90105-08M36-00	BOLT, FLANGE	3	
30	99510-10114-00	PIN, DOWEL	2	
31	97013-06035-00	BOLT	2	
32	92903-06600-00	WASHER, PLATE	2	
33	6G8-11181-A1-00	GASKET, CYLINDER HEAD 1	1	
34	93210-11M59-00	O-RING	1	
35	6G8-11191-01-1S	COVER, CYLINDER HEAD 1	1	
36	6G8-15373-00-00	.PIPE, BREATHER	1	
37	676-11372-00-00	.NIPPLE, HOSE	1	
38	6G8-81336-00-00	GROMMET	2	
39	6G8-11356-00-00	SEAL, CYLINDER 2	1	
40	97513-06520-00	BOLT, WITH WASHER	4	
41	6G8-11325-00-00	ANODE	1	
42	97880-05025-00	SCREW, PAN HEAD	1	
43	6G8-11197-00-00	PLUG, BLIND	1	
44	93210-13M63-00	.O-RING	1	
45	6G8-15363-00-00	PLUG, OIL	1	
46	93210-24M79-00	.O-RING	1	
47	94701-00282-00	PLUG SPARK (NGK CR6HS)	2	

F9.9ELRX 1999 / CRANKSHAFT PISTON

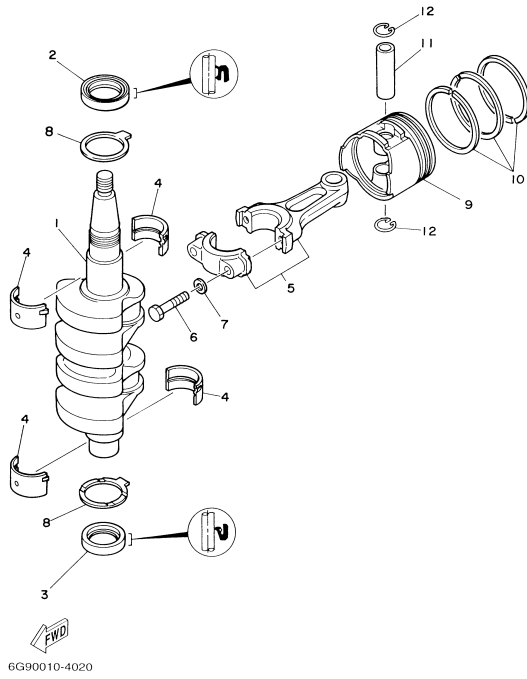

## Part List

F9.9ELRX 1999 / CRANKSHAFT PISTON

REF - NO	PART NUMBER	PART NAME	QUANTITY	REMARKS
1	6G8-11411-04-00	CRANKSHAFT	1	
2	93102-30M22-00	.OIL SEAL	1	
3	93101-25M24-00	OIL SEAL	1	
4	6G8-11416-00-00	PLANE BEARING, CRANKSHAFT 1	4	UR BROWN
4	6G8-11416-10-00	PLANE BEARING, CRANKSHAFT 1	4	UR BLACK
4	6G8-11416-20-00	PLANE BEARING, CRANKSHAFT 1	4	UR BLUE
5	6G8-11650-03-00	CONNECTING ROD ASSY	2	
6	6G8-11654-00-00	BOLT, CONNECTING ROD	4	
7	90201-06M00-00	WASHER, PLATE	4	
8	6G8-11426-00-00	PLANE BEARING, CRANKSHAFT 1	2	
9	6G8-11636-03-00	PISTON (0.50MM O/S)	2	AP
9	6G8-11635-03-00	PISTON (0.25MM O/S)	2	AP
9	6G8-11631-03-96	PISTON (STD)	2	
10	6G8-11610-02-00	PISTON RING SET (STD)	2	
10	6G8-11610-22-00	PISTON RING SET (0.50MM O/S)	2	AP
10	6G8-11610-12-00	PISTON RING SET (0.25MM O/S)	2	AP
11	634-11633-00-00	PIN, PISTON	2	
12	93450-15023-00	CIRCLIP	4	

F9.9ELRX 1999 / VALVE

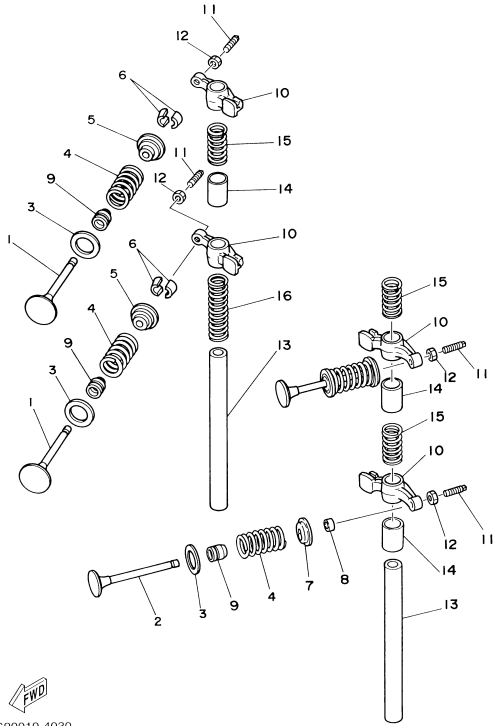

6G90010-4030

©2014 Yamaha Motor Corporation, U.S.A. All rights reserved.

## Part List

F9.9ELRX 1999 / VALVE

REF - NO	PART NUMBER	PART NAME	QUANTITY	REMARKS
1	6G8-12111-00-00	VALVE, INTAKE	2	
2	6G8-12121-01-00	VALVE, EXHAUST	2	
3	6G8-12116-00-00	SEAT, VALVE SPRING	4	
4	6G8-12113-00-00	SPRING, VALVE INNER	4	
5	6G8-12117-00-00	RETAINER, VALVE SPRING	2	
6	30X-12118-00-00	LOCK, VALVE SPRING RETAINER	4	
7	6G8-12117-10-00	RETAINER, VALVE SPRING	2	
8	6G8-12153-00-00	LIFTER, VALVE	2	
9	51Y-12119-00-00	SEAL, VALVE STEM	4	
10	6G8-12151-00-00	ARM, VALVE ROCKER	4	
11	6G8-12159-00-00	SCREW, VALVE ADJUSTING	4	
12	6G8-12158-00-00	NUT, LOCK	4	
13	6G8-12146-00-00	SHAFT, ROCKER	2	
14	90387-13M56-00	COLLAR	3	
15	90501-12M40-00	SPRING, COMPRESSION	3	
16	90501-12M41-00	SPRING, COMPRESSION	1	

F9.9ELRX 1999 / INTAKE

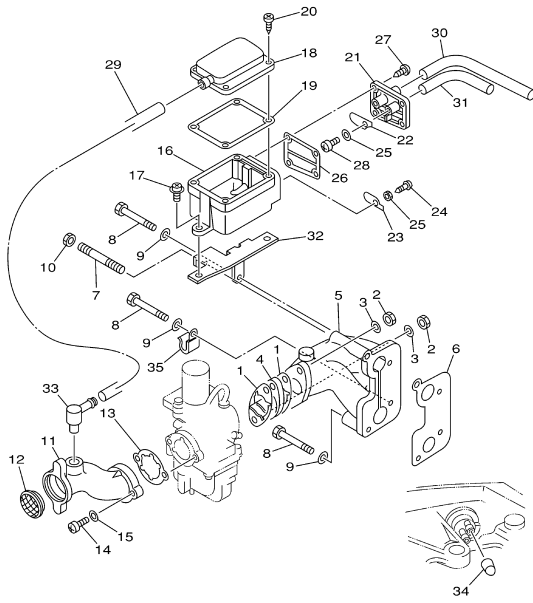

  
6G80110-9040

Part List *F9.9ELRX 1999 / INTAKE*

REF - NO	PART NUMBER	PART NAME	QUANTITY	REMARKS
1	6G8-13646-A0-00	GASKET, MANIFOLD 2	2	
2	95380-06700-00	NUT	2	
3	92990-06600-00	WASHER, PLATE	2	
4	6G8-13647-00-00	GASKET, MANIFOLD 3	1	
5	6G8-13641-01-94	MANIFOLD 1	1	
6	6G8-13645-00-00	GASKET, MANIFOLD 1	1	
7	90116-06M15-00	BOLT, STUD	1	
8	97095-06045-00	.BOLT	3	
9	92995-06600-00	WASHER	3	
10	95380-06700-00	NUT	1	
11	6G8-14479-10-94	FUNNEL	1	
12	6G8-14478-00-00	LOUVER	1	
13	6G8-14198-A0-00	.GASKET	1	
14	97880-05016-00	SCREW, PAN HEAD	2	
15	92990-05600-00	WASHER, PLATE	2	
16	6G8-15358-00-00	SEPARATOR, OIL	1	
17	90159-06M05-00	SCREW, WITH WASHER	2	
18	6G8-15368-00-94	SEPERATOR, OIL	1	
19	6G8-15369-00-00	GASKET, OIL SEAL HOUSING	1	
20	97780-40512-00	SCREW, TAPPING	4	
21	6G8-15371-00-94	BREATHER	1	
22	6G8-15346-00-00	BREATHER 1	1	
23	6G8-15347-00-00	BREATHER 2	1	
24	97780-40512-00	SCREW, TAPPING	1	
25	92990-04200-00	WASHER	2	
26	6G8-15374-00-00	GASKET, BREATHER	1	
27	97780-40512-00	SCREW, TAPPING	4	
28	98507-04010-00	SCREW, PAN HEAD	1	
29	6G8-15393-10-00	PIPE, BREATHER 2	1	
30	90445-11M52-00	HOSE (L150)	1	
31	90445-09065-00	HOSE (L90)	1	
32	6G8-15376-00-00	HOLDER, GUIDE	1	
33	6G8-15373-00-00	PIPE, BREATHER	1	
34	6G8-13448-00-00	CAP	1	
35	90465-08M75-00	CLAMP	1	

Part Notes *F9.9ELRX 1999 / INTAKE*

PART NUMBER	NOTE TEXT
92990-06600-00 	OEM: This part number is among the Top 100 Most Popular Marine Maintenance Parts as of March 2014.

©2014 Yamaha Motor Corporation, U.S.A. All rights reserved.



F9.9ELRX 1999 / CARBURETOR

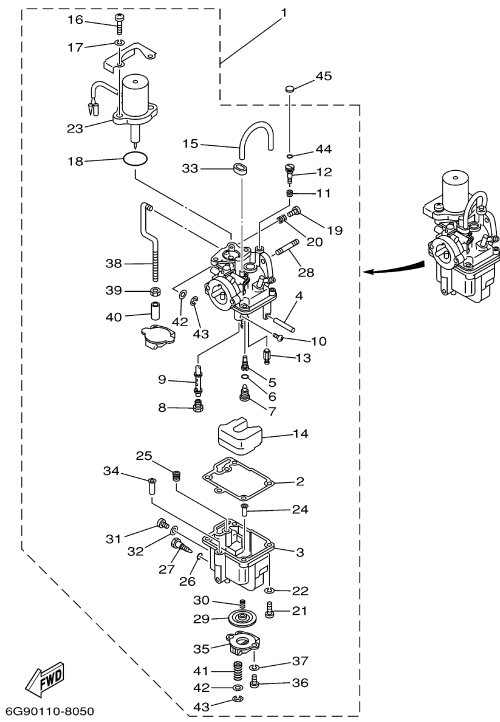

## Part List

F9.9ELRX 1999 / CARBURETOR

REF - NO	PART NUMBER	PART NAME	QUANTITY	REMARKS
1	6G9-14301-20-00	CARBURETOR ASSY 1	1	
2	6G8-14384-01-00	.GASKET, FLOAT CHAMBER	1	
3	6G8-14381-02-00	.BODY, FLOAT CHAMBER	1	
4	647-14386-00-00	.PIN, FLOAT	1	
5	6G8-14342-24-00	.JET, PILOT (#48)	1	
6	654-14198-00-00	.GASKET	1	
7	6G8-14345-00-00	.PLUG, MAIN NOZZLE	1	
8	648-14343-43-00	.JET, MAIN (#86)	1	
9	6G8-14341-20-00	.NOZZLE, MAIN	1	
10	6G8-14216-00-00	.SCREW	1	
11	647-14334-00-00	.SPRING	1	
12	6G8-14323-20-00	.SCREW, AIR ADJUSTING	1	
13	6G8-14392-00-00	.VALVE, NEEDLE	1	
14	6G8-14385-00-00	.FLOAT	1	
15	6G8-14197-01-00	.PIPE	1	
16	98580-06018-00	.SCREW, PAN HEAD	2	
17	92990-06100-00	.WASHER, SPRING	2	
18	1HV-14147-00-00	.O-RING	1	
19	664-14321-01-00	.SCREW, THROTTLE	1	
20	646-14212-00-00	.SPRING, PILOT ADJUSTING	1	
21	98580-04016-00	.SCREW, PAN HEAD	4	
22	92990-04100-00	.WASHER, SPRING	4	
23	6G8-1410A-01-00	.STARTER SET	1	
24	6G8-14827-00-00	.FILTER	1	
25	6A4-14344-30-00	.JET, STARTER (#60)	1	
26	5Y1-14397-00-00	.O-RING	1	
27	6G8-14383-00-00	.SCREW, DRAIN	1	
28	90116-06M26-00	.BOLT, STUD	2	
29	6G8-14368-02-00	.DIAPHRAGM ASSEMBLY	1	
30	6G8-14275-01-00	.SPRING	1	
31	97890-05006-00	.SCREW, PAN HEAD	1	
32	646-14198-01-00	.GASKET	1	
33	6G8-14349-00-00	.PIPE	1	
34	6G8-14217-00-00	.VALVE, CHOKE	1	
35	6G8-14293-03-00	.COVER 1	1	
36	98580-04010-00	.SCREW, PAN HEAD	2	
37	92990-04100-00	.WASHER, SPRING	2	
38	6G8-14379-00-00	.ROD, STARTER	1	
39	98813-03100-00	.NUT	1	
40	6G8-14229-00-00	.SHAFT, CHOKE	1	
41	6G8-14286-01-00	.SPRING	1	
42	6G8-14357-00-00	.WASHER, PLAIN	2	
43	389-14137-00-00	.CLIP	2	
44	5H0-14397-00-00	.O-RING	1	
45	6G8-1432A-00-00	.PLUG	1	

F9.9ELRX 1999 / OIL PUMP

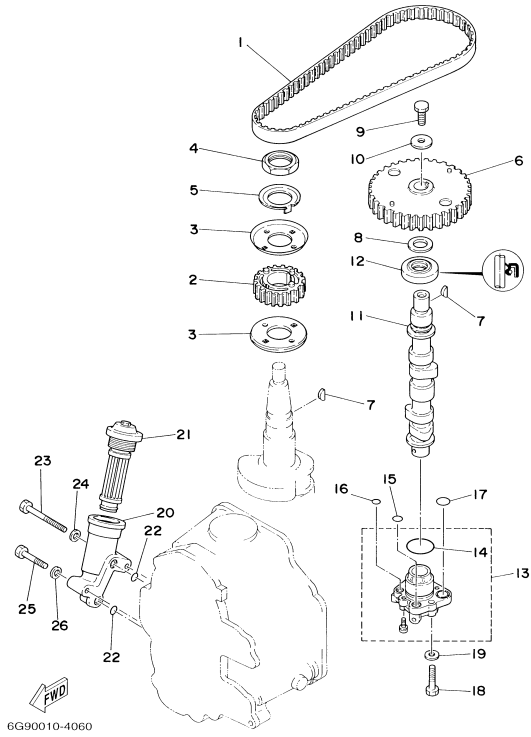

©2014 Yamaha Motor Corporation, U.S.A. All rights reserved.

## Part List

F9.9ELRX 1999 / OIL PUMP

REF - NO	PART NUMBER	PART NAME	QUANTITY	REMARKS
1	6G8-46241-00-00	V-BELT	1	
2	6G8-11536-00-94	GEAR, DRIVE	1	
3	6G8-11557-00-00	WASHER 1	2	
4	90170-24M09-00	NUT	1	
5	6G8-11587-00-00	WASHER, LOCK	1	
6	6G8-11537-00-94	GEAR, DRIVEN	1	
7	90280-03M01-00	.KEY, WOODRUFF	2	
8	90201-13201-00	WASHER, PLATE	1	
9	97013-06016-00	BOLT	1	
10	90201-06M94-00	WASHER, PLATE	1	
11	6G8-12171-00-00	CAMSHAFT 1	1	
12	93102-18M21-00	.OIL SEAL	1	
13	6G8-13300-02-00	OIL PUMP ASSY	1	
14	93210-27ME3-00	.O-RING	1	
15	93210-10M61-00	.O-RING	1	
16	93210-09M01-00	.O-RING	1	
17	93210-13M63-00	.O-RING	2	
18	97095-06025-00	BOLT	3	
19	92995-06600-00	WASHER	3	
20	6G8-13442-00-1S	HOUSING, OIL FILTER	1	
21	6G8-13440-00-00	ELEMENT ASSY,OIL CLEANER	1	
22	93210-09M01-00	.O-RING	2	
23	97013-06050-00	BOLT	1	
24	92903-06600-00	WASHER, PLATE	1	
25	97013-06030-00	BOLT	1	
26	92903-06600-00	WASHER, PLATE	1	

F9.9ELRX 1999 / OIL PAN

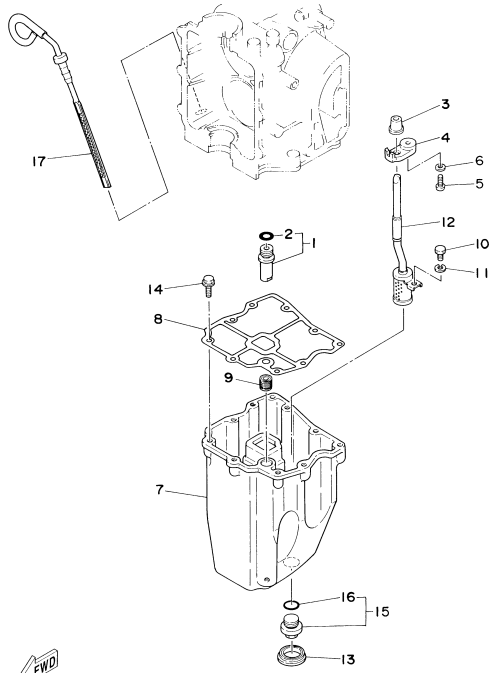

  
6G90010-4070

## Part List

F9.9ELRX 1999 / OIL PAN

REF - NO	PART NUMBER	PART NAME	QUANTITY	REMARKS
1	6G8-11575-00-00	RELIEF VALVE ASSY	1	
2	93210-12M62-00	.O-RING	1	
3	6G8-15379-00-00	SEAL, CRANKCASE	1	
4	6G8-13487-00-00	GUIDE, OIL HOSE	1	
5	97880-05012-00	SCREW, PAN HEAD	1	
6	92990-05600-00	WASHER, PLATE	1	
7	6G8-15311-03-0D	OIL PAN	1	
8	6G8-15312-A1-00	.GASKET, OIL PAN	1	
9	6G8-45127-00-00	SEAL	1	
10	97013-06010-00	BOLT	1	
11	92903-06100-00	WASHER, SPRING	1	
12	6G8-13421-00-00	STRAINER 2	1	
13	6G8-15316-00-00	DAMPER, ENGINE MOUNT 1	1	
14	90105-06M33-00	BOLT, FLANGE	9	
15	6G8-13471-00-00	PLUG, DRAIN	1	
16	93210-16M64-00	.O-RING	1	
17	6G8-15362-04-00	PLUG, OIL LEVEL	1	

F9.9ELRX 1999 / STARTER F9.9MH

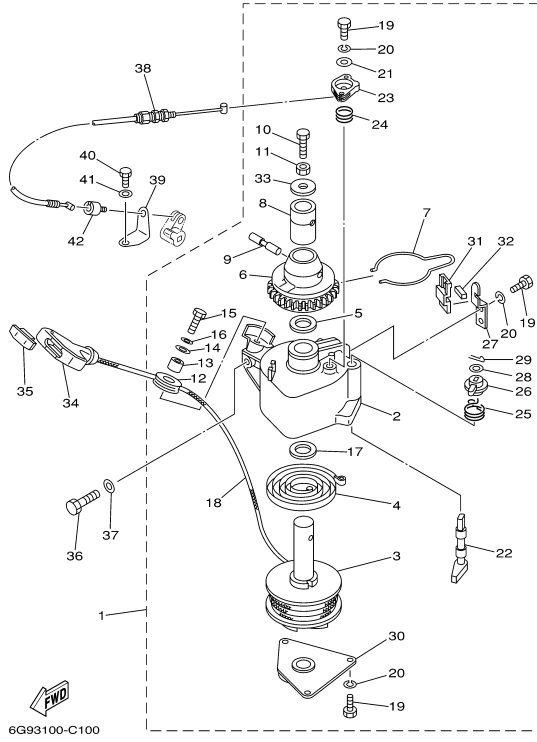

©2014 Yamaha Motor Corporation, U.S.A. All rights reserved.

## Part List

F9.9ELRX 1999 / STARTER F9.9MH

REF - NO	PART NUMBER	PART NAME	QUANTITY	REMARKS
1	6G8-15710-10-00	STARTER ASSY	1	(MH)
2	6G8-15711-00-00	.CASE, STARTER	1	(MH)
3	6G8-15714-00-00	.DRUM, SHEAVE	1	(MH)
4	6G8-15713-00-00	.SPRING, STARTER	1	(MH)
5	6G8-15719-00-00	.WASHER, THRUST	1	(MH)
6	6G8-15723-00-00	.PULLEY, STARTER	1	(MH)
7	6G8-15715-00-00	.SPRING, FRICTION	1	(MH)
8	6G8-15754-00-00	.BUSH 2	1	(MH)
9	6G8-15727-00-00	.PIN	1	(MH)
10	6G8-15768-00-00	.BOLT	1	(MH)
11	95333-08700-00	.NUT	1	(MH)
12	6F5-15752-00-00	.ROLLER, WIRE	1	(MH)
13	663-15753-00-00	.BUSH	1	(MH)
14	663-15791-00-00	.WASHER, LOCK	1	(MH)
15	97305-06025-00	.BOLT	1	(MH)
16	92903-06100-00	.WASHER, SPRING	1	(MH)
17	6G8-15739-00-00	.WASHER, THRUST	1	(MH)
18	90580-50M01-00	.ROPE, STARTER	1	(MH)
19	97322-05012-00	.BOLT	6	(MH)
20	92902-05100-00	.WASHER, SPRING	6	(MH)
21	6G8-15726-00-00	.WASHER, FLAT	1	(MH)
22	6G8-15794-00-00	.STOPPER	1	(MH)
23	6G8-15746-00-00	.ARM	1	(MH)
24	6G8-15767-00-00	.SPRING	1	(MH)
25	6G8-15734-00-00	.SPRING, RETURN	1	(MH)
26	6G8-15747-00-00	.LINK	1	(MH)
27	6G8-15716-00-00	.PLATE, DRIVE	1	(MH)
28	92902-06200-00	.WASHER	1	(MH)
29	91490-16012-00	.PIN, COTTER	1	(MH)
30	6G8-15712-00-00	.COVER, STARTER CASE	1	(MH)
31	6G8-15779-00-00	.COVER	1	(MH)
32	6G8-15789-00-00	.DAMPER	1	(MH)
33	6G8-15742-00-00	.WASHER, DRIVE PAWL	1	(MH)
34	6G1-15755-00-00	.HANDLE, STARTER	1	(MH)
35	689-15779-01-00	COVER	1	(MH)
36	97075-08030-00	BOLT	3	(MH)
37	92995-08600-00	WASHER	3	(MH)
38	6G8-15770-00-00	CABLE COMP., STARTER STOP	1	(MH)
39	6G8-15771-00-00	STAY 1	1	(MH)
40	97095-06012-00	BOLT	1	(MH)
41	92995-06600-00	WASHER	1	(MH)
42	6G8-15772-00-00	STAY 2	1	(MH)



F9.9ELRX 1999 / FUEL

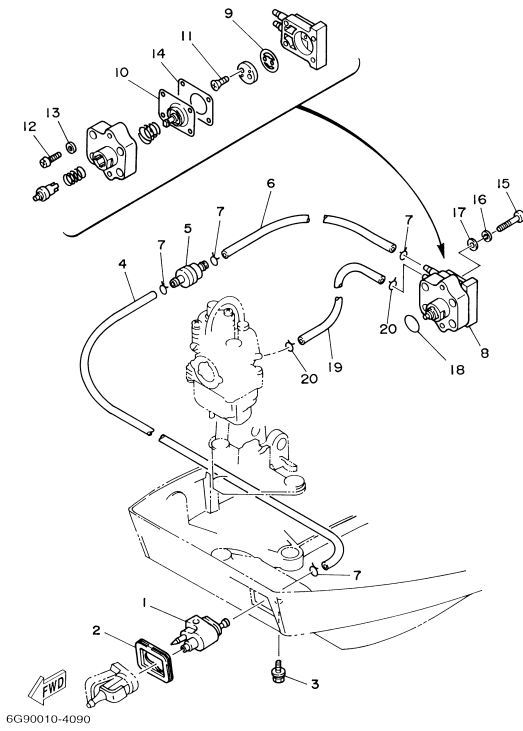



©2014 Yamaha Motor Corporation, U.S.A. All rights reserved.

Part List F9.9ELRX 1999 / FUEL

REF - NO	PART NUMBER	PART NAME	QUANTITY	REMARKS
1	6G1-24304-02-00	FUEL PIPE JOINT COMP. 1	1	
2	6G8-24329-00-00	SEAL	1	
3	97595-06520-00	BOLT, WITH WASHER	1	
4	6G8-24311-00-00	PIPE, FUEL 1	1	
5	646-24251-02-00	.STRAINER 1	1	
6	90445-09065-00	HOSE (L90)	1	
7	90467-08004-00	CLIP	4	
8	6G8-24410-03-00	FUEL PUMP ASSY	1	
9	6G8-24421-00-00	.VALVE, CHECK	1	
10	6G8-24411-02-00	.DIAPHRAGM	1	
11	98780-03008-00	.SCREW, FLAT HEAD	2	
12	98503-04014-00	.SCREW, PAN HEAD	4	
13	92903-04600-00	.WASHER	4	
14	6G8-24471-00-00	.DIAPHRAGM	1	
15	97880-06025-00	SCREW, PAN HEAD	2	
16	92990-06100-00	..WASHER, SPRING	2	
17	92990-06600-00	WASHER, PLATE	2	
18	93210-20M65-00	.O-RING	1	
19	90445-09105-00	HOSE (L300)	1	
20	90467-08004-00	CLIP	2	

Part Notes F9.9ELRX 1999 / FUEL

PART NUMBER	NOTE TEXT
646-24251-02-00	 OEM: This part number is among the Top 100 Most Popular Marine Maintenance Parts as of March 2014.
6G8-24410-03-00	 OEM: The new pump has two additional barbs installed in the base so that cooling water from the overboard water pump indicator can be routed through the fuel pump to prevent vapor lock condit
92990-06600-00	 OEM: This part number is among the Top 100 Most Popular Marine Maintenance Parts as of March 2014.

©2014 Yamaha Motor Corporation, U.S.A. All rights reserved.

F9.9ELRX 1999 / FUEL 2

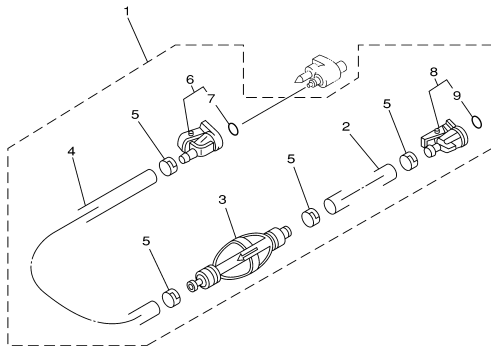

6960100-0050

## Part List

F9.9ELRX 1999 / FUEL 2

REF - NO	PART NUMBER	PART NAME	QUANTITY	REMARKS
1	6Y1-24306-51-00	FUEL PIPE COMP. 1	1	AP
2	90445-11M06-00	.HOSE (L2050)	1	
3	6Y1-24360-51-00	.PRIMER PUMP ASSY	1	
4	90445-11M05-00	.HOSE (L850)	1	
5	650-24351-51-00	.BAND 1	4	
6	6G1-24305-01-00	.FUEL PIPE JOINT COMP 2	1	
7	93210-08287-00	..O-RING	1	
8	6Y1-24305-02-00	.FUEL PIPE JOINT COMP 2	1	
9	93210-08287-00	..O-RING	1	

F9.9ELRX 1999 / TOP COWLING

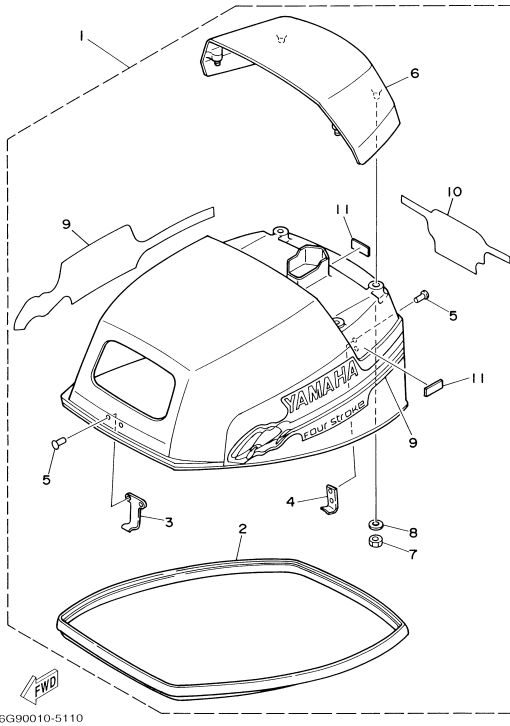

©2014 Yamaha Motor Corporation, U.S.A. All rights reserved.

## Part List

F9.9ELRX 1999 / TOP COWLING

REF - NO	PART NUMBER	PART NAME	QUANTITY	REMARKS
1	6G9-42610-14-4D	TOP COWLING ASSY	1	
2	6G8-42615-01-00	.SEAL	1	
3	6G8-42651-00-00	.HOOK	1	
4	6G8-42652-00-00	.HOOK	1	
5	90266-04M04-00	.RIVET	4	
6	6G8-42613-01-4D	.MOLDING, AIR DUCT	1	
7	95303-06700-00	.NUT	4	
8	92903-06200-00	.WASHER, PLAIN	4	
9	6G9-W0070-13-00	.GRAPHIC SET	1	
10	6G9-42678-13-00	.GRAPHIC, REAR	1	
11	6G8-42662-00-00	.DAMPER	3	

F9.9ELRX 1999 / BOTTOM COWLING

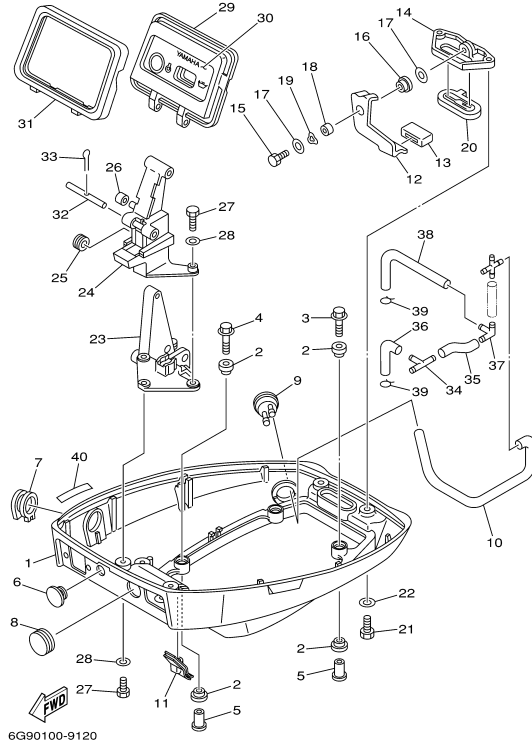

©2014 Yamaha Motor Corporation, U.S.A. All rights reserved.

## Part List

F9.9ELRX 1999 / BOTTOM COWLING

REF - NO	PART NUMBER	PART NAME	QUANTITY	REMARKS
1	6G8-42711-02-4D	COWLING, BOTTOM 1	1	
2	90480-09M35-00	GROMMET	8	
3	90119-06M56-00	BOLT, WITH WASHER	2	
4	90119-06M55-00	BOLT, WITH WASHER	2	
5	90387-06M15-00	COLLAR	4	
6	90480-17165-00	GROMMET	1	ER (ER)
7	6G9-42724-00-00	GROMMET	1	UR MH (MH)
7	6G8-42724-00-00	GROMMET	1	UR ER (ER)
8	6G8-42725-10-00	GROMMET	1	MH (MH)
9	6G8-44391-00-00	NIPPLE, HOSE	1	
10	90445-09163-00	HOSE (L235)	1	
11	6G8-42727-00-00	GROMMET	1	
12	6G8-42815-00-00	LEVER, CLAMP	1	
13	6G8-42831-00-00	BUSHING	1	
14	6G8-42811-00-94	STAY	1	
15	97013-06016-00	BOLT	1	
16	90386-08M49-00	BUSH	1	
17	90201-06M31-00	.WASHER, PLATE	2	
18	90387-06M72-00	COLLAR	1	
19	90206-08M13-00	WASHER, WAVE	1	
20	6G8-42748-00-00	GROMMET	1	
21	97095-06016-00	BOLT	2	
22	92995-06600-00	WASHER	2	
23	6G8-42738-00-94	PLATE, FITTING	1	
24	6G8-42719-00-94	PANEL, FRONT LOWER	1	
25	90480-19031-00	GROMMET	1	
26	90445-05ME6-00	HOSE (L8)	1	
27	97095-06016-00	BOLT	4	
28	92995-06600-00	WASHER	4	
29	6G8-42614-02-00	PANEL, FRONT UPPER	1	UR MH (MH)
29	6G8-42614-12-00	PANEL, FRONT UPPER	1	UR ER (ER)
30	6G8-42677-20-00	GRAPHIC, FRONT	1	UR ER (ER)
30	6G8-42677-00-00	GRAPHIC, FRONT	1	UR MH (MH)
31	6G8-42629-02-00	SEAL	1	
32	6G8-42755-00-00	HINGE, COWLING	1	
33	91490-16010-00	PIN. COTTER	1	
34	6G8-24379-00-00	PIPE, JOINT 4	1	
35	90445-10M78-00	HOSE (L50)	1	
36	6G8-12476-00-00	PIPE 6	1	
37	6G8-24378-01-00	PIPE, JOINT 3	1	
38	6G8-12485-00-00	PIPE 5	1	
39	90467-10M04-00	CLIP	2	
40	6E0-44191-11-00	INDICATOR, SHIFT	1	



F9.9ELRX 1999 / BRACKET 1

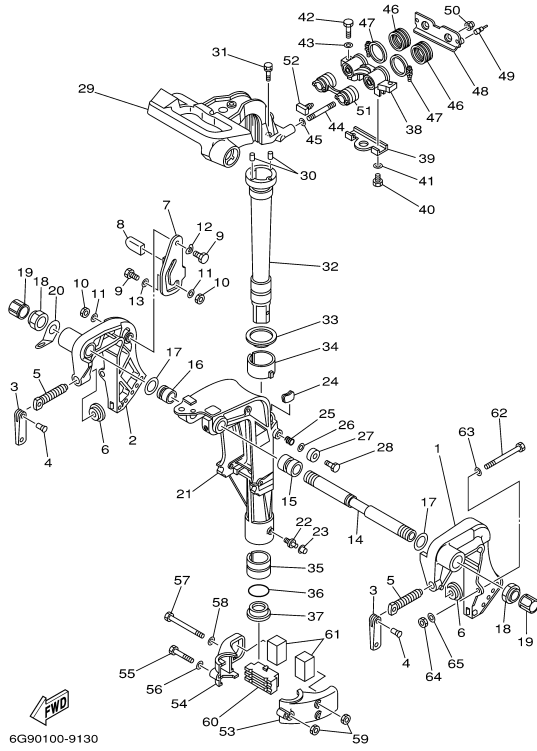

©2014 Yamaha Motor Corporation, U.S.A. All rights reserved.

## Part List

F9.9ELRX 1999 / BRACKET 1

REF - NO	PART NUMBER	PART NAME	QUANTITY	REMARKS
1	6G8-43111-04-4D	BRACKET, CLAMP 1	1	
2	6G8-43112-04-4D	BRACKET, CLAMP 2	1	
3	6E0-43118-01-00	HANDLE, TRANSOM CLAMP	2	
4	90243-04M01-00	PIN	2	
5	6E7-43116-00-00	SCREW, TRANSOM CLAMP	2	
6	648-43114-01-00	PAD, TRANSOM CLAMP	2	
7	6G8-43181-00-00	LEVER, TILT STOP	1	
8	682-43318-01-00	COVER	1	
9	90109-06M25-00	BOLT	2	
10	95680-06100-00	NUT, U	2	
11	92990-06600-00	WASHER, PLATE	2	
12	90206-10M15-00	WASHER, WAVE	1	
13	682-43339-01-00	WASHER	1	
14	6G8-43131-00-00	BOLT, CLAMP BRACKET	1	
15	90386-22M92-00	BUSH	1	
16	90386-22M93-00	BUSH	1	
17	90201-22M03-00	WASHER, PLATE	2	
18	90185-22043-00	NUT, SELF-LOCKING	2	
19	6G5-43145-00-00	CAP, CLAMP BRACKET	2	
20	6J8-43113-01-00	PLATE, CLAMP BRACKET	1	
21	6G8-43311-15-4D	BRACKET, SWIVEL 1	1	UR L
21	6G9-43311-04-4D	BRACKET, SWIVEL 1	1	UR S (MH)
22	93700-06M03-00	NIPPLE, GREASE	1	
23	663-45119-00-00	CAP, GREASE NIPPLE	1	AP
24	6G8-42528-00-00	PLATE, FRICTION	1	
25	90501-18M00-00	SPRING, COMPRESSION	1	
26	90201-06M31-00	.WASHER, PLATE	1	
27	6G8-43373-00-00	SEAL, DAMPER	1	
28	97095-06025-00	BOLT	1	
29	6G9-42511-01-4D	BRACKET, STEERING	1	
30	93605-15065-00	PIN, DOWEL	2	
31	90119-06M06-00	BOLT, WITH WASHER	2	
32	6G8-42521-10-94	SHAFT, STEERING PIVOT	1	UR L
32	6G9-42521-00-94	SHAFT, STEERING PIVOT	1	UR S (MH)
33	90209-45M09-00	WASHER	1	
34	6G8-42537-00-00	BUSHING, PIVOT SHAFT	1	
35	90386-37M47-00	BUSH	1	
36	93210-37M67-00	O-RING	1	
37	90386-37M48-00	BUSH	1	
38	6G8-44517-00-94	MOUNT RUBBER	1	
39	6G8-44526-00-00	PLATE	1	
40	97095-06012-00	BOLT	2	
41	92995-06600-00	WASHER	2	
42	97095-08030-00	BOLT	2	
43	92995-08600-00	WASHER	2	
44	90116-08M28-00	BOLT, STUD	2	
45	90201-08M12-00	.WASHER, PLATE	2	
46	6G8-44522-00-00	SEAL	2	
47	90460-38M06-00	CLAMP, HOSE	2	
48	6G8-44518-00-00	BRACKET COMP.	1	
49	6G8-44533-00-00	DAMPER, UPPER MOUNT RUBBER	2	
50	90185-08057-00	NUT, SELF-LOCKING	2	
51	6G8-44521-00-00	SEAL	1	
52	6G8-44532-00-00	STOPPER, UPPER MOUNT	1	
53	6G8-44551-01-4D	HOUSING, LOWER MOUNT RUBBER	1	
54	6G8-44552-02-4D	HOUSING, LOWER MOUNT RUBBER	1	
55	97095-06045-00	.BOLT	1	
56	92995-06600-00	WASHER	1	
57	97095-06095-00	BOLT	2	
58	92995-06600-00	WASHER	2	
59	95380-06700-00	NUT	3	
60	6G8-44557-00-00	MOUNT DAMPER, LOWER FRONT	1	
61	682-44555-00-00	MOUNT DAMPER, LOWER SIDE	2	
62	90101-08M88-00	BOLT	2	AP
63	92990-08600-00	..WASHER, PLATE	2	AP
64	95780-08300-00	..NUT, FLANGE	2	AP
65	90201-08MA4-00	WASHER, PLATE	2	AP

## Part Notes

F9.9ELRX 1999 / BRACKET 1

PART NUMBER	NOTE TEXT
92990-06600-00	OEM: This part number is among the Top 100 Most Popular Marine Maintenance Parts as of March 2014.

©2014 Yamaha Motor Corporation, U.S.A. All rights reserved.

F9.9ELRX 1999 / BRACKET 2

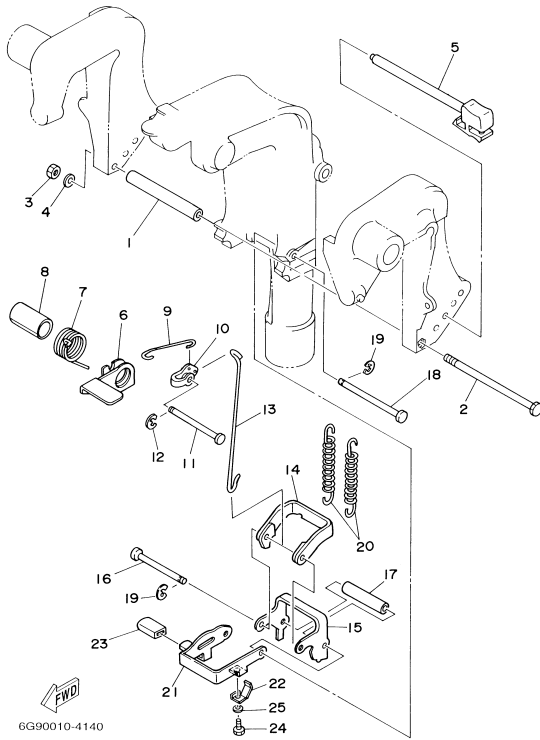

©2014 Yamaha Motor Corporation, U.S.A. All rights reserved.



## Part List

F9.9ELRX 1999 / BRACKET 2

REF - NO	PART NUMBER	PART NAME	QUANTITY	REMARKS
1	90387-06M09-00	COLLAR	1	
2	97095-06135-00	BOLT	1	
3	95380-06700-00	NUT	1	
4	92990-06600-00	WASHER, PLATE	1	
5	6G8-43160-01-00	TILT ROD ASSY	1	
6	6G8-43631-03-00	LEVER, TILT	1	
7	90508-18M33-00	SPRING, TORSION	1	
8	90386-20M94-00	BUSH	1	
9	6G8-43616-00-00	ROD, TILT LOCK	1	
10	682-43641-00-00	LEVER, TILT	1	
11	90249-06M20-00	PIN	1	
12	93430-05027-00	CIRCLIP	1	
13	6G8-43617-00-00	ROD, TILT LOCK	1	
14	682-43614-00-00	PLATE, TILT LOCK	1	
15	682-43615-01-00	PLATE, TILT LOCK	1	
16	682-43611-01-00	SHAFT, TILT LOCK	1	
17	90387-06M20-00	COLLAR	1	
18	682-43659-00-00	SHAFT, REVERSE LOCK	1	
19	93430-05027-00	CIRCLIP	2	
20	90506-26M01-00	SPRING, TENSION	2	
21	6G9-43681-00-00	LEVER, SHALLOW WATER DRIVE 1	1	
22	6G9-43643-00-00	SPRING	1	
23	682-43318-01-00	COVER	1	
24	97095-06008-00	BOLT	1	
25	92990-06600-00	WASHER, PLATE	1	

## Part Notes

F9.9ELRX 1999 / BRACKET 2

PART NUMBER	NOTE TEXT
92990-06600-00 	OEM: This part number is among the Top 100 Most Popular Marine Maintenance Parts as of March 2014.
92990-06600-00 	OEM: This part number is among the Top 100 Most Popular Marine Maintenance Parts as of March 2014.

©2014 Yamaha Motor Corporation, U.S.A. All rights reserved.

F9.9ELRX 1999 / STEERING F9.9MH

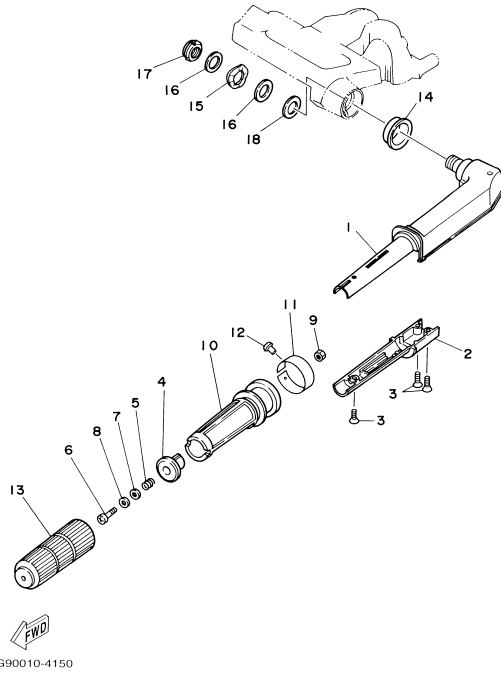

©2014 Yamaha Motor Corporation, U.S.A. All rights reserved.

## Part List

F9.9ELRX 1999 / STEERING F9.9MH

REF - NO	PART NUMBER	PART NAME	QUANTITY	REMARKS
1	6G9-42111-03-4D	HANDLE, STEERING	1	(MH)
2	6G9-42112-01-4D	HANDLE, STEERING	1	(MH)
3	98780-05016-00	.SCREW, FLAT HEAD	3	(MH)
4	6G8-42126-01-94	FRICTION, STEERING HANDLE GRIP	1	(MH)
5	90501-23M42-00	SPRING, COMPRESSION	1	(MH)
6	97880-06030-00	SCREW, PAN HEAD	1	(MH)
7	90201-06049-00	WASHER, PLATE	1	(MH)
8	90202-06007-00	WASHER, PLATE	1	(MH)
9	95380-06700-00	NUT	1	(MH)
10	6G8-42119-00-00	GRIP, STEERING HANDLE	1	(MH)
11	6G8-42137-01-00	INDICATOR, THROTTLE	1	(MH)
12	90269-02M09-00	RIVET	1	(MH)
13	6G8-42177-00-00	RUBBER, HANDLE	1	(MH)
14	90386-33M56-00	BUSH	1	(MH)
15	90206-20M14-00	WASHER, WAVE	1	(MH)
16	90201-20M00-00	WASHER, PLATE	2	(MH)
17	90185-20M03-00	NUT, SELF-LOCKING	1	(MH)
18	90202-20M33-00	WASHER, PLATE	1	(MH)

F9.9ELRX 1999 / CONTROL 1 F9.9MH

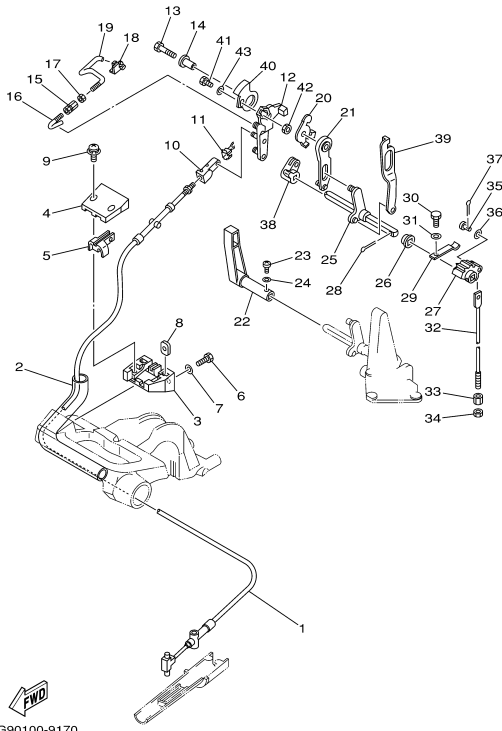

6G90100-9170

©2014 Yamaha Motor Corporation, U.S.A. All rights reserved.

Part List

F9.9ELRX 1999 / CONTROL 1 F9.9MH

REF - NO	PART NUMBER	PART NAME	QUANTITY	REMARKS
1	6G9-48311-02-00	CABLE	1	(MH)
2	90445-24M00-00	HOSE (L165)	1	(MH)
3	6G8-41661-00-98	BRACKET	1	(MH)
4	6G8-41662-00-98	BRACKET	1	(MH)
5	6G8-41663-00-00	BRACKET 3	1	(MH)
6	97095-06016-00	BOLT	2	(MH)
7	92995-06600-00	WASHER	2	(MH)
8	6G8-41654-00-00	NUT	2	(MH)
9	90159-05M06-00	SCREW, WITH WASHER	2	(MH)
10	6G8-26363-00-00	.END, WIRE 1	1	(MH)
11	6G8-26364-00-00	.END, CABLE	1	(MH)
12	6G8-41212-00-00	ARM, ACCEL.	1	(MH)
13	97013-06030-00	BOLT	1	(MH)
14	90387-06M58-00	COLLAR	1	(MH)
15	6G8-41238-01-00	JOINT, LINK	1	(MH)
16	6G8-41241-01-00	ROD, LINK	1	(MH)
17	95380-04600-00	.NUT	1	(MH)
18	6G8-41237-01-00	JOINT, LINK	1	(MH)
19	6G8-41242-01-00	ROD 2	1	(MH)
20	6G8-14493-00-00	STAY 1	1	(MH)
21	6G8-44111-00-00	HANDLE, GEAR SHIFT	1	(MH)
22	6G9-44111-00-98	HANDLE, GEAR SHIFT	1	(MH)
23	97880-04016-00	SCREW, PAN HEAD	1	(MH)
24	92990-04600-00	WASHER, PLATE	1	(MH)
25	6G8-44159-00-00	HANDLE, GEAR SHIFT	1	(MH)
26	682-44132-00-00	BUSHING	1	(MH)
27	682-44121-01-00	LEVER, SHIFT ROD	1	(MH)
28	91490-25020-00	PIN, COTTER	1	(MH)
29	682-44116-01-00	SPRING	1	(MH)
30	97095-06014-00	BOLT	1	(MH)
31	92995-06600-00	WASHER	1	(MH)
32	6G9-44143-00-00	ROD, SHIFT	1	UR S (MH)
32	6G8-44143-10-00	ROD, SHIFT	1	UR L (MH)
33	90170-06015-00	NUT	1	(MH)
34	95380-06700-00	NUT	1	(MH)
35	91790-05020-00	PIN, CLEVIS	1	(MH)
36	92990-05600-00	WASHER, PLATE	1	(MH)
37	91490-16010-00	PIN, COTTER	1	(MH)
38	6G8-44125-00-00	LEVER, SHIFT ROD	1	(MH)
39	6G8-44124-11-00	LINK, SHIFT ROD	1	(MH)
40	6G8-41212-11-00	ARM, ACCEL.	1	(MH)
41	97013-06014-00	BOLT	1	(MH)
42	95380-06600-00	NUT, HEXAGON	1	(MH)
43	92990-06600-00	WASHER, PLATE	1	(MH)

Part Notes

F9.9ELRX 1999 / CONTROL 1 F9.9MH

PART NUMBER	NOTE TEXT
92990-06600-00 	OEM: This part number is among the Top 100 Most Popular Marine Maintenance Parts as of March 2014.

©2014 Yamaha Motor Corporation, U.S.A. All rights reserved.



F9.9ELRX 1999 / CONTROL 2 F9.9ER

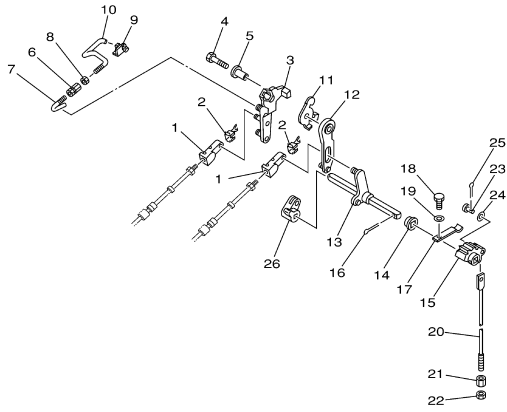

## Part List

F9.9ELRX 1999 / CONTROL 2 F9.9ER

REF - NO	PART NUMBER	PART NAME	QUANTITY	REMARKS
1	6G8-26363-00-00	.END, WIRE 1	2	(ER)
2	6G8-26364-00-00	.END, CABLE	2	(ER)
3	6G8-41212-00-00	ARM, ACCEL.	1	(ER)
4	97013-06030-00	BOLT	1	(ER)
5	90387-06M58-00	COLLAR	1	(ER)
6	6G8-41238-01-00	JOINT, LINK	1	(ER)
7	6G8-41241-01-00	ROD, LINK	1	(ER)
8	95380-04600-00	.NUT	1	(ER)
9	6G8-41237-01-00	JOINT, LINK	1	(ER)
10	6G8-41242-01-00	ROD 2	1	(ER)
11	6G8-14493-00-00	STAY 1	1	(ER)
12	6G8-44111-00-00	HANDLE, GEAR SHIFT	1	(ER)
13	6G8-44159-00-00	HANDLE, GEAR SHIFT	1	(ER)
14	682-44132-00-00	BUSHING	1	(ER)
15	682-44121-01-00	LEVER, SHIFT ROD	1	(ER)
16	91490-25020-00	PIN. COTTER	1	(ER)
17	682-44116-01-00	SPRING	1	(ER)
18	97095-06014-00	BOLT	1	(ER)
19	92995-06600-00	WASHER	1	(ER)
20	6G8-44143-10-00	ROD, SHIFT	1	L (ER)
21	90170-06015-00	NUT	1	(ER)
22	95380-06700-00	NUT	1	(ER)
23	91790-05020-00	PIN, CLEVIS	1	(ER)
24	92990-05600-00	WASHER, PLATE	1	(ER)
25	91490-16010-00	PIN. COTTER	1	(ER)
26	6G8-44125-00-00	LEVER, SHIFT ROD	1	(ER)

F9.9ELRX 1999 / REMOTE CONTROL ATTACHMENT

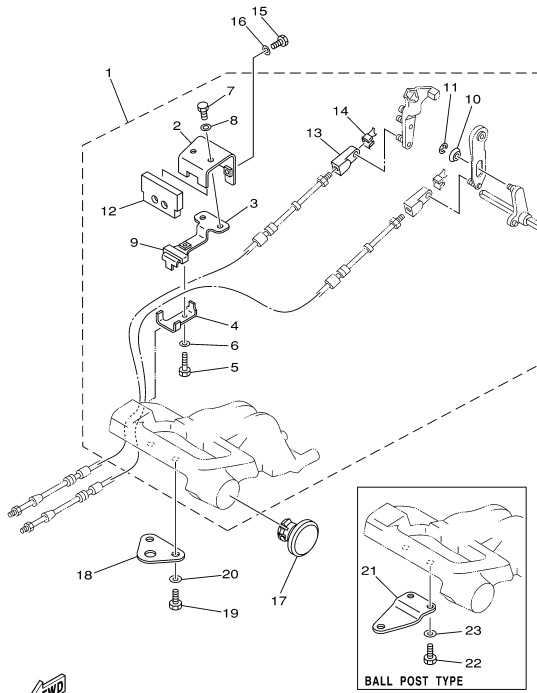

  
6G90100-9190

## Part List

F9.9ELRX 1999 / REMOTE CONTROL ATTACHMENT

REF - NO	PART NUMBER	PART NAME	QUANTITY	REMARKS
1	6G8-48501-03-00	REMOTE CONT. ATTACHMENT ASSY	1	AP ER (ER)
2	6G8-48531-51-00	.BRACKET, REMOTE CONTROL 1	1	(ER)
3	6G8-48532-50-00	.BRACKET, REMOTE CONTROL 2	1	(ER)
4	6G8-48538-50-00	.CLAMP, CABLE 1	1	(ER)
5	97095-06030-00	.BOLT	1	(ER)
6	92995-06600-00	.WASHER	1	(ER)
7	97095-06012-00	.BOLT	2	(ER)
8	92995-06600-00	.WASHER	2	(ER)
9	6G8-48565-50-00	.GROMMET	1	(ER)
10	90387-06M73-00	.COLLAR	1	(ER)
11	93430-04M03-00	.CIRCLIP	1	(ER)
12	6G8-48351-51-00	.SEAL RUBBER	1	(ER)
13	6G8-26363-00-00	.END, WIRE 1	1	(ER)
14	6G8-26364-00-00	.END, CABLE	1	(ER)
15	97095-06016-00	BOLT	2	ER (ER)
16	92995-06600-00	WASHER	2	ER (ER)
17	6G8-42551-00-00	GROMMET	1	ER (ER)
18	6G8-48511-20-00	HOOK, STEERING	1	ER STEERING GUIDE TYPE (ER)
19	97095-06016-00	BOLT	2	ER (ER)
20	92995-06600-00	WASHER	2	ER (ER)
21	6G8-48511-10-00	HOOK, STEERING	1	AP ER BALL POST TYPE (ER)
22	97095-06016-00	BOLT	2	AP ER (ER)
23	92995-06600-00	WASHER	2	AP ER (ER)

F9.9ELRX 1999 / STEERING GUIDE

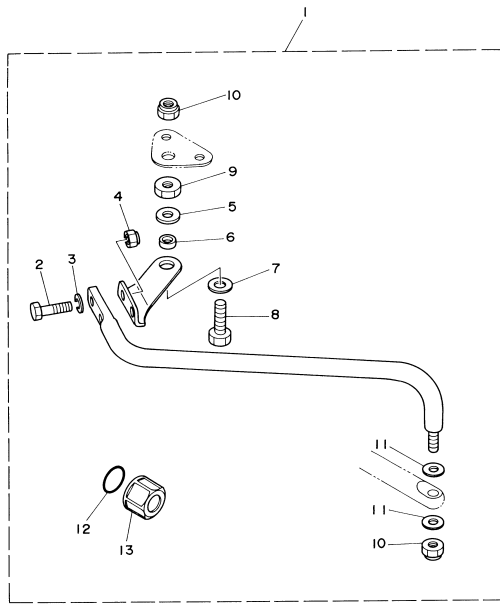

6G90100-9200

## Part List

F9.9ELRX 1999 / STEERING GUIDE

REF - NO	PART NUMBER	PART NAME	QUANTITY	REMARKS
1	6G8-61350-00-00	STEERING GUIDE ATTACHMENT KIT	1	AP ER (ER)
2	97075-08025-00	.BOLT	2	(ER)
3	92995-08600-00	.WASHER	2	(ER)
4	90185-08057-00	.NUT, SELF-LOCKING	2	(ER)
5	90201-10M04-00	.WASHER, PLATE	1	(ER)
6	90387-10M06-00	.COLLAR	1	(ER)
7	90201-10M63-00	.WASHER, PLATE	1	(ER)
8	6E5-61355-00-00	.BOLT	1	(ER)
9	90170-09M03-00	.NUT	1	(ER)
10	90185-09M01-00	.NUT, SELF-LOCKING	2	(ER)
11	90201-10M20-00	.WASHER, PLATE	2	(ER)
12	93210-16275-00	.O-RING	1	(ER)
13	6E5-43145-01-00	.CAP, CLAMP BRACKET	1	(ER)

F9.9ELRX 1999 / UPPER CASING

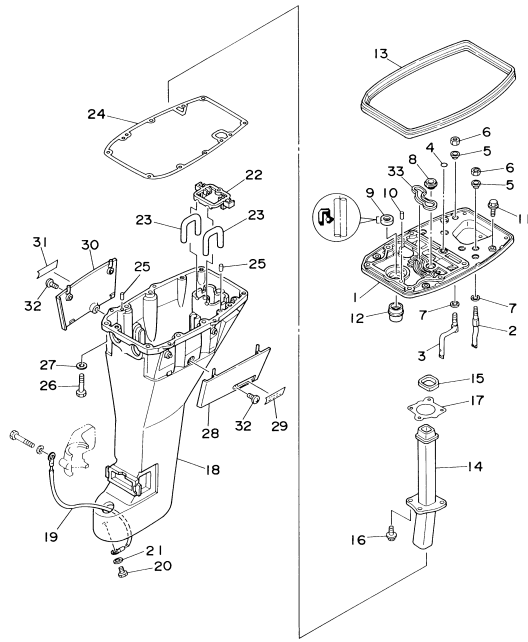

FWD  
6G90010-5230

## Part List

F9.9ELRX 1999 / UPPER CASING

REF - NO	PART NUMBER	PART NAME	QUANTITY	REMARKS
1	6G8-41137-04-94	GUIDE, EXHAUST	1	
2	6G8-12483-00-00	PIPE 3	1	
3	6G8-12484-00-00	PIPE 4	1	
4	93210-08M60-00	O-RING	1	
5	90386-10M70-00	BUSH	2	
6	95380-10700-00	NUT	2	
7	90202-10M03-00	WASHER, PLATE	2	
8	6G8-44367-00-00	DAMPER, WATER SEAL	1	
9	93101-13M27-00	O-RING	1	
10	93606-12019-00	.PIN, DOWEL	2	
11	97595-06520-00	BOLT, WITH WASHER	2	
12	6G8-45135-00-00	PIPE	1	
13	6G8-42716-00-00	RUBBER, SEAL 1	1	
14	6G8-41131-01-00	MANIFOLD, EXT. 1	1	
15	6G8-41138-00-00	SEAL, EXT. 1	1	
16	90105-06M33-00	BOLT, FLANGE	4	
17	6G8-41133-A0-00	GASKET, EXHAUST MANIFOLD 1	1	
18	6G8-45111-13-4D	CASING, UPPER	1	UR L
18	6G9-45111-03-4D	CASING, UPPER	1	UR S (MH)
19	6G8-82149-00-00	WIRE, LEAD 3	1	
20	97095-06012-00	BOLT	1	
21	92995-06600-00	WASHER	1	
22	6G8-45151-10-00	COVER, UPPER CASING	1	
23	6G8-45136-00-00	PIPE	2	
24	6G8-45113-A1-00	.GASKET, UPPER CASING	1	
25	93606-12019-00	.PIN, DOWEL	2	
26	97095-08040-00	BOLT	6	
27	92995-08600-00	WASHER	6	
28	6G8-42741-00-4D	APRON	1	
29	6G8-42791-00-00	MARK 1	1	
30	6G8-42771-00-4D	APRON	1	
31	6G8-42792-00-00	MARK	1	
32	90157-06M04-00	SCREW, PAN HEAD	2	
33	6G8-11355-00-00	SEAL, CYLINDER 1	1	



F9.9ELRX 1999 / LOWER CASING DRIVE 1

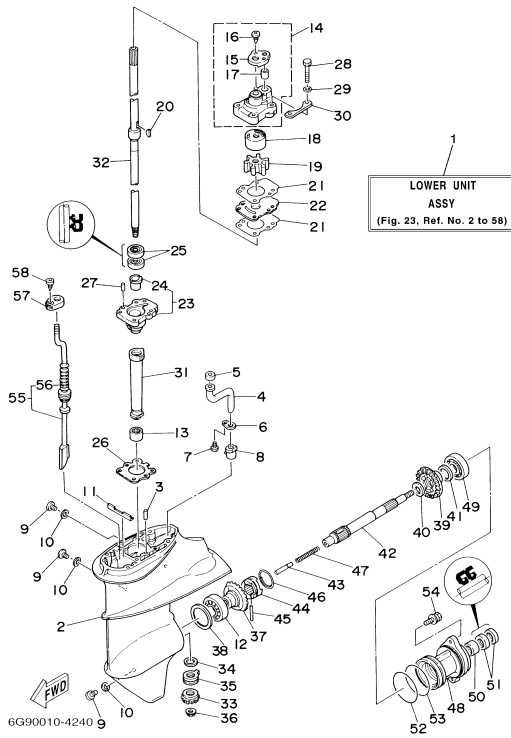

©2014 Yamaha Motor Corporation, U.S.A. All rights reserved.

## Part List

F9.9ELRX 1999 / LOWER CASING DRIVE 1

REF - NO	PART NUMBER	PART NAME	QUANTITY	REMARKS
1	6G9-45300-06-4D	LOWER UNIT ASSY	1	UR S (MH)
1	6G9-45300-16-4D	LOWER UNIT ASSY	1	UR L
2	6E8-45311-00-4D	CASING, LOWER	1	
3	93604-08062-00	PIN, DOWEL	1	
4	683-44362-01-00	TUBE, WATER	1	
5	683-44365-01-00	DAMPER, WATER SEAL	1	
6	683-44373-00-00	SET PLATE, WATER TUBE	1	
7	97095-06010-00	BOLT	1	
8	6E7-44366-00-00	DAMPER, WATER SEAL	1	
9	90340-08M04-00	PLUG, STRAIGHT SCREW	3	
10	90430-08020-00	.GASKET	3	
11	682-45376-01-00	GUIDE, SEAL DAMPER	1	
12	93332-00005-00	BEARING	1	
13	93315-314V8-00	BEARING	1	
14	682-44300-01-00	HOUSING, WATER PUMP	1	
15	682-44312-00-00	.COVER, WATER PUMP HOUSING	1	
16	97780-40112-00	.SCREW, TAPPING	2	
17	682-44365-00-00	.DAMPER, WATER SEAL	1	
18	682-44322-00-00	INSERT, CARTRIDGE	1	
19	682-44352-01-00	IMPELLER	1	
20	90280-03024-00	.KEY, WOODRUFF	1	
21	682-44315-A0-00	GASKET, WATER PUMP	2	
22	682-44323-00-00	OUTER PLATE, CARTRIDGE	1	
23	6E7-45331-00-5B	HOUSING, BEARING	1	
24	626-45316-09-00	.BUSHING, DRIVE SHAFT	1	
25	93101-20048-00	.OIL SEAL	2	
26	683-45315-A0-00	PACKING, LOWER CASING	1	
27	93606-12019-00	.PIN, DOWEL	2	
28	97095-06045-00	.BOLT	4	
29	92995-06600-00	WASHER	4	
30	682-44328-00-00	PLATE	2	
31	6E7-45536-00-00	SLEEVE, DRIVE SHAFT	1	
32	6G9-45501-01-00	DRIVE SHAFT COMP.	1	UR S (MH)
32	6G9-45501-11-00	DRIVE SHAFT COMP.	1	UR L
33	6E7-45551-00-00	PINION (13T)	1	
34	6E8-45587-00-13	SHIM (T:1.13MM)	1	UR
34	6E8-45587-00-20	SHIM (T:1.20MM)	1	UR
35	93341-414V1-00	BEARING	1	
36	90179-08M06-00	NUT	1	
37	6E7-45560-01-00	GEAR 1 (27T)	1	
38	664-45567-01-12	SHIM (T:0.12MM)	1	UR
38	664-45567-01-30	SHIM (T:0.30MM)	1	UR
38	664-45567-01-50	SHIM (T:0.50MM)	1	UR
38	664-45567-01-10	SHIM (T:0.10MM)	1	UR
38	664-45567-01-15	SHIM (T:0.15MM)	1	UR
38	664-45567-01-18	SHIM (T:0.18MM)	1	UR
38	664-45567-01-40	SHIM (T:0.40MM)	1	UR
39	6E7-45571-00-00	GEAR 2 (27T)	1	
40	90201-17682-00	WASHER, PLATE	1	
41	626-45577-00-01	SHIM (T:0.10MM)	1	UR
41	626-45577-00-03	SHIM (T:0.30MM)	1	UR
41	626-45577-00-05	SHIM (T:0.50MM)	1	UR
42	683-45611-00-00	SHAFT, PROPELLER	1	
43	650-45635-00-00	PLUNGER, SHIFT	1	
44	682-45631-00-00	CLUTCH, DOG	1	
45	90250-05010-00	PIN, STRAIGHT	1	
46	648-45633-00-00	RING, CROSS PIN	1	
47	90501-14M06-00	SPRING, COMPRESSION	1	
48	683-45361-02-4D	CAP, LOWER CASING	1	
49	93306-00501-00	BEARING	1	
50	93315-317U2-00	BEARING	1	
51	93101-17054-00	.OIL SEAL	2	
52	93210-57M09-00	.O-RING	1	
53	93210-56M80-00	.O-RING	1	
54	97595-06520-00	BOLT, WITH WASHER	2	
55	6G9-44150-00-00	SHIFT CAM ASSY.	1	UR S (MH)
55	6G9-44150-10-00	SHIFT CAM ASSY.	1	UR L
56	682-44147-00-00	.BOOT, SHIFT ROD	1	
57	682-44176-00-00	BRACKET	1	
58	97780-50510-00	SCREW, TAPPING	1	

## Part Notes

F9.9ELRX 1999 / LOWER CASING DRIVE 1

PART NUMBER	NOTE TEXT
90430-08020-00 	OEM: This part number is among the Top 100 Most Popular Marine Maintenance Parts as of March 2014.

©2014 Yamaha Motor Corporation, U.S.A. All rights reserved.

F9.9ELRX 1999 / LOWER CASING DRIVE 2

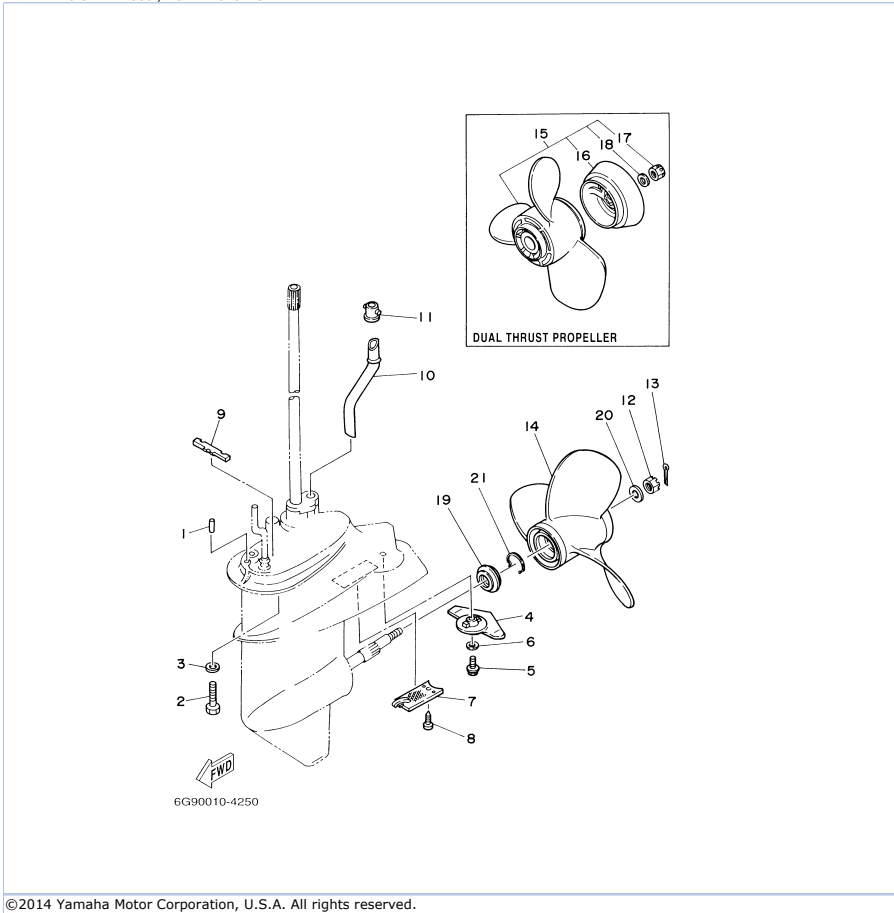

## Part List

F9.9ELRX 1999 / LOWER CASING DRIVE 2

REF - NO	PART NUMBER	PART NAME	QUANTITY	REMARKS
1	93606-12019-00	.PIN, DOWEL	2	
2	97075-08035-00	BOLT	4	
3	92995-08600-00	WASHER	4	
4	6E8-45251-02-00	ANODE	1	
5	95895-06020-00	BOLT, FLANGE	1	
6	92990-06300-00	WASHER, INTERNAL TOOTH	1	
7	6E7-45214-00-00	COVER, WATER INLET 1	1	
8	97880-05012-00	SCREW, PAN HEAD	1	
9	682-45375-01-00	DAMPER, SEAL	1	
10	6G9-44361-00-00	TUBE, WATER	1	UR S (MH)
10	6G8-44361-10-00	TUBE, WATER	1	UR L
11	626-44365-01-00	DAMPER, WATER SEAL	1	
12	90171-10M01-00	NUT, CASTLE	1	
13	91490-30020-00	PIN. COTTER	1	
14	683-45941-00-EL	PROPELLER (3X9-1/4"X12"-J)	1	UR
14	683-45949-00-EL	PROPELLER (3X9-1/2"X6-1/2"-J)	1	UR
14	63V-45947-00-EL	PROPELLER (3X9-1/4"X8"-J)	1	UR
14	683-45943-00-EL	PROPELLER (3X9-1/4"X10-1/2"-J)	1	UR
14	683-45945-00-EL	PROPELLER (3X9-1/4"X9"-J)	1	UR
14	683-45947-00-EL	PROPELLER (3X9-1/4"X8"-J)	1	UR
14	683-45952-00-EL	PROPELLER (3X9-1/4"X9-3/4"-J)	1	UR
15	683-W4592-02-EL	PROPELLER (3X9-3/4"X6-1/2"-J)	1	UR DUAL THRUST PROP.
15	683-W4591-02-EL	PROPELLER (3X9-3/4"X8"-J)	1	UR DUAL THRUST PROP.
16	6E7-45986-00-00	.RING, DEFLECTOR	1	
17	90171-10M07-00	.NUT, CASTLE	1	
18	90201-10M02-00	.WASHER, PLATE	1	
19	6G9-45987-00-00	SPACER	1	
20	90201-10M01-00	WASHER, PLATE	1	
21	93450-10M05-00	CIRCLIP	1	

F9.9ELRX 1999 / GENERATOR

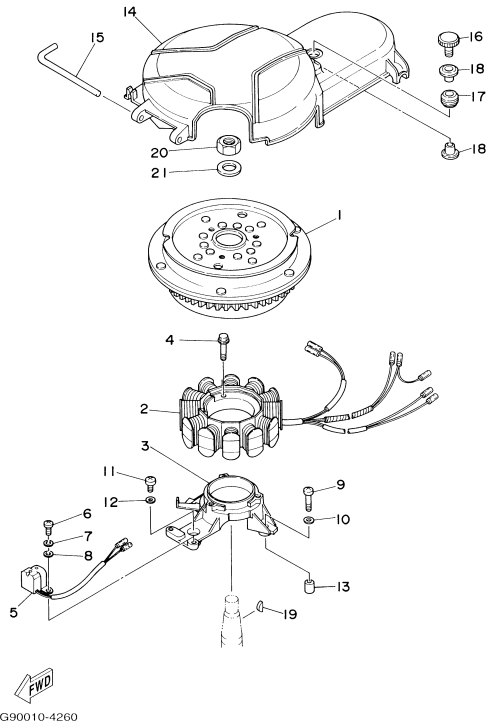

6G90010-4260



Part List

F9.9ELRX 1999 / GENERATOR

REF - NO	PART NUMBER	PART NAME	QUANTITY	REMARKS
1	6G8-85550-11-00	ROTOR ASSY	1	UR MH (MH)
1	6G8-85550-01-00	ROTOR ASSY	1	UR ER (ER)
2	6G9-85510-01-00	STATOR ASSY	1	
3	6G8-85561-00-94	BASE, MAGNETO	1	
4	95023-06025-00	BOLT	3	
5	6G8-85580-02-00	COIL, PULSER	1	
6	97880-05012-00	SCREW, PAN HEAD	2	
7	92990-05100-00	.WASHER, SPRING	2	
8	92990-05600-00	WASHER, PLATE	2	
9	97880-06025-00	SCREW, PAN HEAD	2	
10	92990-06600-00	WASHER, PLATE	2	
11	97880-06020-00	SCREW, PAN HEAD	1	
12	92990-06600-00	WASHER, PLATE	1	
13	99530-08012-00	PIN, DOWEL	2	
14	6G8-81337-01-00	COVER, FLYWHEEL	1	
15	6G8-42752-00-00	SHAFT	1	
16	6G8-81323-00-00	SCREW 1	1	
17	90480-15M31-00	GROMMET	1	
18	90387-06M71-00	COLLAR	2	
19	90280-05013-00	KEY, WOODRUFF	1	
20	90170-12066-00	NUT	1	
21	90201-12472-00	WASHER, PLATE	1	

Part Notes

F9.9ELRX 1999 / GENERATOR

PART NUMBER	NOTE TEXT
92990-06600-00 	OEM: This part number is among the Top 100 Most Popular Marine Maintenance Parts as of March 2014.
92990-06600-00 	OEM: This part number is among the Top 100 Most Popular Marine Maintenance Parts as of March 2014.

©2014 Yamaha Motor Corporation, U.S.A. All rights reserved.

F9.9ELRX 1999 / STARTING MOTOR F9.9ER

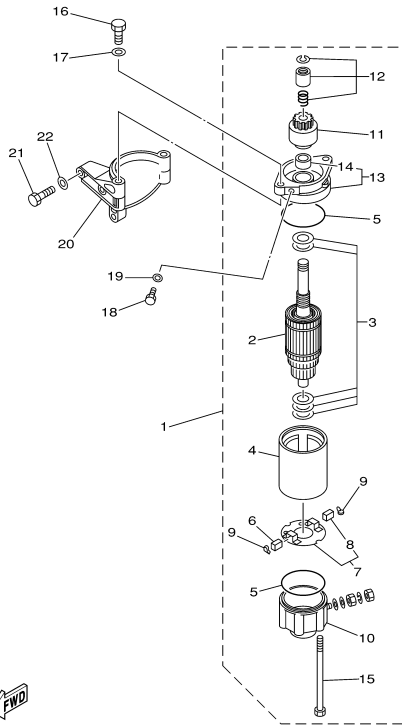

## Part List

F9.9ELRX 1999 / STARTING MOTOR F9.9ER

REF - NO	PART NUMBER	PART NAME	QUANTITY	REMARKS
1	6G8-81800-11-00	STARTING MOTOR ASSY	1	(ER)
2	689-81850-12-00	.ARMATURE ASSY	1	(ER)
3	689-81809-11-00	.WASHER KIT	1	(ER)
4	689-81810-11-00	.STATOR ASSY	1	(ER)
5	689-81847-11-00	.O-RING	2	(ER)
6	689-81811-11-00	.BRUSH 1	1	(ER)
7	689-81840-11-00	.BRUSH HOLDER ASSY	1	(ER)
8	689-81812-11-00	..BRUSH 2	1	(ER)
9	689-81813-10-00	.SPRING, BRUSH	2	(ER)
10	689-81820-11-00	.REAR BRACKET ASSY	1	(ER)
11	689-81807-12-00	.GEAR ASSY, STARTING MOTOR	1	(ER)
12	689-81857-11-00	.PINION STOPPER SET	1	(ER)
13	6F5-81830-11-00	.FRONT BRACKET ASSY	1	(ER)
14	689-81831-00-00	..METAL, FRONT	1	(ER)
15	689-81826-10-00	.BOLT	2	(ER)
16	97075-08025-00	BOLT	2	(ER)
17	92995-08600-00	WASHER	2	(ER)
18	97095-08016-00	BOLT	1	(ER)
19	92995-08600-00	WASHER	1	(ER)
20	6G8-81822-40-94	BRACKET, STARTING MOTOR	1	(ER)
21	97013-08030-00	BOLT	3	(ER)
22	92903-08600-00	WASHER, PLATE	3	(ER)



F9.9ELRX 1999 / ELECTRICAL 1

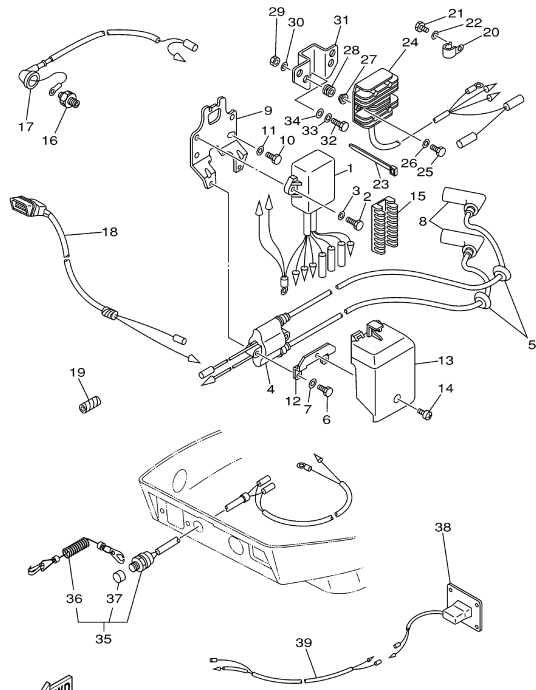

6G90110-9270

©2014 Yamaha Motor Corporation, U.S.A. All rights reserved.



Part List

F9.9ELRX 1999 / ELECTRICAL 1

REF - NO	PART NUMBER	PART NAME	QUANTITY	REMARKS
1	6G9-85540-22-00	C.D.I. UNIT ASSY	1	
2	97095-06020-00	BOLT	2	
3	92995-06600-00	WASHER	2	
4	6G8-85570-21-00	IGNITION COIL ASSY	1	
5	90480-25161-00	GROMMET	2	
6	97095-06025-00	BOLT	2	
7	92995-06600-00	WASHER	2	
8	6G8-82370-30-00	PLUG CAP ASSY	2	
9	6G8-85542-00-00	BRACKET	1	
10	97095-06020-00	BOLT	2	
11	92995-06600-00	WASHER	2	
12	6G8-85525-00-00	PLATE	1	
13	6G8-81916-00-00	COVER, TERMINAL	1	
14	98980-06008-00	SCREW, BIND	1	
15	6G8-82522-00-00	CLAMP, COUPLER	1	
16	6G8-82504-00-00	OIL PRESSURE SWITCH ASSY	1	
17	6G8-82127-00-00	WIRE, LEAD 2	1	
18	6G8-83582-01-00	PILOT LIGHT ASSY	1	MH (MH)
19	90446-10M02-00	HOSE	1	
20	90465-08M75-00	CLAMP	1	
21	97013-06012-00	BOLT	1	
22	92903-06600-00	WASHER, PLATE	1	
23	90465-13M11-00	CLAMP	1	
24	6G8-81960-A1-00	RECTIFIER ASSY	1	ER (ER)
25	97095-06025-00	BOLT	2	ER (ER)
26	92995-06600-00	WASHER	2	ER (ER)
27	90387-06M70-00	COLLAR	2	ER (ER)
28	90480-13M24-00	GROMMET	2	ER (ER)
29	95380-06700-00	NUT	2	ER (ER)
30	92990-06600-00	WASHER, PLATE	2	ER (ER)
31	6G8-81948-02-00	BRACKET	1	ER (ER)
32	97095-06020-00	BOLT	1	ER (ER)
33	92995-06100-00	WASHER, SPRING	1	ER (ER)
34	92995-06600-00	WASHER	1	ER (ER)
35	6G9-82575-02-00	ENGINE STOP SWITCH ASSY	1	MH (MH)
36	682-82556-00-00	.LANYARD, STOP SWITCH	1	(MH)
37	689-8257Y-00-00	.CAP	1	(MH)
38	6G8-83530-00-00	PILOT LIGHT ASSY	1	ER (ER)
39	6G8-82541-00-00	WIRE, LEAD	1	ER (ER)

Part Notes

F9.9ELRX 1999 / ELECTRICAL 1

PART NUMBER	NOTE TEXT
92990-06600-00 	OEM: This part number is among the Top 100 Most Popular Marine Maintenance Parts as of March 2014.
682-82556-00-00 	OEM: This part number is among the Top 100 Most Popular Marine Maintenance Parts as of March 2014.

©2014 Yamaha Motor Corporation, U.S.A. All rights reserved.

F9.9ELRX 1999 / ELECTRICAL 2 F9.9ER

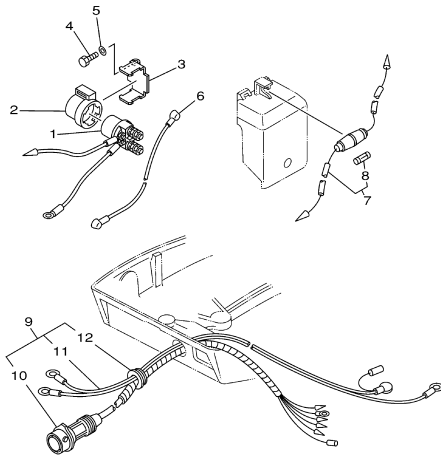

  
6G90110-9280

## Part List

F9.9ELRX 1999 / ELECTRICAL 2 F9.9ER

REF - NO	PART NUMBER	PART NAME	QUANTITY	REMARKS
1	6J0-81941-10-00	STARTER RELY ASSY	1	(ER)
2	6G1-81952-00-00	HOLDER, RELAY	1	(ER)
3	6G8-81953-00-00	STAY, RELAY	1	(ER)
4	97095-06012-00	BOLT	1	(ER)
5	92995-06600-00	WASHER	1	(ER)
6	6G8-82117-00-00	WIRE, LEAD	1	(ER)
7	6G8-82150-00-00	FUSE HOLDER ASSY	1	(ER)
8	663-82151-00-00	.FUSE (12V-20A)	1	(ER)
9	6G8-82580-00-00	WIRE HARNESS ASSY 2	1	(ER)
10	6G8-82590-00-00	.WIRE HARNESS ASSY	1	(ER)
11	6G8-82105-01-00	.BATTERY CABLE	1	(ER)
12	6G8-42724-50-00	.GROMMET	1	(ER)

F9.9ELRX 1999 / OPTIONAL PARTS

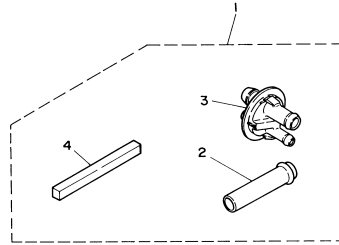

6G80100-9310

©2014 Yamaha Motor Corporation, U.S.A. All rights reserved.

## Part List

F9.9ELRX 1999 / OPTIONAL PARTS

REF - NO	PART NUMBER	PART NAME	QUANTITY	REMARKS
1	6G8-W4537-00-00	WELL-TYPE EXHAUST KIT	1	AP (ER)
2	6G8-14611-00-00	.PIPE, EXHAUST 1	1	(ER)
3	6G8-44391-10-00	.NIPPLE, HOSE	1	(ER)
4	6G8-45375-10-00	.DAMPER, SEAL	1	(ER)

F9.9ELRX 1999 / REPAIR KIT 1

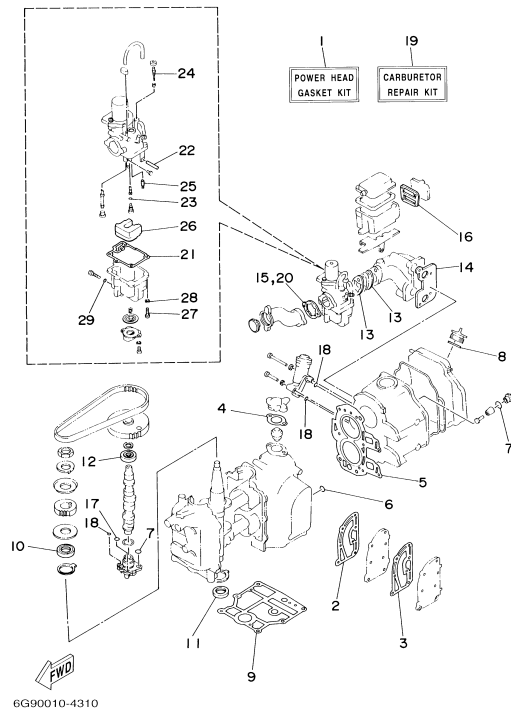

©2014 Yamaha Motor Corporation, U.S.A. All rights reserved.

## Part List

F9.9ELRX 1999 / REPAIR KIT 1

REF - NO	PART NUMBER	PART NAME	QUANTITY	REMARKS
1	6G8-W0001-A3-00	POWER HEAD GASKET KIT	1	
2	6G8-41112-02-00	.GASKET, EXHAUST INNER COVER	1	
3	6G8-41114-00-00	.GASKET, EXHAUST OUTER COVER	1	
4	6G8-12414-A0-00	.GASKET, COVER	1	
5	6G8-11181-A1-00	.GASKET, CYLINDER HEAD 1	1	
6	93210-11M59-00	.O-RING	1	
7	93210-13M63-00	.O-RING	3	
8	93210-24M79-00	.O-RING	1	
9	6G8-11351-A0-00	.GASKET, CYLINDER	1	
10	93102-30M22-00	.OIL SEAL	1	
11	93101-25M24-00	.OIL SEAL	1	
12	93102-18M21-00	.OIL SEAL	1	
13	6G8-13646-A0-00	.GASKET, MANIFOLD 2	2	
14	6G8-13645-00-00	.GASKET, MANIFOLD 1	1	
15	6G8-14198-A0-00	.GASKET	1	
16	6G8-15374-00-00	.GASKET, BREATHER	1	
17	93210-10M61-00	.O-RING	1	
18	93210-09M01-00	.O-RING	3	
19	6G8-W0093-03-00	CARBURETOR REPAIR KIT	1	
20	6G8-14198-A0-00	.GASKET	1	
21	6G8-14384-01-00	.GASKET, FLOAT CHAMBER	1	
22	647-14386-00-00	.PIN, FLOAT	1	
23	654-14198-00-00	.GASKET	1	
24	6G8-14323-00-00	.SCREW, AIR ADJUSTING	1	
25	6G8-14392-00-00	.VALVE, NEEDLE	1	
26	6G8-14385-00-00	.FLOAT	1	
27	98580-04014-00	.SCREW, PAN HEAD	1	
28	92903-04100-00	.WASHER	1	
29	5Y1-14397-00-00	.O-RING	1	



F9.9ELRX 1999 / REPAIR KIT 2

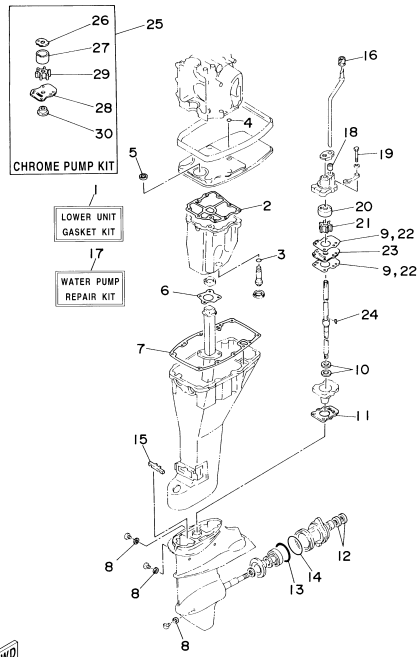

FWD  
6G90010-4320

©2014 Yamaha Motor Corporation, U.S.A. All rights reserved.

## Part List

F9.9ELRX 1999 / REPAIR KIT 2

REF - NO	PART NUMBER	PART NAME	QUANTITY	REMARKS
1	6G9-W0001-C6-00	LOWER UNIT GASKET KIT	1	
2	6G8-15312-A1-00	.GASKET, OIL PAN	1	
3	93210-16M64-00	.O-RING	1	
4	93210-08M60-00	.O-RING	1	
5	93101-13M27-00	.O-RING	1	
6	6G8-41133-A0-00	.GASKET, EXHAUST MANIFOLD 1	1	
7	6G8-45113-A1-00	.GASKET, UPPER CASING	1	
8	90430-08020-00	.GASKET	3	
9	682-44315-A0-00	.GASKET, WATER PUMP	2	
10	93101-20048-00	.OIL SEAL	2	
11	683-45315-A0-00	.PACKING, LOWER CASING	1	
12	93101-17054-00	.OIL SEAL	2	
13	93210-57M09-00	.O-RING	1	
14	93210-56M80-00	.O-RING	1	
15	682-45375-01-00	.DAMPER, SEAL	1	
16	626-44365-01-00	.DAMPER, WATER SEAL	1	
17	682-W0078-A2-00	WATER PUMP REPAIR KIT	1	
18	682-44365-00-00	.DAMPER, WATER SEAL	1	
19	97095-06045-00	.BOLT	4	
20	682-44322-00-00	.INSERT, CARTRIDGE	1	
21	682-44352-01-00	.IMPELLER	1	
22	682-44315-A0-00	.GASKET, WATER PUMP	2	
23	682-44323-00-00	.OUTER PLATE, CARTRIDGE	1	
24	90280-03024-00	.KEY, WOODRUFF	1	
25	682-W0078-0A-00	CHROME PUMP KIT	1	
26	682-44321-40-00	.INNER PLATE, CARTRIDGE	1	
27	682-44322-40-00	.INSERT, CARTRIDGE	1	
28	682-44323-40-00	.OUTER PLATE, CARTRIDGE	1	
29	682-44352-01-00	.IMPELLER	1	
30	682-45344-00-00	.COVER, OIL SEAL	1	

## Part Notes

F9.9ELRX 1999 / REPAIR KIT 2

PART NUMBER	NOTE TEXT
90430-08020-00 	OEM: This part number is among the Top 100 Most Popular Marine Maintenance Parts as of March 2014.

©2014 Yamaha Motor Corporation, U.S.A. All rights reserved.

*F9.9ELRX 1999 / MODELS IN THIS CATALOG*

F9.9MSHX	(6G9)	Engine Serial No.(MSHX): 6G9S-0011142	and following
F9.9MLHX	(6G9)	Engine Serial No.(MLHX): 6G9L-0308537	and following
F9.9ELRX	(6G9)	Engine Serial No.(ELRX): 6G9L-0402190	and following

**ALL THESE MODELS USE THIS SAME PARTS CATALOG.  
BE SURE TO ORDER ONLY THOSE PARTS APPLICABLE  
TO THE DESIRED MODEL.**

©2014 Yamaha Motor Corporation, U.S.A. All rights reserved.