

F8MSHC 2004 / TOP COWLING

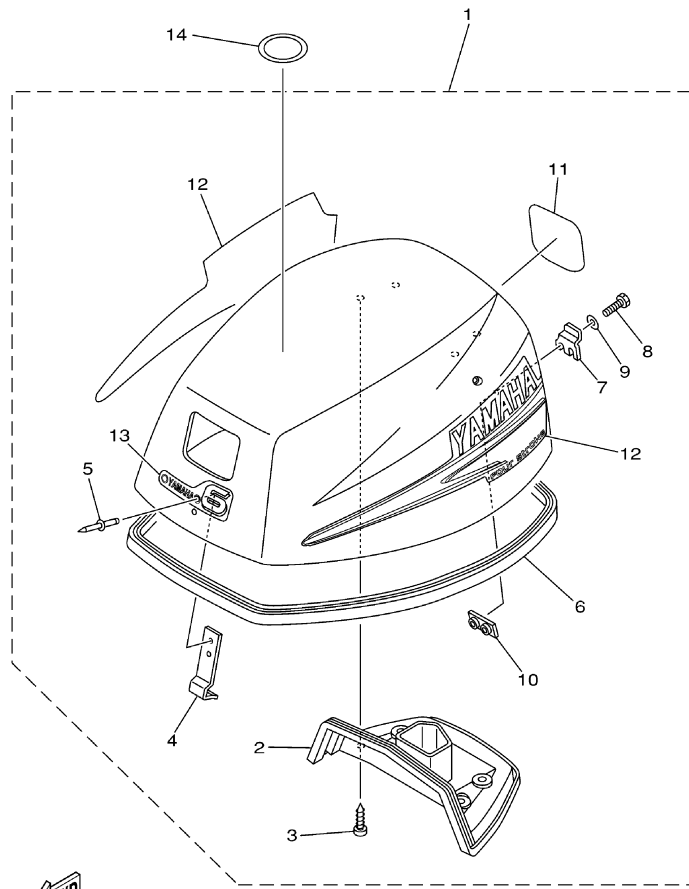

 68R1100-2010

Part List

F8MSHC 2004 / TOP COWLING

REF - NO	PART NUMBER	PART NAME	QUANTITY	REMARKS
1	68T-42610-20-4D	TOP COWLING ASSY	1	UR F8
2	68T-42613-00-00	.MOLDING, AIR DUCT	1	
3	97780-60516-00	.SCREW, TAPPING	4	
4	6G1-42651-02-00	.HOOK	1	
5	90266-04M04-00	.RIVET	2	
6	68T-42615-00-00	.SEAL	1	
7	68T-42652-00-00	.HOOK	1	
8	97095-05016-00	.BOLT	2	
9	92995-05600-00	.WASHER	2	
10	68T-42649-00-00	.HOLDER, CLAMP BAND	1	
11	68T-42678-20-00	.GRAPHIC, REAR	1	UR F8
12	68T-W0070-20-00	.GRAPHIC SET	1	
13	68T-42677-00-00	.GRAPHIC, FRONT	1	UR F8
14	67F-13434-02-00	LABEL, CAUTION	1	

F8MSHC 2004 / CYLINDER CRANKCASE 1

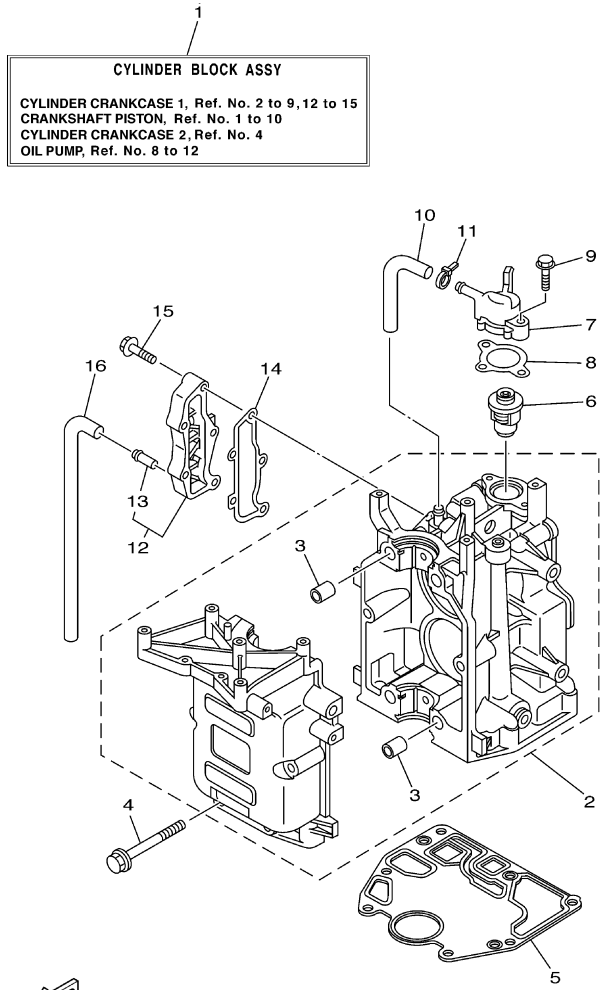

CYLINDER BLOCK ASSY
CYLINDER CRANKCASE 1, Ref. No. 2 to 9, 12 to 15
CRANKSHAFT PISTON, Ref. No. 1 to 10
CYLINDER CRANKCASE 2, Ref. No. 4
OIL PUMP, Ref. No. 8 to 12



68R2100-3020

Part List

F8MSHC 2004 / CYLINDER CRANKCASE 1

REF - NO	PART NUMBER	PART NAME	QUANTITY	REMARKS
1	68T-W009B-10-1S	CYLINDER BLOCK ASSY	1	
2	68T-15100-10-1S	CRANKCASE ASSY	1	
3	99530-12016-00	.PIN, DOWEL	4	
4	90119-08M29-00	BOLT, WITH WASHER	6	
5	68T-11351-00-00	.GASKET, CYLINDER	1	
6	66M-12411-00-00	THERMOSTAT	1	
7	68T-12413-00-1S	COVER, THERMOSTAT	1	
8	6G8-12414-A0-00	.GASKET, COVER	1	
9	90119-06MA2-00	BOLT, WITH WASHER	2	
10	68T-12481-00-00	PIPE 1	1	
11	90465-11M10-00	CLAMP	1	
12	68T-41113-00-1S	OUTER COVER, EXHAUST	1	
13	6E9-24378-00-00	.PIPE, JOINT 3	1	
14	68T-41114-A0-00	.GASKET, EXHAUST OUTER COVER	1	
15	90119-06MA3-00	BOLT, WITH WASHER	5	
16	68T-12482-00-00	PIPE 2	1	

F8MSHC 2004 / CRANKSHAFT PISTON

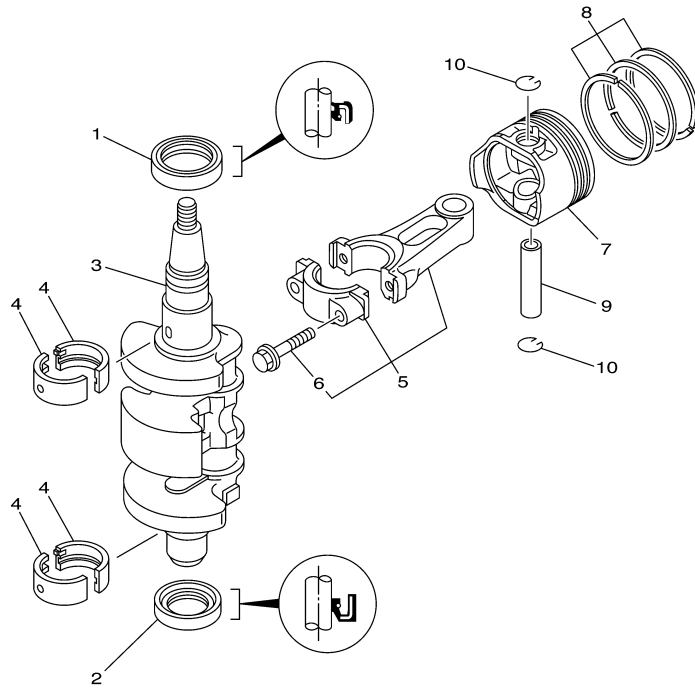

68R0010-0031

Part List

F8MSHC 2004 / CRANKSHAFT PISTON

REF - NO	PART NUMBER	PART NAME	QUANTITY	REMARKS
1	93102-30M22-00	.OIL SEAL	1	
2	93101-25M69-00	.OIL SEAL	1	
3	68T-11411-00-00	CRANKSHAFT	1	
4	68T-11416-00-00	PLANE BEARING, CRANKSHAFT 1	4	UR BROWN
4	68T-11416-20-00	PLANE BEARING, CRANKSHAFT 1	4	UR BLUE
4	68T-11416-10-00	PLANE BEARING, CRANKSHAFT 1	4	UR BLACK
5	68T-11650-00-00	CONNECTING ROD ASSY	2	
6	67D-11654-00-00	.BOLT, CONNECTING ROD	2	
7	68T-11631-00-96	PISTON (STD)	2	
7	68T-11636-00-00	PISTON (0.50MM O/S)	2	AP
7	68T-11635-00-00	PISTON (0.25MM O/S)	2	AP
8	68T-11603-01-00	PISTON RING SET (STD)	2	
8	68T-11605-01-00	PISTON RING SET (0.50MM O/S)	2	AP
8	68T-11604-01-00	PISTON RING SET (0.25MM O/S)	2	AP
9	68T-11633-00-00	PIN, PISTON	2	
10	93450-15023-00	CIRCLIP	4	

F8MSHC 2004 / CYLINDER CRANKCASE 2

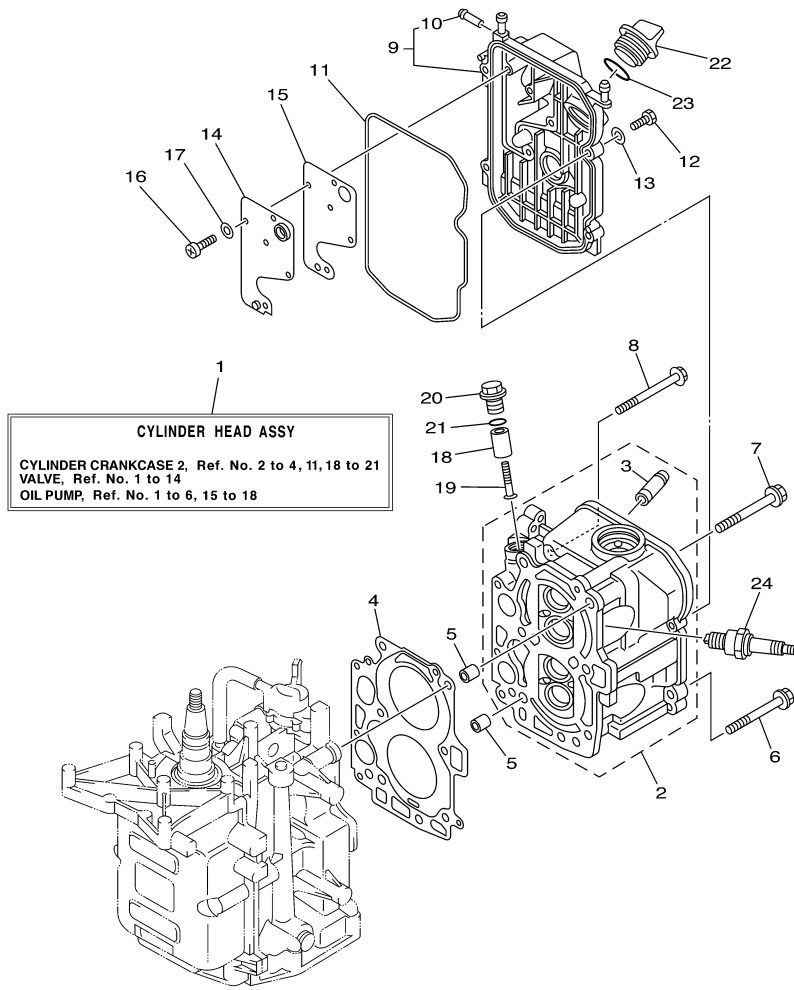



68R2100-3040

Part List

F8MSHC 2004 / CYLINDER CRANKCASE 2

REF - NO	PART NUMBER	PART NAME	QUANTITY	REMARKS
1	68T-W009A-02-1S	CYLINDER HEAD ASSY	1	
2	68T-11111-01-1S	HEAD, CYLINDER 1	1	
3	67D-11133-10-00	.GUIDE, VALVE 1	4	
4	68T-11181-00-00	.GASKET, CYLINDER HEAD 1	1	
5	99510-10114-00	PIN, DOWEL	2	
6	90105-08M36-00	BOLT, FLANGE	2	
7	90105-08M78-00	BOLT, FLANGE	4	
8	90119-06049-00	BOLT, WITH WASHER	3	
9	68T-11191-00-1S	COVER, CYLINDER HEAD 1	1	
10	650-24378-00-00	.PIPE, JOINT 4	1	
11	68T-11356-00-00	.SEAL, CYLINDER 2	1	
12	97095-06020-00	BOLT	4	
13	92995-06600-00	WASHER	4	
14	68T-11168-00-00	COVER, BREATHER	1	
15	68T-11169-A0-00	.GASKET, BREATHER COVER	1	
16	98507-04010-00	SCREW, PAN HEAD	5	
17	92907-04600-00	WASHER	5	
18	6G8-11325-00-00	ANODE	1	
19	97880-05025-00	SCREW, PAN HEAD	1	
20	6G8-11197-01-00	PLUG, BLIND	1	
21	93210-13M63-00	.O-RING	1	
22	6G8-15363-00-00	PLUG, OIL	1	
23	93210-24M79-00	.O-RING	1	
24	94702-00274-00	PLUG, SPARK (NGK BR6HS-10)	2	

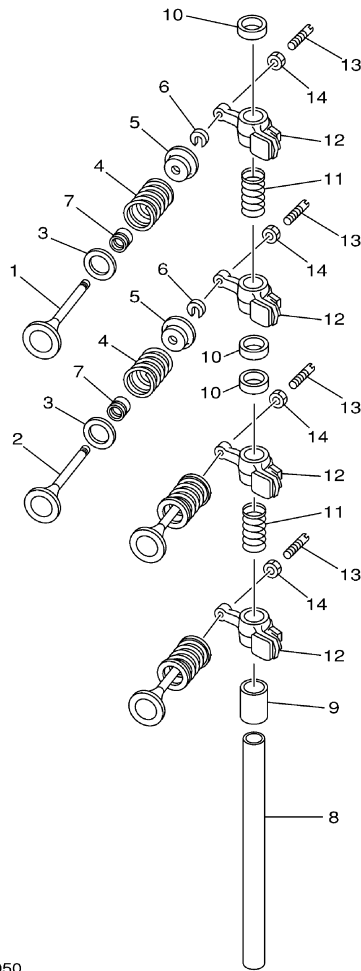
F8MSHC 2004 / VALVE



68R0010-0050

Part List

F8MSHC 2004 / VALVE

REF - NO	PART NUMBER	PART NAME	QUANTITY	REMARKS
1	67D-12111-00-00	VALVE, INTAKE	2	
2	67D-12121-00-00	VALVE, EXHAUST	2	
3	68T-12116-00-00	SEAT, VALVE SPRING	4	
4	68T-12113-00-00	SPRING, VALVE INNER	4	
5	7NJ-12117-00-00	RETAINER, VALVE SPRING	4	
6	7NJ-12118-00-00	LOCK, VALVE SPRING RETAINER	4	
7	51Y-12119-00-00	SEAL, VALVE STEM	4	
8	68T-12146-00-00	SHAFT, ROCKER	1	
9	90387-13M56-00	COLLAR	1	
10	90387-14M03-00	COLLAR	3	
11	90501-12M40-00	SPRING, COMPRESSION	2	
12	68T-12151-00-00	ARM, VALVE ROCKER	4	
13	6G8-12159-00-00	SCREW, VALVE ADJUSTING	4	
14	6G8-12158-00-00	NUT, LOCK	4	

F8MSHC 2004 / INTAKE

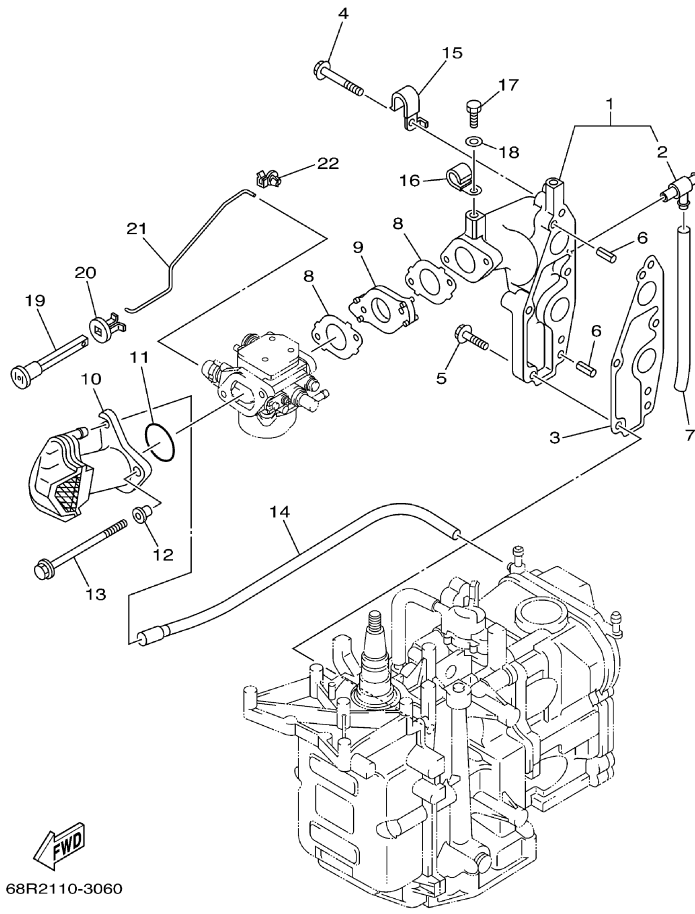

Part List

F8MSHC 2004 / INTAKE

REF - NO	PART NUMBER	PART NAME	QUANTITY	REMARKS
1	68T-13641-20-1S	MANIFOLD, INTAKE 1	1	FLUSHING KIT
2	67F-12482-00-00	.PIPE 2	1	
3	68T-13645-00-00	.GASKET, MANIFOLD 1	1	
4	90119-06MA5-00	BOLT, WITH WASHER	3	
5	90119-06MA3-00	BOLT, WITH WASHER	2	
6	91690-50014-00	PIN, SPRING	2	
7	90445-09M20-00	HOSE (L95)	1	FLUSHING KIT
8	68T-13646-A0-00	.GASKET, MANIFOLD 2	2	
9	68T-14271-00-00	INSULATOR	1	
10	68T-14440-00-00	SILENCER ASSY, INTAKE	1	
11	93210-31MJ5-00	.O-RING	1	
12	90387-06M70-00	COLLAR	2	
13	97595-06585-00	BOLT, WITH WASHER	2	
14	68T-12483-00-00	PIPE 3	1	
15	90465-08M99-00	CLAMP	1	
16	90465-08M83-00	CLAMP	1	FLUSHING KIT
17	97095-06010-00	BOLT	1	FLUSHING KIT
18	92995-06600-00	WASHER	1	FLUSHING KIT
19	6H4-41271-01-00	KNOB, CHOKE	1	
20	689-41273-00-00	GROMMET	1	
21	68T-41256-00-00	ROD, CHOKE 1	1	
22	6J8-41262-00-00	JOINT, CHOKE LEVER	1	

F8MSHC 2004 / CARBURETOR

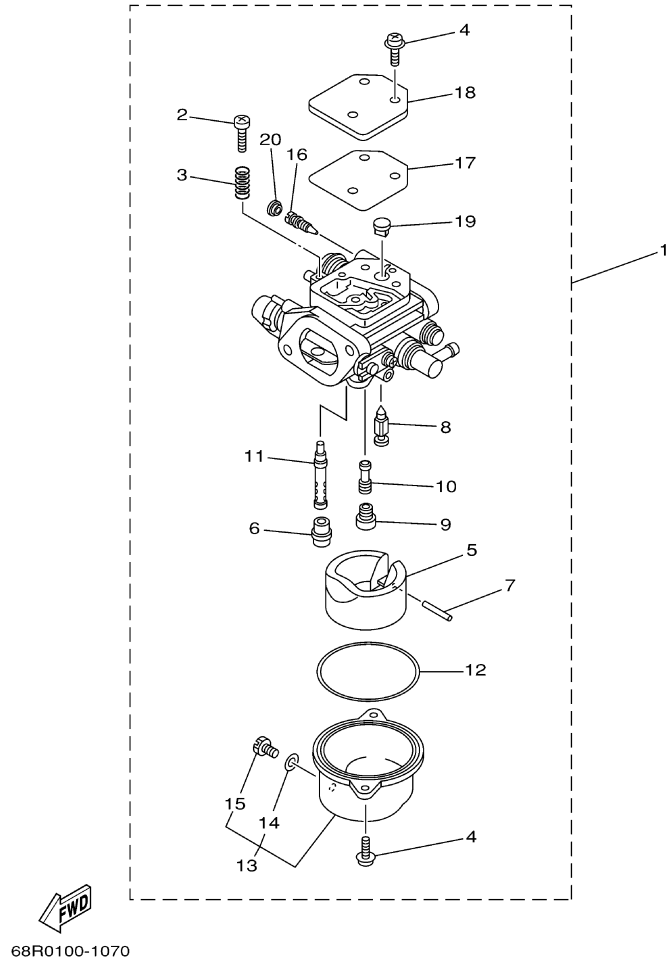

Part List

F8MSHC 2004 / CARBURETOR

REF - NO	PART NUMBER	PART NAME	QUANTITY	REMARKS
1	68T-14301-11-00	CARBURETOR ASSY 1	1	UR F8
2	6E5-14321-00-00	.SCREW, THROTTLE	1	
3	6J8-14334-00-00	.SPRING, THROTTLE	1	
4	97980-04112-00	.SCREW, WITH WASHER	5	
5	68T-14385-00-00	.FLOAT	1	
6	67D-14966-00-00	.RUBBER CAP	1	
7	67D-14386-00-00	.PIN, FLOAT	1	
8	68T-14546-00-00	.VALVE, NEEDLE	1	
9	68T-1492E-37-00	.JET, MAIN (#74)	1	
10	68T-1492F-1K-00	.JET, AIR SLOW (#39)	1	
11	68T-1492A-00-00	.NOZZLE, MAIN	1	
12	67D-14984-00-00	.GASKET, FLOAT CHAMBER	1	
13	68T-14981-00-00	.BODY, FLOAT CHAMBER	1	
14	6J8-14959-00-00	..GASKET	1	
15	66T-14991-00-00	..PLUG, DRAIN	1	
16	67D-14323-00-00	.SCREW, AIR ADJUSTING	1	
17	67D-14536-00-00	.GASKET	1	
18	67D-14527-00-00	.PLATE	1	
19	68T-14126-00-00	.PLUG	1	
20	67D-1432A-00-00	.PLUG	1	

F8MSHC 2004 / OIL PUMP

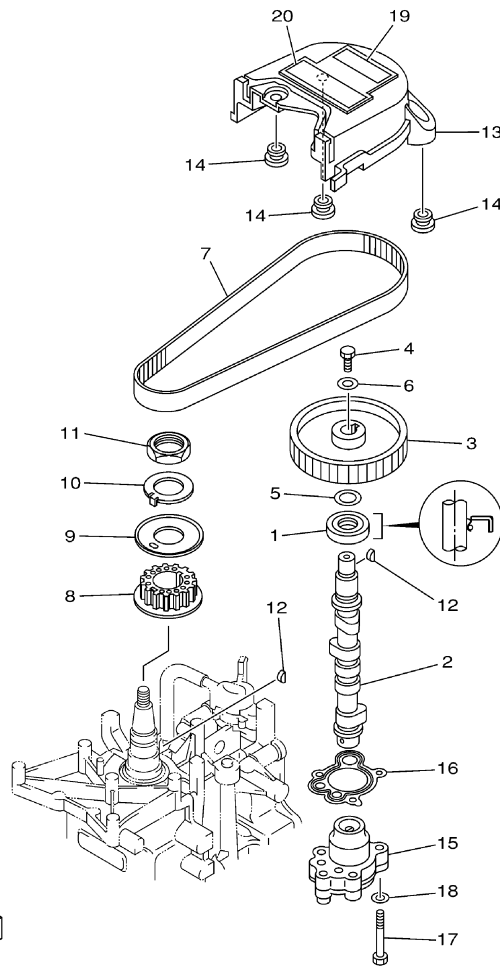

FWD
68R1100-2080

Part List

F8MSHC 2004 / OIL PUMP

REF - NO	PART NUMBER	PART NAME	QUANTITY	REMARKS
1	93102-18M21-00	.OIL SEAL	1	
2	68T-12171-00-00	CAMSHAFT 1	1	
3	66M-11537-00-94	GEAR, DRIVEN	1	
4	97013-06016-00	BOLT	1	
5	90201-13201-00	WASHER, PLATE	1	
6	90201-06M94-00	WASHER, PLATE	1	
7	68T-46241-00-00	BELT	1	
8	68T-11536-00-00	GEAR, DRIVE	1	
9	68T-11557-00-00	WASHER 1	1	
10	6G8-11587-01-00	WASHER, LOCK	1	
11	90170-24M09-00	NUT	1	
12	90280-03M01-00	.KEY, WOODRUFF	2	
13	68T-46297-00-00	COVER, DUST	1	
14	90480-10627-00	GROMMET	3	
15	68T-13300-00-00	OIL PUMP ASSY	1	
16	68T-13329-00-00	.GASKET, PUMP COVER	1	
17	97095-06030-00	BOLT	3	
18	92995-06600-00	WASHER	3	
19	6G9-12138-40-00	MARK, CAUTION	1	
20	68T-13437-41-00	MARK, CAUTION	1	

F8MSHC 2004 / FUEL 1

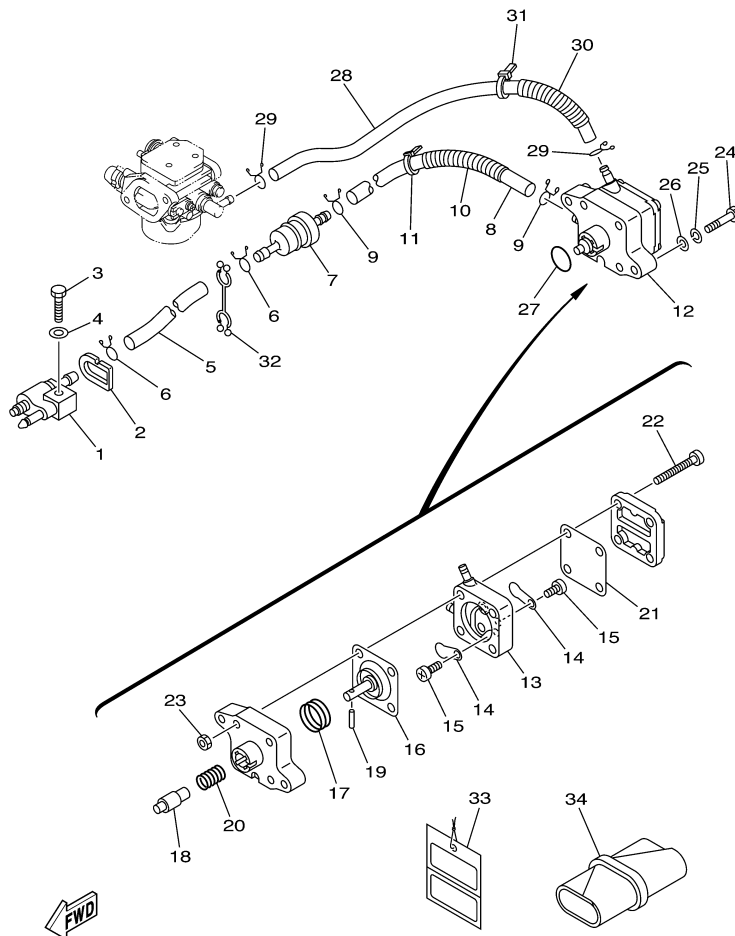

68R3100-C090

©2014 Yamaha Motor Corporation, U.S.A. All rights reserved.

Part List

F8MSHC 2004 / FUEL 1

REF - NO	PART NUMBER	PART NAME	QUANTITY	REMARKS
1	6G1-24304-02-00	FUEL PIPE JOINT COMP. 1	1	
2	61N-24329-00-00	SEAL	1	
3	97095-06025-00	BOLT	1	
4	92995-06600-00	WASHER	1	
5	90445-10M18-00	.HOSE (L295)	1	
6	90467-09M09-00	CLIP	2	
7	68T-24251-00-00	STRAINER 1	1	
8	90445-10M50-00	HOSE (L170)	1	
9	90467-09M09-00	CLIP	2	
10	90446-14M66-00	HOSE (L40)	1	
11	90465-11M10-00	CLAMP	1	
12	68T-24410-00-00	FUEL PUMP ASSY	1	
13	66M-24413-01-00	.BODY 2	1	
14	6A0-24421-01-00	.VALVE, CHECK	2	
15	6E7-14325-00-00	.SCREW, PAN HEAD	2	
16	66M-24411-00-00	.DIAPHRAGM	1	
17	66M-24423-00-00	.SPRING, DIAPHRAGM	1	
18	66M-13131-00-00	.PLUNGER	1	
19	66M-24374-00-00	.PIN	1	
20	66M-24454-00-00	.SPRING	1	
21	66M-24471-00-00	.DIAPHRAGM	1	
22	66M-24444-00-00	.SCREW	4	
23	95380-05600-00	.NUT	4	
24	97095-06030-00	BOLT	2	
25	92995-06100-00	WASHER, SPRING	2	
26	92995-06600-00	WASHER	2	
27	93210-20M65-00	.O-RING	1	
28	90445-10016-00	HOSE (L280)	1	
29	90467-09M09-00	CLIP	2	
30	90446-14M66-00	HOSE (L40)	1	
31	90465-11M10-00	CLAMP	1	
32	90464-10M53-00	CLAMP	1	
33	61H-2819R-31-00	TAG, WARNING	1	

F8MSHC 2004 / FUEL 2

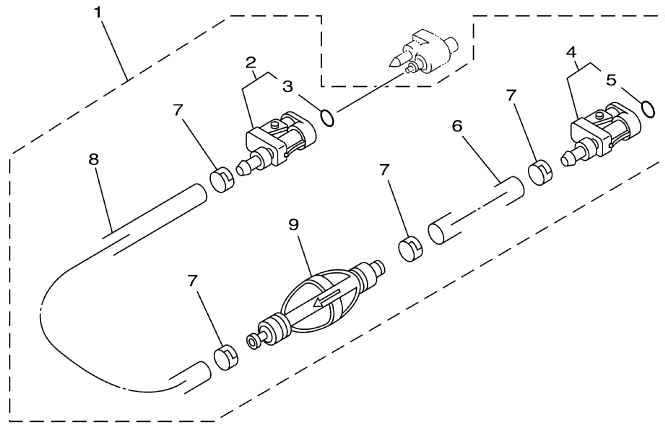

68R3100-C100

©2014 Yamaha Motor Corporation, U.S.A. All rights reserved.

Part List

F8MSHC 2004 / FUEL 2

REF - NO	PART NUMBER	PART NAME	QUANTITY	REMARKS
1	6Y2-24306-55-00	FUEL PIPE COMP. 1	1	AP
2	6E5-24305-05-00	.FUEL PIPE JOINT COMP 2	1	
3	93210-08287-00	..O-RING	1	
4	6Y2-24305-05-00	.FUEL PIPE JOINT COMP 2	1	
5	93210-08287-00	..O-RING	1	
6	90445-13M01-00	.HOSE (L2050)	1	
7	6E5-24351-51-00	.BAND 1	4	
8	90445-13M00-00	.HOSE (L850)	1	
9	6Y2-24360-60-00	.PRIMER PUMP ASSY	1	

F8MSHC 2004 / STARTER

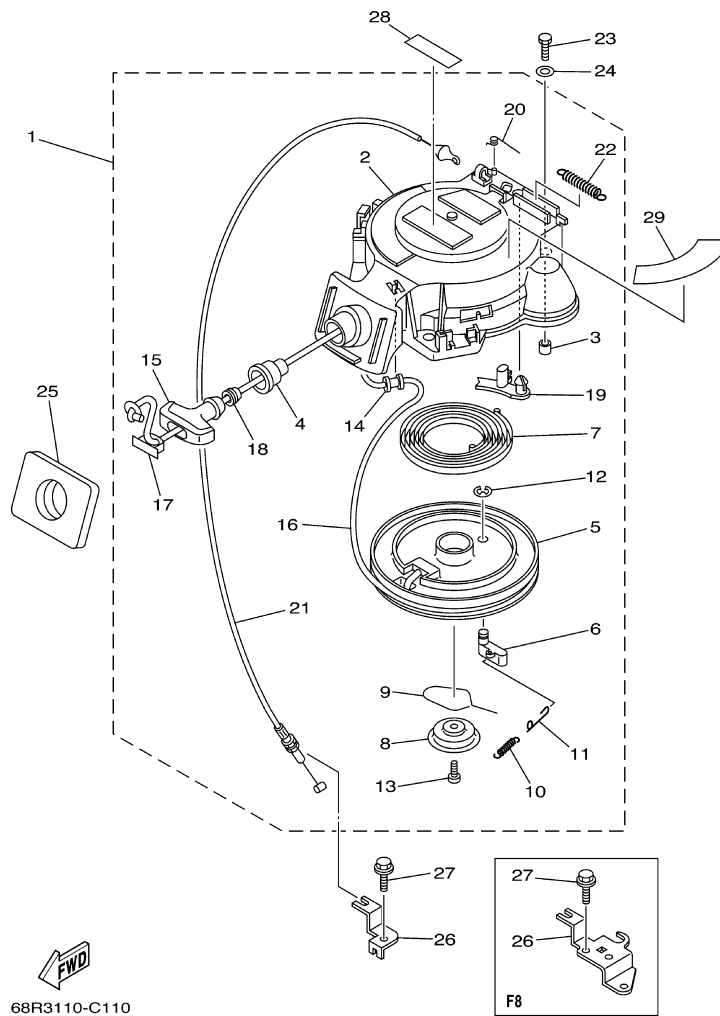

68R3110-C110

*1: CUT FROM 50M ROLLS, PART NO.90890-44373, CUTTING LENGTH 1.8M

Part List

F8MSHC 2004 / STARTER

REF - NO	PART NUMBER	PART NAME	QUANTITY	REMARKS
1	68T-15710-01-00	STARTER ASSY	1	
2	68T-15711-01-00	.CASE, STARTER	1	
3	67D-15764-00-00	.COLLAR 1	3	
4	68T-15795-00-00	.GUIDE, ROPE	1	
5	63V-15714-00-00	.DRUM, SHEAVE	1	
6	63V-15741-00-00	.PAWL, DRIVE	1	
7	63V-15713-00-00	.SPRING, STARTER	1	
8	68T-15716-00-00	.PLATE, DRIVE	1	
9	63V-15705-01-00	.SPRING, DRIVE PAWL	1	
10	63V-15767-01-00	.SPRING	1	
11	68T-15784-00-00	.SPRING, RETURN	1	
12	63V-15744-00-00	.CIRCLIP	1	
13	68T-15793-00-00	.SCREW	1	
14	68T-15764-00-00	.COLLAR 1	1	
15	6G1-15755-00-00	.HANDLE, STARTER	1	
16	90890-44373-00	..ROPE, STARTER	1	UNAVAILABLE - OBTAIN LOCALLY CUT TO 1.8M
17	6G1-15779-00-00	.COVER	1	
18	6A0-15789-00-00	.DAMPER	1	
19	66T-15794-00-00	.STOPPER	1	
20	66T-15734-00-00	.SPRING, RETURN	1	
21	68T-15770-00-00	.CABLE COMP, STARTER STOP	1	
22	66T-15731-00-00	.SPRING, RETURN	1	
23	97095-06020-00	BOLT	3	
24	92995-06600-00	WASHER	3	
25	68T-15762-00-00	SEAL, RUBBER 2	1	
26	68T-15774-10-00	STAY 4	1	UR F8
27	90109-06M86-00	BOLT	2	UR F8
28	6A1-83625-41-00	MARK 5	1	
29	68T-85711-40-00	MARK, CAUTION	1	

F8MSHC 2004 / GENERATOR

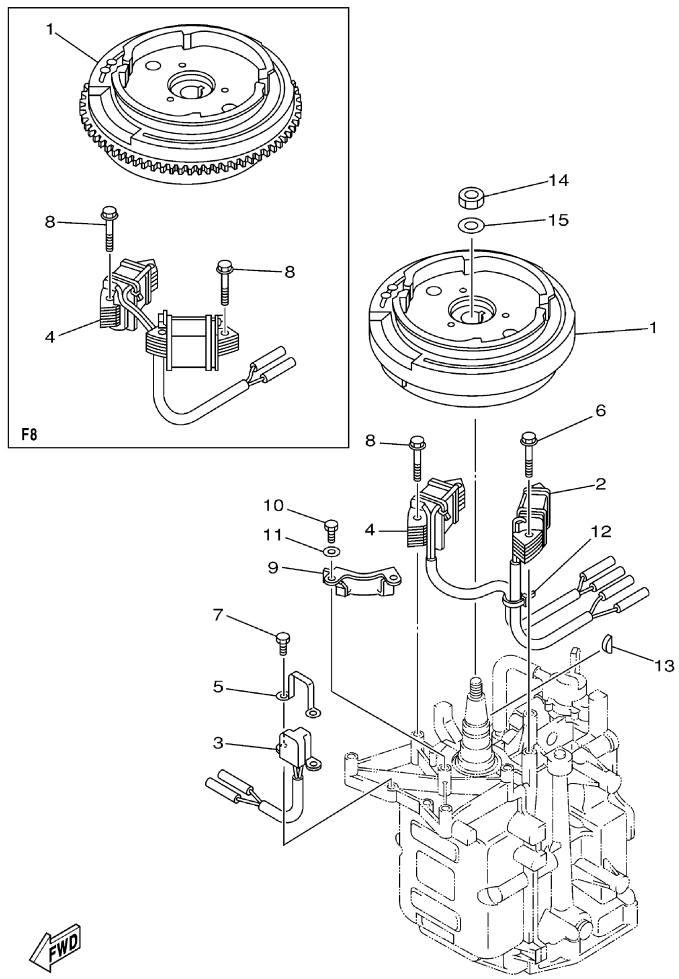

68R0110-1120

Part List

F8MSHC 2004 / GENERATOR

REF - NO	PART NUMBER	PART NAME	QUANTITY	REMARKS
1	68T-85550-11-00	ROTOR ASSY	1	UR F8
2	68T-85520-00-00	COIL, CHARGE	1	
3	68T-85580-01-00	COIL, PULSER	1	
4	68T-85533-10-00	COIL, LIGHTING	1	UR F8
5	6H2-85582-00-00	ATTACHMENT, PULSER	1	
6	90119-06014-00	BOLT, WITH WASHER	2	
7	97095-05010-00	BOLT	2	
8	90119-06MA1-00	BOLT, WITH WASHER	4	UR F8
12	90465-11M10-00	CLAMP	1	
13	90280-04M06-00	KEY, WOODRUFF	1	
14	90170-12066-00	NUT	1	
15	90201-12472-00	WASHER, PLATE	1	

F8MSHC 2004 / ELECTRICAL 1

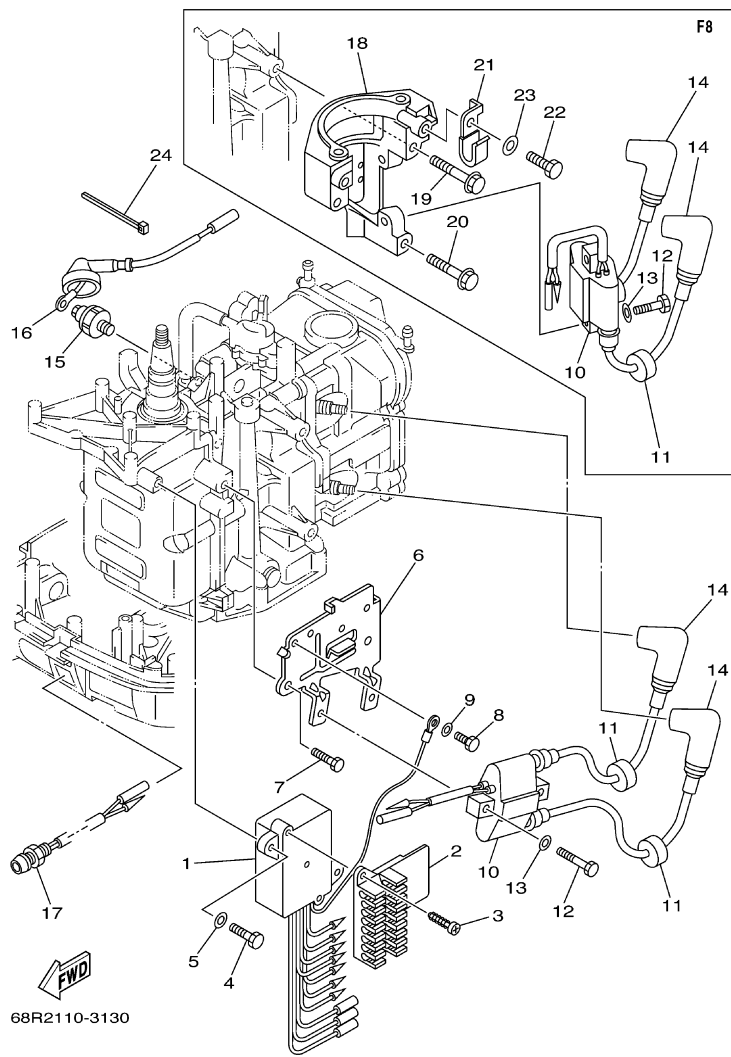

©2014 Yamaha Motor Corporation, U.S.A. All rights reserved.

Part List

F8MSHC 2004 / ELECTRICAL 1

REF - NO	PART NUMBER	PART NAME	QUANTITY	REMARKS
1	68T-85540-00-00	C.D.I. UNIT ASSY	1	UR F8
2	68T-82522-00-00	CLAMP, COUPLER	1	
3	97780-40512-00	SCREW, TAPPING	2	
4	97095-06020-00	BOLT	2	
5	92995-06600-00	WASHER	2	
8	97095-06012-00	BOLT	1	
9	92995-06600-00	WASHER	1	
10	680-85570-00-00	IGNITION COIL ASSY	1	
11	90480-25161-00	GROMMET	2	
12	97095-06025-00	BOLT	2	
13	92995-06600-00	WASHER	2	
14	6E3-82370-21-00	PLUG CAP ASSY	2	
15	67F-82504-00-00	OIL PRESSURE SWITCH ASSY	1	
16	68T-82127-10-00	WIRE, LEAD 2	1	
17	68T-85410-00-00	EMERGENCY SIGNAL LIGHT ASSY	1	
18	68T-81822-00-94	BRACKET, STARTING MOTOR	1	F8
19	90119-08046-00	BOLT, WITH WASHER	2	F8
20	90119-08020-00	BOLT, WITH WASHER	1	F8
21	90465-08M99-00	CLAMP	1	F8
22	97095-06012-00	BOLT	1	F8
23	92995-06600-00	WASHER	1	F8
24	90465-11M10-00	CLAMP	1	F8

F8MSHC 2004 / ELECTRICAL 2

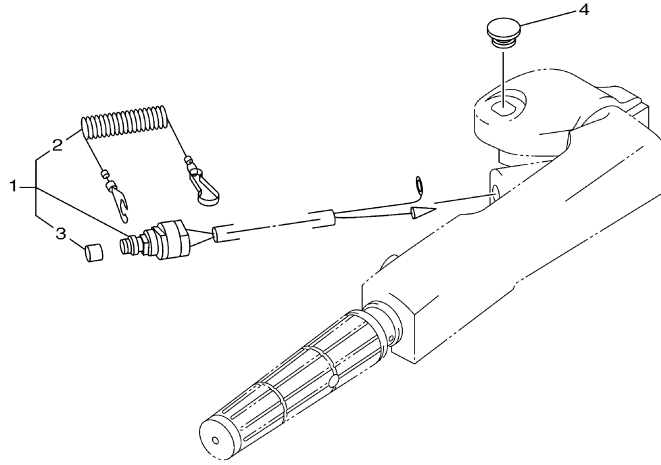

68R0100-0130

Part List

F8MSHC 2004 / ELECTRICAL 2

REF - NO	PART NUMBER	PART NAME	QUANTITY	REMARKS
1	65W-82575-01-00	ENGINE STOP SWITCH ASSY	1	
2	682-82556-00-00	.LANYARD, STOP SWITCH	1	
3	689-8257Y-00-00	.CAP	1	
4	6G1-42725-00-00	GROMMET	1	

Part Notes

F8MSHC 2004 / ELECTRICAL 2

PART NUMBER	NOTE TEXT
682-82556-00-00 	OEM: This part number is among the Top 100 Most Popular Marine Maintenance Parts as of March 2014.

©2014 Yamaha Motor Corporation, U.S.A. All rights reserved.

F8MSHC 2004 / BOTTOM COWLING

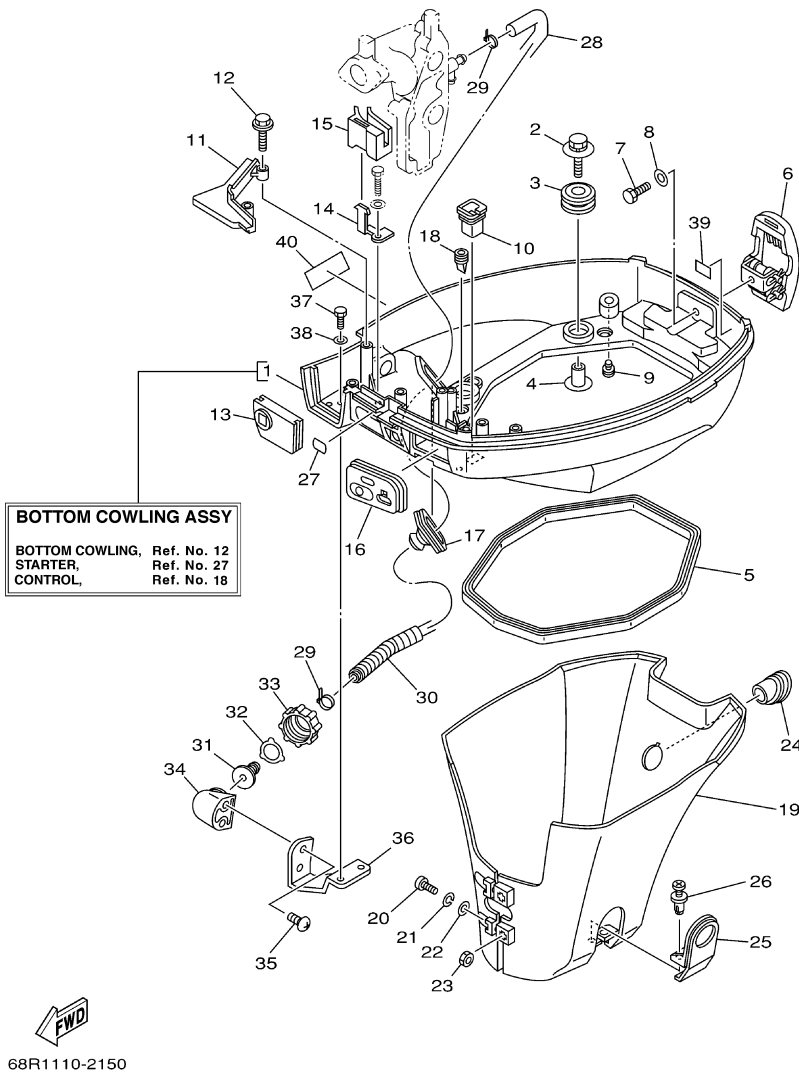

Part List

F8MSHC 2004 / BOTTOM COWLING

REF - NO	PART NUMBER	PART NAME	QUANTITY	REMARKS
1	68T-42710-00-4D	BOTTOM COWLING ASSY	1	WITH TAPPING BOLT
2	68F-85119-00-00	BOLT	4	
3	90480-21M82-00	GROMMET	4	
4	90387-06053-00	COLLAR	4	
5	68T-42716-10-00	RUBBER, SEAL 1	1	
6	68T-42801-00-00	COWLING CLAMP COMP.	1	
7	97095-06012-00	BOLT	1	
8	92995-06600-00	WASHER	1	
9	6H3-44391-01-00	NIPPLE, HOSE	1	
10	682-42727-00-00	GROMMET	1	
11	68T-42738-00-4D	PLATE, FITTING	1	
12	90109-06M81-00	BOLT	2	
13	68T-42725-00-00	GROMMET	1	
14	68T-26393-00-00	HOLDER	1	
15	68T-26367-00-00	PROTECTOR	1	
16	68T-42724-20-00	GROMMET	1	
17	688-42726-10-00	GROMMET	1	FLUSHING KIT
18	65W-42717-00-00	RUBBER, SEAL 2	2	
19	68T-42741-00-00	APRON	1	
20	97885-06030-00	SCREW, PAN HEAD	2	
21	92995-06100-00	WASHER, SPRING	2	
22	92995-06600-00	WASHER	2	
23	95380-06600-00	NUT, HEXAGON	2	
24	68T-42717-00-00	RUBBER, SEAL 2	1	
25	68T-42771-00-00	APRON	1	
26	90338-06M20-00	PLUG	2	
27	65W-84342-00-00	SEAT, EMBLEM	1	
28	6E5-12481-00-00	PIPE 1	1	FLUSHING KIT
29	90465-11M10-00	CLAMP	2	FLUSHING KIT
30	90447-13M00-00	TUBE	1	FLUSHING KIT
31	6R3-12582-00-00	JOINT, HOSE 2	1	FLUSHING KIT
32	6R3-12583-00-00	GASKET, HOSE JOINT	1	FLUSHING KIT
33	6R3-12581-00-00	JOINT, HOSE 1	1	FLUSHING KIT
34	68T-12572-00-00	ADAPTER	1	FLUSHING KIT
35	90167-06002-00	SCREW, TAPPING	2	FLUSHING KIT
36	68T-12535-00-00	PLATE	1	FLUSHING KIT
37	97095-06010-00	BOLT	2	FLUSHING KIT
38	92995-06600-00	WASHER	2	FLUSHING KIT
39	6H8-42791-10-00	MARK 1	1	
40	62Y-13444-40-00	MARK	1	

F8MSHC 2004 / STEERING

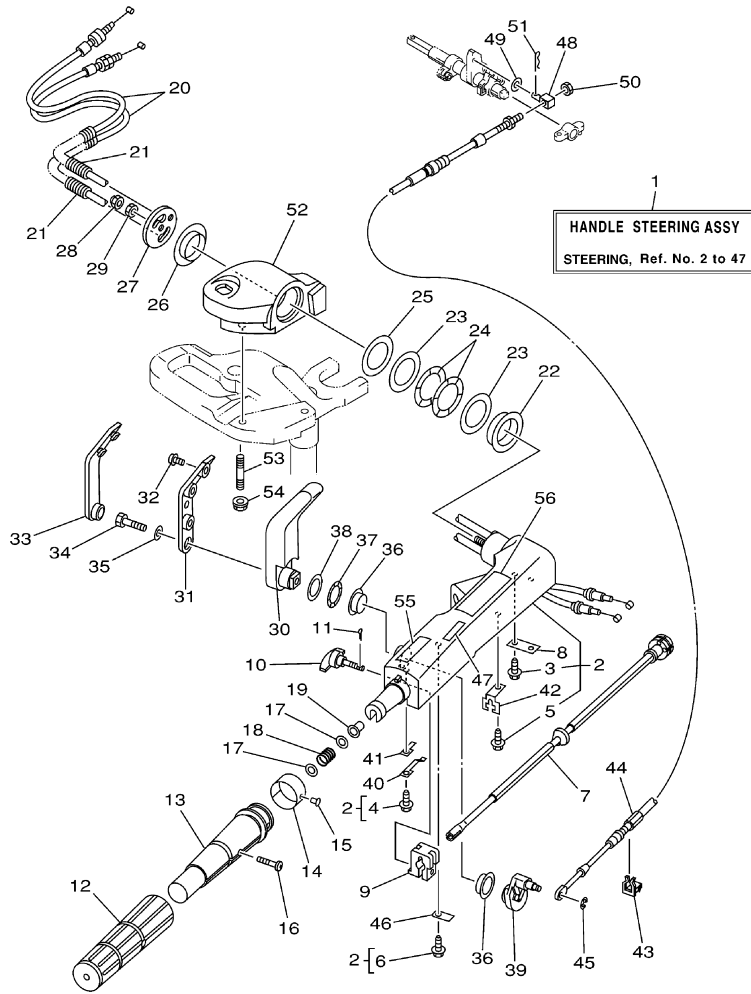

68R1110-2160

©2014 Yamaha Motor Corporation, U.S.A. All rights reserved.

Part List

F8MSHC 2004 / STEERING

REF - NO	PART NUMBER	PART NAME	QUANTITY	REMARKS
1	68T-W0084-10-4D	HANDLE STEERING ASSY	1	
2	66R-42101-01-4D	HANDLE, STEERING	1	
3	90109-06M86-00	.BOLT	2	
4	90109-06M80-00	.BOLT	1	
5	90109-06M80-00	.BOLT	1	
6	90109-06M80-00	.BOLT	1	
7	68T-42138-01-00	LEVER, THROTTLE	1	
8	65W-42159-00-00	STAY	1	
9	6G1-42126-00-00	FRICTION, STEERING HANDLE GRIP	1	
10	65W-42125-00-00	BOLT, FRICTION ADJUSTING	1	
11	91490-16010-00	PIN. COTTER	1	
12	67D-42177-00-00	RUBBER, HANDLE	1	
13	67D-42119-00-00	GRIP, STEERING HANDLE	1	
14	68T-42137-00-00	INDICATOR, THROTTLE	1	UR F8
15	90269-02M09-00	RIVET	1	
16	90149-05M13-00	SCREW	1	
17	90201-10M02-00	WASHER, PLATE	2	
18	90501-23215-00	SPRING, COMPRESSION	1	
19	90386-08032-00	BUSH	1	
20	68T-26301-11-00	THROTTLE CABLE ASSY	2	
21	90447-07005-00	TUBE	2	
22	66R-42171-00-00	BUSHING	1	
23	90201-43M00-00	WASHER, PLATE	2	
24	90206-43M22-00	WASHER, WAVE	2	
25	90202-43M57-00	WASHER, PLATE	1	
26	90386-40M99-00	BUSH	1	
27	66M-42131-01-00	COVER, HANDLE STEERING	1	
28	95780-10300-00	NUT, FLANGE	1	
29	95380-10700-00	NUT	1	
30	66R-44111-00-4D	HANDLE, GEAR SHIFT	1	
31	66R-44173-00-00	LEVER, SHIFT CONTROL	1	
32	90159-06M18-00	SCREW, WITH WASHER	3	
33	66R-42129-00-00	BUSHING, RUBBER	1	
34	97095-08030-00	BOLT	1	
35	92995-08600-00	WASHER	1	
36	90386-26MA3-00	BUSH	2	
37	90206-26M25-00	WASHER, WAVE	1	
38	90202-26M59-00	WASHER, PLATE	1	
39	68T-44113-01-00	CAM PLATE, HANDLE	1	
40	66R-44116-00-00	SPRING	1	
41	66R-44118-00-00	BRACKET	1	
42	66R-48538-00-00	CLAMP, CABLE 1	1	
43	63D-48538-00-00	CLAMP, CABLE 1	1	
44	68T-48321-00-00	CABLE	1	
45	99080-04600-00	CIRCLIP	1	
46	66R-44114-00-00	STOPPER	1	
47	6E0-44191-11-00	INDICATOR, SHIFT	1	
48	66R-48344-00-00	CABLE END, REMOTE CONTROL	1	
49	90201-06M62-00	WASHER, PLATE	1	
50	90170-05M38-00	NUT	1	
51	91490-20012-00	PIN. COTTER	1	
52	68T-42121-10-4D	BRACKET	1	
53	90116-10019-00	BOLT, STUD	2	
54	90179-10M33-00	NUT	2	
55	6E0-83627-41-00	LABEL, CAUTION 7	1	
56	6G9-1571Y-40-00	MARK, CAUTION	1	

F8MSHC 2004 / STEERING FRICTION

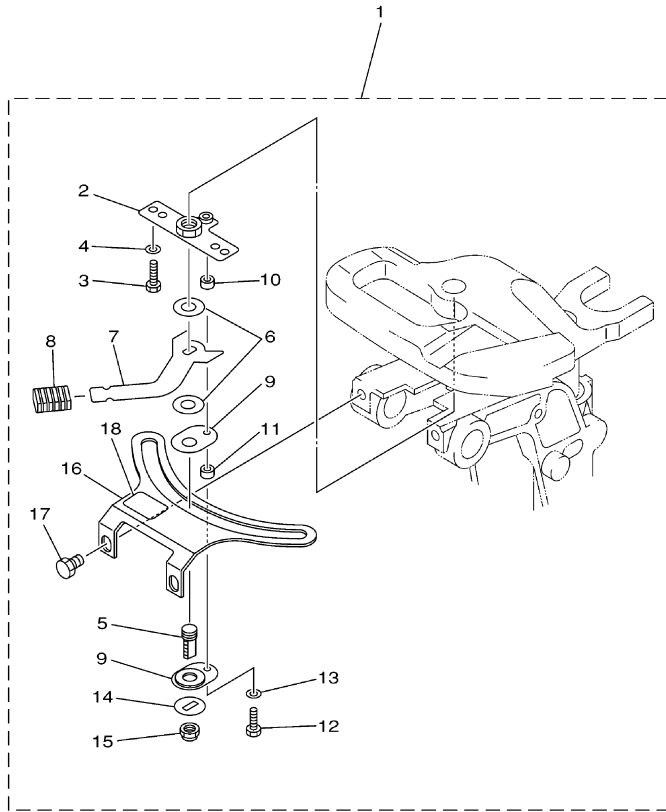

68R1100-2170

Part List

F8MSHC 2004 / STEERING FRICTION

REF - NO	PART NUMBER	PART NAME	QUANTITY	REMARKS
1	68T-42508-00-00	STEERING FRICTION ASSY	1	
2	68T-42525-01-00	.PLATE, FRICTION	1	
3	97095-05020-00	.BOLT	2	
4	92995-05600-00	.WASHER	2	
5	67C-42562-00-00	.SHAFT, STEERING LOCK	1	
6	90202-10M56-00	.WASHER, PLATE	2	
7	68T-42561-00-00	.KNOB, STEERING LOCK	1	
8	689-43633-00-00	.COVER, TILT LEVER	1	
9	65W-42528-00-00	.PLATE, FRICTION	2	
10	90387-05M05-00	.COLLAR	1	
11	90387-05M11-00	.COLLAR	1	
12	97095-05020-00	.BOLT	1	
13	92995-05600-00	.WASHER	1	
14	90209-10M26-00	.WASHER	1	
15	90185-10M14-00	.NUT, SELF-LOCKING	1	
16	68T-42527-00-00	.PLATE, FRICTION	1	
17	90109-08M91-00	.BOLT	2	
18	68T-43155-00-00	.MARK 1	1	

F8MSHC 2004 / CONTROL

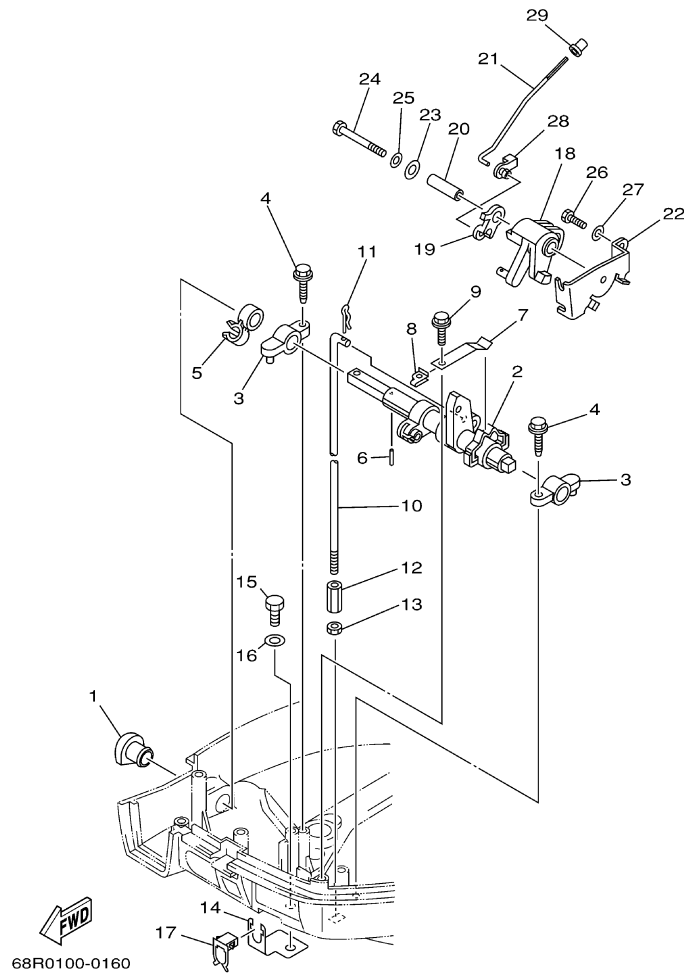

©2014 Yamaha Motor Corporation, U.S.A. All rights reserved.

Part List

F8MSHC 2004 / CONTROL

REF - NO	PART NUMBER	PART NAME	QUANTITY	REMARKS
1	68T-42726-00-00	GROMMET	1	
2	68T-44121-01-00	LEVER, SHIFT ROD	1	
3	6G1-41662-01-94	BRACKET 2	2	
4	90109-06M81-00	BOLT	2	
5	90464-10M60-00	CLAMP	1	
6	91690-30014-00	PIN, SPRING	1	
7	65W-44116-00-00	SPRING	1	
8	66R-44117-00-00	BRACKET	1	
9	90109-06M86-00	BOLT	1	
10	68T-44143-10-00	ROD, SHIFT	1	UR L
10	68T-44143-00-00	ROD, SHIFT	1	UR S
11	90468-18001-00	CLIP	1	
12	90170-06015-00	NUT	1	
13	95380-06700-00	NUT	1	
14	68T-48538-00-00	CLAMP, CABLE 1	1	
15	97095-06012-00	BOLT	1	
16	92995-06600-00	WASHER	1	
17	63D-48538-00-00	CLAMP, CABLE 1	1	
18	68T-41638-00-00	PULLEY	1	
19	68T-41283-00-00	LEVER, FREE ACCEL.	1	UR F8
20	90387-06M59-00	COLLAR	1	
21	68T-41211-00-00	LINK, ACCEL.	1	
22	68T-14497-00-00	STAY, THROTTLE WIRE	1	
23	90201-06M62-00	WASHER, PLATE	1	
24	97095-06045-00	.BOLT	1	
25	92995-06600-00	WASHER	1	
26	97095-06012-00	BOLT	1	
27	92995-06600-00	WASHER	1	
28	661-41262-02-00	JOINT, CHOKE LEVER	1	
29	647-14395-60-00	CAP, OVERFLOW PIPE	1	

F8MSHC 2004 / REMOTE CONTROL ATTACHMENT

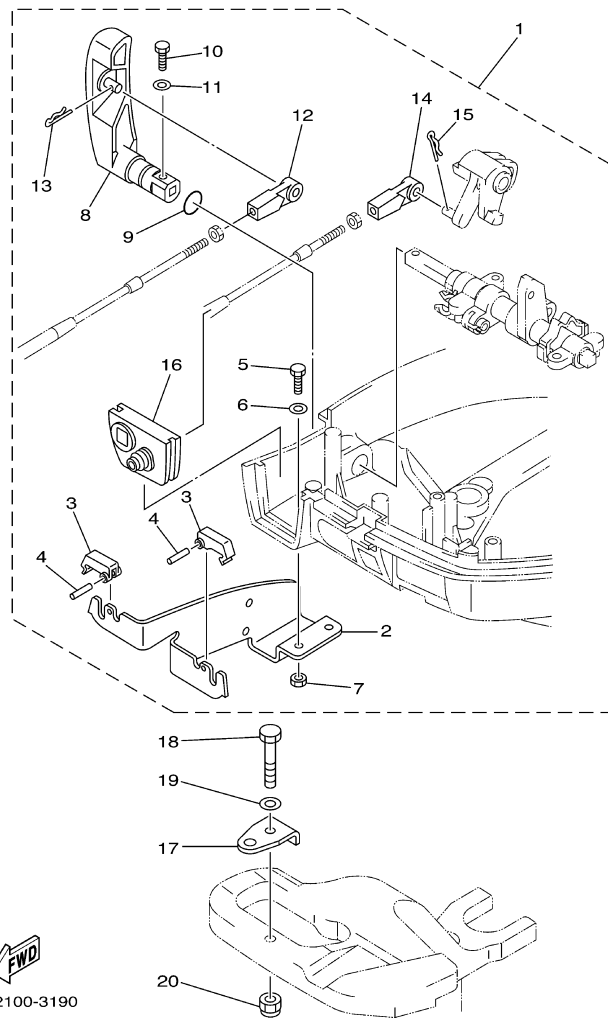

68R2100-3190



Part List

F8MSHC 2004 / REMOTE CONTROL ATTACHMENT

REF - NO	PART NUMBER	PART NAME	QUANTITY	REMARKS
1	68R-48501-00-00	REMOTE CONT. ATTACHMENT ASSY.	1	AP
2	68T-48531-00-00	.BRACKET, REMOTE CONTROL 1	1	
3	682-48538-50-00	.CLAMP, CABLE 1	2	
4	91690-30012-00	.PIN, SPRING	2	
5	97095-06012-00	.BOLT	2	
6	92995-06600-00	.WASHER	2	
7	95380-06600-00	.NUT, HEXAGON	2	
8	68T-44111-10-00	.HANDLE, GEAR SHIFT	1	
9	93210-12327-00	.O-RING	1	
10	97095-05016-00	.BOLT	1	
11	92995-05600-00	.WASHER	1	
12	663-48344-00-00	.CABLE END, REMOTE CONTROL	1	
13	90468-18008-00	.CLIP	1	
14	663-48344-00-00	.CABLE END, REMOTE CONTROL	1	
15	90468-18008-00	.CLIP	1	
16	68T-42725-10-00	.GROMMET	1	
17	63V-48511-01-00	HOOK, STEERING	1	AP F8
18	97075-08035-00	BOLT	1	AP F8
19	92995-08600-00	WASHER	1	AP F8
20	90185-08057-00	NUT, SELF-LOCKING	1	AP F8

Part Notes

F8MSHC 2004 / REMOTE CONTROL ATTACHMENT

PART NUMBER	NOTE TEXT
90468-18008-00 	OEM: This part number is among the Top 100 Most Popular Marine Maintenance Parts as of March 2014.
90468-18008-00 	OEM: This part number is among the Top 100 Most Popular Marine Maintenance Parts as of March 2014.

©2014 Yamaha Motor Corporation, U.S.A. All rights reserved.

F8MSHC 2004 / BRACKET 1

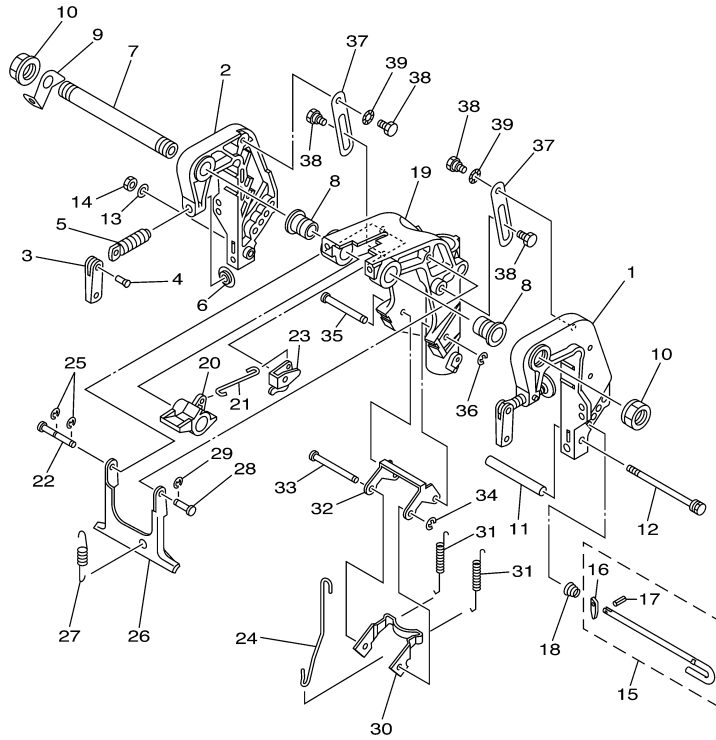

68R3110-C200

Part List

F8MSHC 2004 / BRACKET 1

REF - NO	PART NUMBER	PART NAME	QUANTITY	REMARKS
1	68T-43111-02-4D	BRACKET, CLAMP	1	
2	68T-43112-02-4D	BRACKET, CLAMP	1	
3	6E0-43118-01-00	HANDLE, TRANSOM CLAMP	2	
4	90243-04M01-00	PIN	2	
5	677-43116-01-00	SCREW, TRANSOM CLAMP	2	
6	648-43114-01-00	PAD, TRANSOM CLAMP	2	
7	68T-43131-00-00	BOLT, CLAMP BRACKET (L:215.5MM)	1	
8	90386-22MA4-00	BUSH	2	
9	66R-43113-00-00	PLATE, CLAMP BRACKET	1	
10	90185-22043-00	NUT, SELF-LOCKING	2	
11	90387-06M13-00	COLLAR	1	
12	90101-06M18-00	BOLT	1	
13	92990-06600-00	WASHER, PLATE	1	
14	95380-06700-00	NUT	1	
15	6L2-43160-01-00	TILT ROD ASSY	1	
16	689-43165-00-00	.PLATE, TILT LOCK	1	
17	91690-30008-00	.PIN, SPRING	1	
18	90502-10M07-00	SPRING, CONICAL	1	
19	68T-43311-10-4D	BRACKET, SWIVEL 1	1	UR L
19	68T-43311-00-4D	BRACKET, SWIVEL 1	1	UR S
20	68T-43631-00-00	LEVER, TILT	1	
21	68T-43616-00-00	ROD, TILT LOCK	1	
22	68T-43646-00-00	SHAFT, LEVER	1	
23	68T-43641-00-00	LEVER, TILT	1	
24	68T-43617-00-00	ROD, TILT LOCK	1	
25	99080-05600-00	CIRCLIP	2	
26	68T-43350-00-00	RECEIVER ASSY	1	
27	90506-20005-00	SPRING, TENSION	1	UR L
27	90506-18M41-00	SPRING, TENSION	1	UR S
28	63V-43191-00-00	SHAFT, STOPPER	1	
29	99080-05600-00	CIRCLIP	1	
30	68T-43614-00-00	PLATE, TILT LOCK	1	
31	90506-23003-00	SPRING, TENSION	2	UR L
31	90506-20M42-00	SPRING, TENSION	2	UR S
32	68T-43615-00-00	PLATE, TILT LOCK	1	
33	68T-43611-00-00	SHAFT, TILT LOCK	1	
34	93430-04M03-00	CIRCLIP	1	
35	68T-43659-00-00	SHAFT, REVERSE LOCK	1	
36	99080-05600-00	CIRCLIP	1	
37	68T-43627-00-00	STOPPER	2	
38	90109-06M84-00	BOLT	4	
39	90206-10M24-00	WASHER, WAVE	2	

Part Notes

F8MSHC 2004 / BRACKET 1

PART NUMBER	NOTE TEXT
92990-06600-00 	OEM: This part number is among the Top 100 Most Popular Marine Maintenance Parts as of March 2014.

©2014 Yamaha Motor Corporation, U.S.A. All rights reserved.

F8MSHC 2004 / BRACKET 2

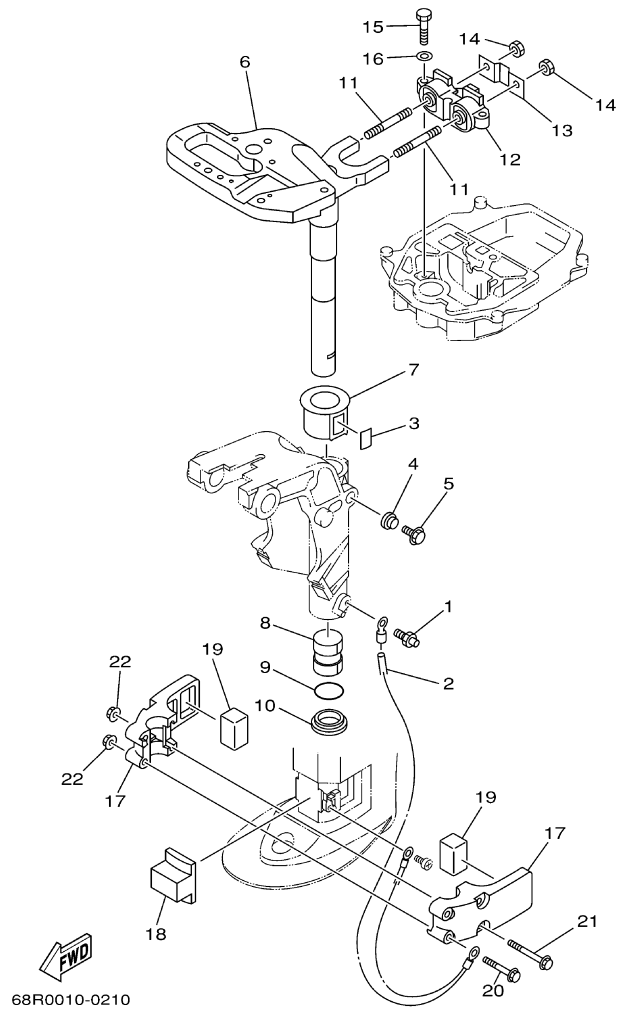

©2014 Yamaha Motor Corporation, U.S.A. All rights reserved.

Part List

F8MSHC 2004 / BRACKET 2

REF - NO	PART NUMBER	PART NAME	QUANTITY	REMARKS
1	93700-06M03-00	NIPPLE, GREASE	1	
2	68T-82127-00-00	WIRE, LEAD 2	1	
3	63V-42528-00-00	PLATE, FRICTION	1	
4	689-43373-01-00	SEAL, DAMPER	1	
5	90105-06M07-00	.BOLT, FLANGE	1	
6	68T-42511-11-4D	BRACKET, STEERING	1	UR L
6	68T-42511-01-4D	BRACKET, STEERING	1	UR S
7	63V-42537-00-00	BUSHING, PIVOT SHAFT	1	
8	90386-30048-00	BUSH	1	
9	93210-29M94-00	O-RING	1	
10	90386-30M60-00	BUSH	1	
11	90116-08M54-00	BOLT, STUD	2	
12	68T-44517-00-94	MOUNT RUBBER	1	
13	68T-44526-00-00	PLATE	1	
14	95380-08600-00	NUT	2	
15	97075-06025-00	BOLT	2	
16	92995-06600-00	WASHER	2	
17	68T-44551-00-4D	HOUSING, LOWER MOUNT RUBBER 1	2	
18	68T-44557-00-00	MOUNT DAMPER, LOWER FRONT	1	
19	682-44555-00-00	MOUNT DAMPER, LOWER SIDE	2	
20	90119-06012-00	BOLT, WITH WASHER	2	
21	90119-06013-00	BOLT, WITH WASHER	2	
22	90179-06M28-00	NUT	4	

F8MSHC 2004 / UPPER CASING

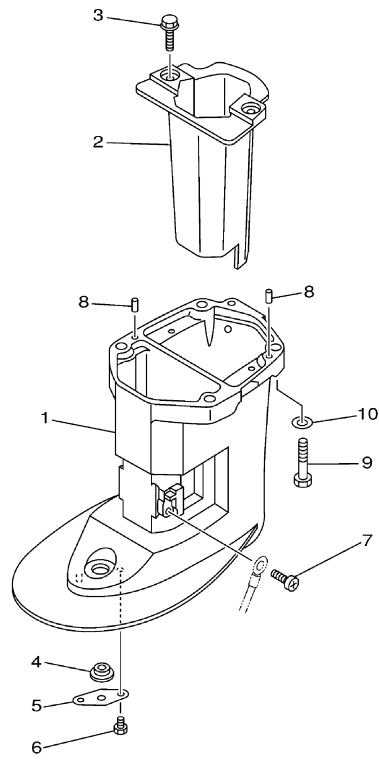

68R0010-0220

Part List

F8MSHC 2004 / UPPER CASING

REF - NO	PART NUMBER	PART NAME	QUANTITY	REMARKS
1	68T-45111-10-4D	CASING, UPPER	1	UR L
1	68T-45111-00-4D	CASING, UPPER	1	UR S
2	68T-14711-00-5B	MUFFLER 1	1	
3	97575-06514-00	BOLT, WITH WASHER	2	
4	90480-14M54-00	GROMMET	1	
5	68T-45321-00-00	PLATE	1	
6	97095-06008-00	BOLT	1	
7	97885-05008-00	SCREW, PAN HEAD	1	
8	93604-12M07-00	PIN, DOWEL	2	
9	97075-08035-00	BOLT	4	
10	92995-08600-00	WASHER	4	

F8MSHC 2004 / OIL PAN

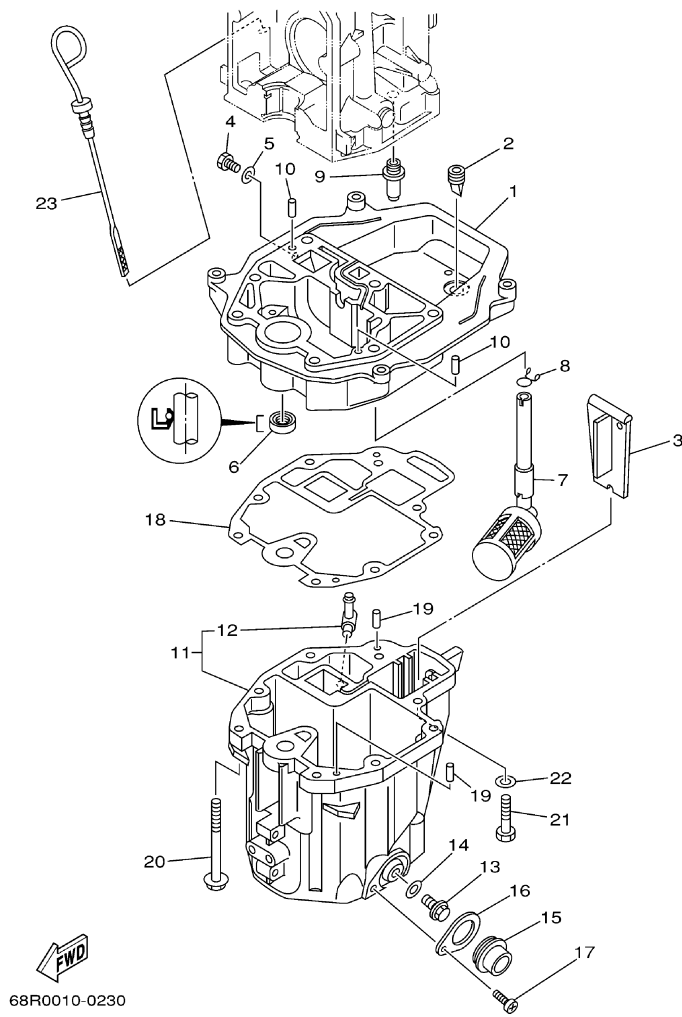

68R0010-0230

Part List

F8MSHC 2004 / OIL PAN

REF - NO	PART NUMBER	PART NAME	QUANTITY	REMARKS
1	68T-41137-00-94	GUIDE, EXHAUST	1	
2	65W-42717-00-00	RUBBER, SEAL 2	1	
3	68T-45181-00-00	PLATE	1	
4	97095-08014-00	BOLT	1	
5	90430-08143-00	GASKET	1	
6	93101-12M70-00	.OIL SEAL	1	
7	68T-13421-01-00	STRAINER 2	1	
8	90467-11M08-00	CLIP	1	
9	6G8-11575-00-00	RELIEF VALVE ASSY	1	
10	93606-19M23-00	PIN, DOWEL	2	
11	68T-15311-00-5B	OIL PAN	1	
12	6H1-11372-00-00	.NIPPLE, HOSE	1	
13	90340-10M10-00	PLUG, STRAIGHT SCREW	1	
14	90430-10M11-00	.GASKET	1	
15	68T-15316-00-00	DAMPER 1	1	
16	68T-15317-00-00	SPACER, ENGINE MOUNT	1	
17	97885-05008-00	SCREW, PAN HEAD	1	
18	68T-13475-00-00	.GASKET	1	
19	93604-12M07-00	PIN, DOWEL	2	
20	90119-08005-00	BOLT, WITH WASHER	6	
21	97075-08030-00	BOLT	2	
22	92995-08600-00	WASHER	2	
23	68T-15362-00-00	PLUG, OIL LEVEL	1	

F8MSHC 2004 / LOWER CASING DRIVE 1

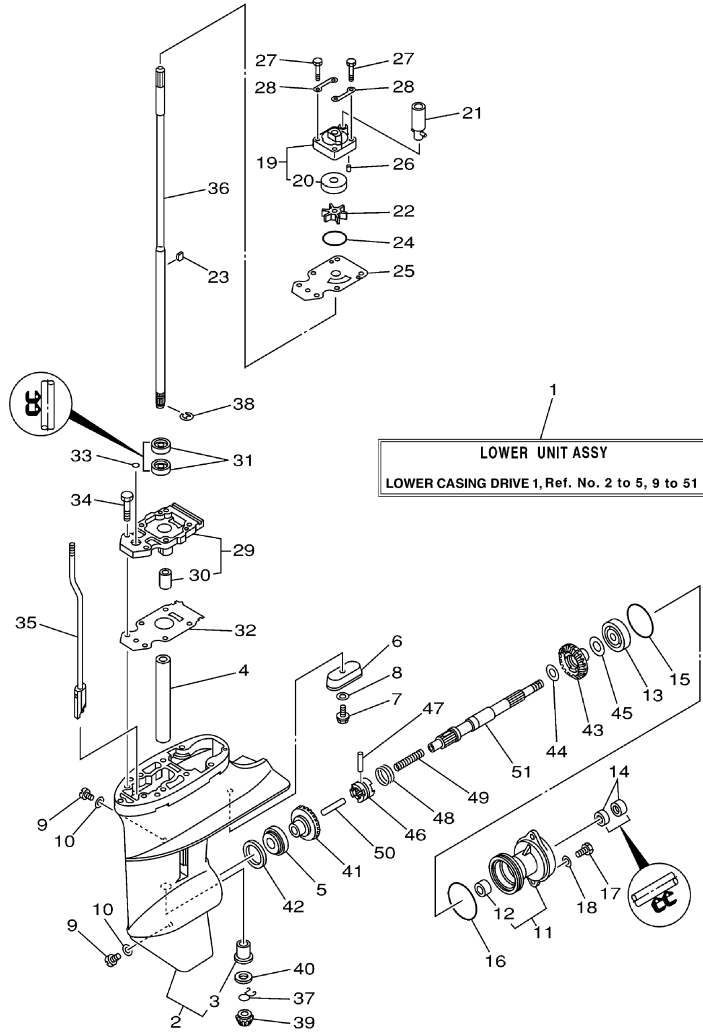

68R0100-1240

©2014 Yamaha Motor Corporation, U.S.A. All rights reserved.

Part List

F8MSHC 2004 / LOWER CASING DRIVE 1

REF - NO	PART NUMBER	PART NAME	QUANTITY	REMARKS
1	68T-45300-10-4D	LOWER UNIT ASSY	1	UR L
1	68T-45300-00-4D	LOWER UNIT ASSY	1	UR S
2	68T-45311-00-4D	CASING, LOWER	1	
3	6G1-45317-09-00	.BUSHING, DRIVE SHAFT	1	
4	90387-14M49-00	COLLAR	1	
5	93306-004U0-00	BEARING	1	
6	68T-45251-00-00	ANODE	1	
7	95895-06016-00	BOLT, FLANGE	1	
8	92990-06300-00	WASHER, INTERNAL TOOTH	1	
9	90340-08002-00	PLUG, STRAIGHT SCREW	2	
10	90430-08020-00	.GASKET	2	
11	6G1-45361-01-4D	CAP, LOWER CASING	1	
12	6G1-45362-09-00	.BUSHING	1	
13	93306-004U0-00	BEARING	1	
14	93101-15074-00	.OIL SEAL	2	
15	93210-49046-00	.O-RING	1	
16	93210-53M08-00	.O-RING	1	
17	97095-06016-00	BOLT	2	
18	92995-06600-00	WASHER	2	
19	63V-44301-00-00	WATER PUMP HOUSING COMP.	1	
20	63V-44322-00-00	.INSERT, CARTRIDGE	1	
21	68T-44366-00-00	.DAMPER, WATER SEAL 2	1	
22	68T-44352-00-00	.IMPELLER	1	
23	664-44338-00-00	.KEY, WOODRUFF	1	
24	93210-44398-00	.O-RING	1	
25	68T-44323-00-00	.OUTER PLATE, CARTRIDGE	1	
26	93604-12M07-00	PIN, DOWEL	2	
27	97080-08045-00	BOLT	4	
28	63V-44328-00-00	PLATE	2	
29	68T-45331-00-5B	HOUSING, BEARING	1	
30	6G1-45316-09-00	.BUSHING, DRIVE SHAFT	1	
31	93101-11M23-00	.OIL SEAL	2	
32	68T-45315-A0-00	.PACKING, LOWER CASING	1	
33	93210-06ME6-00	.O-RING	1	
34	97080-08025-00	BOLT	2	
35	68T-44150-00-00	SHIFT CAM ASSY	1	
36	68T-45511-10-00	SHAFT, DRIVE	1	UR L
36	68T-45511-00-00	SHAFT, DRIVE	1	UR S
37	90467-09M05-00	CLIP	1	
38	99001-07600-00	CIRCLIP	1	
39	68T-45551-00-00	PINION (13T)	1	
40	6G1-45533-00-19	SHIM (T:1.9MM)	1	UR
40	6G1-45533-00-22	SHIM (T:2.2MM)	1	UR
40	6G1-45533-00-21	SHIM (T:2.1MM)	1	UR
40	6G1-45533-00-20	SHIM (T:2.0MM)	1	UR
41	68T-45560-00-00	GEAR 1 (27T)	1	
42	664-45587-01-12	SHIM (T:0.12MM)	1	UR
42	664-45587-01-30	SHIM (T:0.30MM)	1	UR
42	664-45587-01-50	SHIM (T:0.50MM)	1	UR
42	664-45587-01-40	SHIM (T:0.40MM)	1	UR
42	664-45587-01-15	SHIM (T:0.15MM)	1	UR
42	664-45587-01-18	SHIM (T:0.18MM)	1	UR
42	664-45587-01-10	SHIM (T:0.10MM)	1	UR
43	68T-45571-00-00	GEAR 2 (27T)	1	
44	90201-15M89-00	WASHER, PLATE	1	
45	647-45567-00-00	SHIM (T:0.10MM)	1	UN
46	68T-45631-00-00	CLUTCH, DOG	1	
47	6G1-45632-00-00	PIN, CROSS	1	
48	654-45633-00-00	RING, CROSS PIN	1	

49	90501-12M05-00	SPRING, COMPRESSION	1
50	6G1-45635-00-00	PLUNGER, SHIFT	1
51	68T-45611-00-00	SHAFT, PROPELLER	1

Part Notes

F8MSHC 2004 / LOWER CASING DRIVE 1

PART NUMBER		NOTE TEXT
90430-08020-00		OEM: This part number is among the Top 100 Most Popular Marine Maintenance Parts as of March 2014.

©2014 Yamaha Motor Corporation, U.S.A. All rights reserved.

F8MSHC 2004 / LOWER CASING DRIVE 2

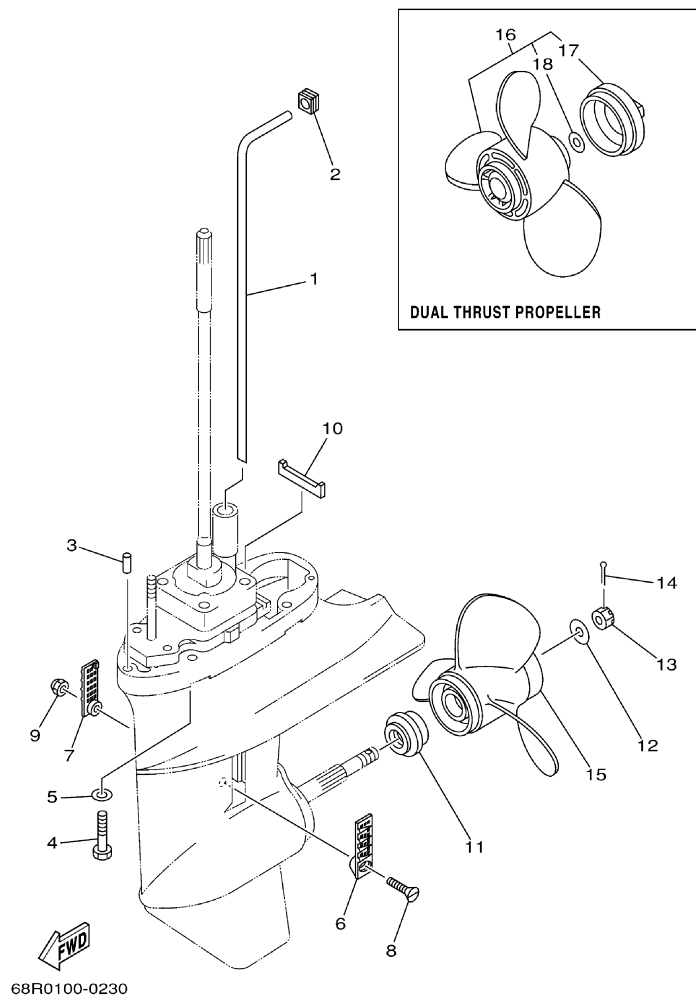

Part List

F8MSHC 2004 / LOWER CASING DRIVE 2

REF - NO	PART NUMBER	PART NAME	QUANTITY	REMARKS
1	68T-44361-10-00	TUBE, WATER 1	1	UR L
1	68T-44361-00-00	TUBE, WATER 1	1	UR S
2	63V-44365-10-00	DAMPER, WATER SEAL 1	1	
3	93604-12M07-00	PIN, DOWEL	2	
4	97075-08035-00	BOLT	4	
5	92995-08600-00	WASHER	4	
6	6G1-45214-00-00	COVER, WATER INLET 1	1	
7	6G1-45215-00-00	COVER, WATER INLET 2	1	
8	90152-05M03-00	SCREW, COUNTERSUNK	1	
9	90185-05002-00	NUT, NYLON	1	
10	63V-45375-00-00	DAMPER, SEAL	1	
11	6G1-45987-02-00	SPACER 1	1	
12	90201-10M01-00	WASHER, PLATE	1	
13	90171-10M01-00	NUT, CASTLE	1	
14	91490-30020-00	PIN. COTTER	1	
15	6G1-45941-00-EL	PROPELLER (3X8-1/2"X8-1/2"-N)	1	UR
15	6G1-45952-00-EL	PROPELLER (3X8-1/2"X8"-N)	1	UR
15	6G1-45947-00-EL	PROPELLER (3X8-1/2"X6-1/2"-N)	1	UR
15	6G1-45943-00-EL	PROPELLER (3X8-1/2"X7-1/2"-N)	1	UR
16	6G1-W4591-01-EL	PROPELLER (3X9"X7"-N)	1	UR
17	6G1-45616-01-00	.NUT, PROPELLER	1	
18	90201-10M02-00	.WASHER, PLATE	1	

F8MSHC 2004 / STEERING GUIDE

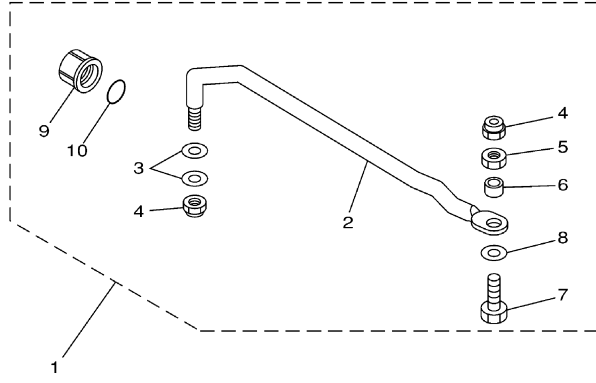

68R0300-0290

Part List

F8MSHC 2004 / STEERING GUIDE

REF - NO	PART NUMBER	PART NAME	QUANTITY	REMARKS
1	68T-61350-00-00	STEERING GUIDE ATTACH KIT	1	AP F8
2	68T-61351-00-00	.ROD, STEERING LINK	1	
3	90201-10M20-00	.WASHER, PLATE	2	
4	90185-09M01-00	.NUT, SELF-LOCKING	2	
5	90170-09M03-00	.NUT	1	
6	90387-10M42-00	.COLLAR	1	
7	6E5-61355-00-00	.BOLT	1	
8	90201-10M63-00	.WASHER, PLATE	1	
9	6E5-43145-01-00	.CAP, CLAMP BRACKET	1	
10	93210-16275-00	.O-RING	1	

F8MSHC 2004 / OPTIONAL PARTS 1

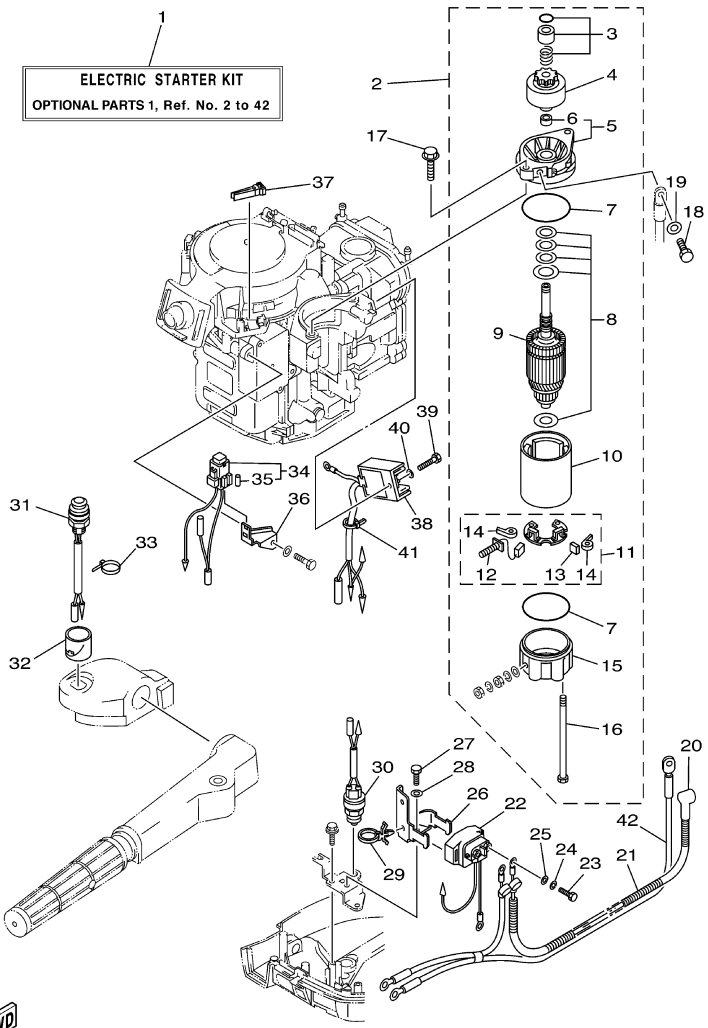

 68R3110-C270

Part List

F8MSHC 2004 / OPTIONAL PARTS 1

REF - NO	PART NUMBER	PART NAME	QUANTITY	REMARKS
1	68R-W8180-10-00	ELECTRIC STARTER KIT	1	AP F8
2	68T-81800-00-00	STARTING MOTOR ASSY	1	
3	68T-81857-00-00	.RETAINER	1	
4	689-81807-12-00	.GEAR ASSY, STARTING MOTOR	1	
5	6F5-81830-10-00	.FRONT BRACKET ASSY	1	
6	689-81831-00-00	..METAL, FRONT	1	
7	689-81847-11-00	.O-RING	2	
8	689-81809-11-00	.WASHER KIT	1	
9	689-81850-11-00	.ARMATURE ASSY	1	
10	689-81810-11-00	.STATOR ASSY	1	
11	689-81840-11-00	.BRUSH HOLDER ASSY	1	
12	689-81811-11-00	..BRUSH 1	1	
13	689-81812-11-00	..BRUSH 2	1	
14	689-81813-10-00	..SPRING, BRUSH	2	
15	689-81820-11-00	.REAR BRACKET ASSY	1	
16	689-81826-10-00	.BOLT	2	
17	90119-08M76-00	BOLT, WITH WASHER	2	
18	97095-08016-00	BOLT	1	
19	92995-08600-00	WASHER	1	
20	6G8-82117-00-00	WIRE, LEAD	1	
21	90446-10M86-00	HOSE (L140)	1	
22	68T-81940-00-00	STARTER RELAY ASSY	1	
23	97095-06010-00	BOLT	2	
24	92995-06100-00	WASHER, SPRING	2	
25	92995-06600-00	WASHER	2	
26	68T-81945-00-00	PLATE, SWITCH FITTING	1	
27	97095-06012-00	BOLT	1	
28	92995-06600-00	WASHER	1	
29	90465-12M56-00	CLAMP	1	
30	6F5-82540-00-00	NEUTRAL SWITCH ASSY	1	
31	68T-81870-00-00	STARTING SWITCH ASSY	1	
32	68T-81821-00-00	COVER, SWITCH	1	
33	90465-11M10-00	CLAMP	1	
34	68T-82150-00-00	FUSE HOLDER ASSY	1	
35	66V-82151-00-00	.FUSE (10A-BL)	2	
36	68T-82171-00-00	STAY, FUSE BOX	1	
37	67F-2812A-00-00	.PULLER, FUSE	1	
38	68T-81960-00-00	RECTIFIER & REGULATOR ASSY	1	
39	97095-06012-00	BOLT	1	
40	92995-06600-00	WASHER	1	
41	90465-11M10-00	CLAMP	1	
42	68T-82105-00-00	BATTERY CABLE (L: 2.1M)	1	

F8MSHC 2004 / OPTIONAL PARTS 2

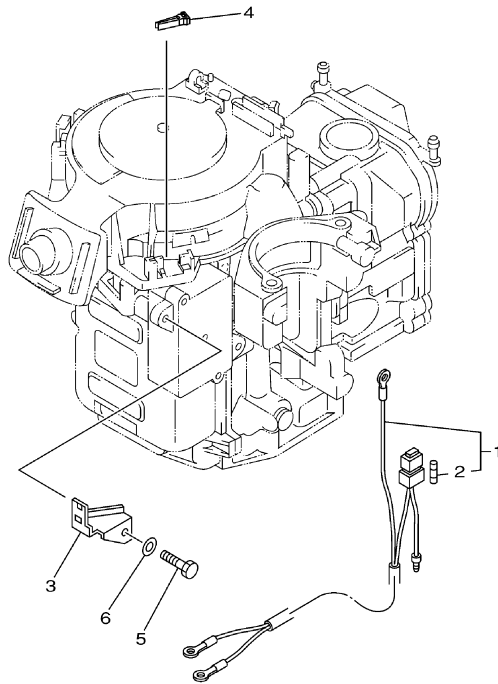

68R1100-2280

Part List

F8MSHC 2004 / OPTIONAL PARTS 2

REF - NO	PART NUMBER	PART NAME	QUANTITY	REMARKS
1	68T-81949-00-00	WIRE, LEAD	1	AP
2	66V-82151-00-00	.FUSE (10A-BL)	2	
3	68T-82171-00-00	STAY, FUSE BOX	1	AP
4	67F-2812A-00-00	.PULLER, FUSE	1	AP
5	97095-06012-00	BOLT	1	AP
6	92995-06600-00	WASHER	1	AP

F8MSHC 2004 / OPTIONAL PARTS 3

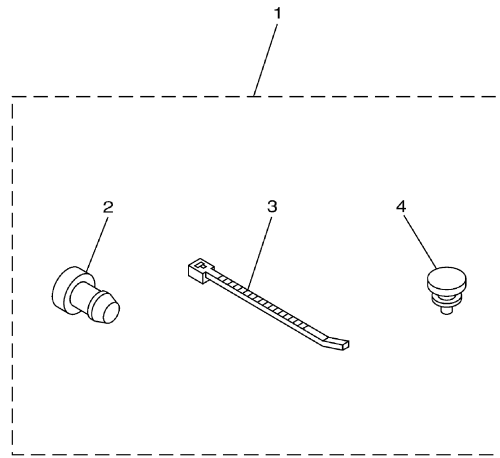

68R1100-2290

Part List

F8MSHC 2004 / OPTIONAL PARTS 3

REF - NO	PART NUMBER	PART NAME	QUANTITY	REMARKS
1	69G-W1257-00-00	FLUSHING ELIMINATION KIT	1	AP
2	90338-07M16-00	.PLUG	1	
3	90465-11M10-00	.CLAMP	1	
4	90480-06M19-00	.GROMMET	2	

F8MSHC 2004 / REPAIR KIT 1

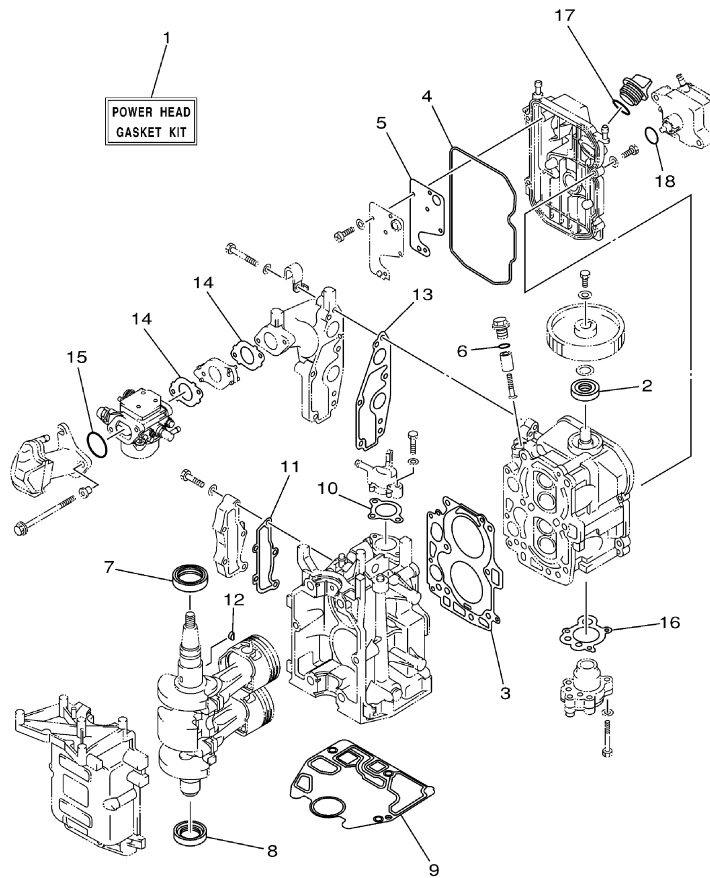



68R0100-0250

Part List

F8MSHC 2004 / REPAIR KIT 1

REF - NO	PART NUMBER	PART NAME	QUANTITY	REMARKS
1	68T-W0001-00-00	POWER HEAD GASKET KIT	1	
2	93102-18M21-00	.OIL SEAL	1	
3	68T-11181-00-00	.GASKET, CYLINDER HEAD 1	1	
4	68T-11356-00-00	.SEAL, CYLINDER 2	1	
5	68T-11169-A0-00	.GASKET, BREATHER COVER	1	
6	93210-13M63-00	.O-RING	1	
7	93102-30M22-00	.OIL SEAL	1	
8	93101-25M69-00	.OIL SEAL	1	
9	68T-11351-00-00	.GASKET, CYLINDER	1	
10	6G8-12414-A0-00	.GASKET, COVER	1	
11	68T-41114-A0-00	.GASKET, EXHAUST OUTER COVER	1	
12	90280-03M01-00	.KEY, WOODRUFF	1	
13	68T-13645-00-00	.GASKET, MANIFOLD 1	1	
14	68T-13646-A0-00	.GASKET, MANIFOLD 2	2	
15	93210-31MJ5-00	.O-RING	1	
16	68T-13329-00-00	.GASKET, PUMP COVER	1	
17	93210-24M79-00	.O-RING	1	
18	93210-20M65-00	.O-RING	1	

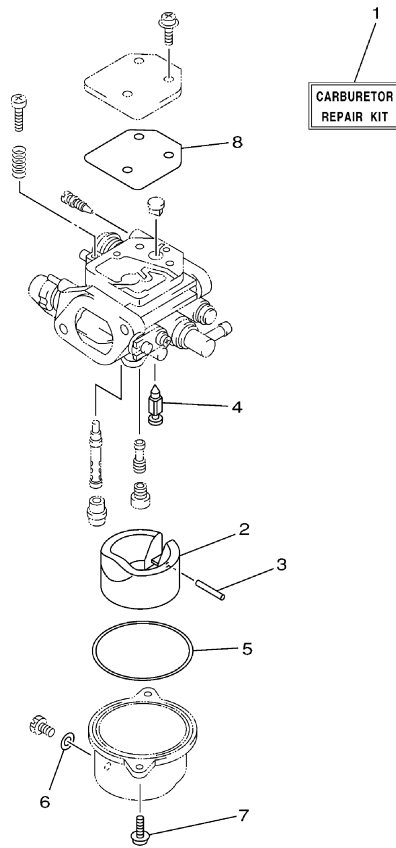
F8MSHC 2004 / REPAIR KIT 2



68R0100-0260

Part List

F8MSHC 2004 / REPAIR KIT 2

REF - NO	PART NUMBER	PART NAME	QUANTITY	REMARKS
1	68T-W0093-00-00	CARBURETOR REPAIR KIT	1	
2	68T-14385-00-00	.FLOAT	1	
3	67D-14386-00-00	.PIN, FLOAT	1	
4	68T-14546-00-00	.VALVE, NEEDLE	1	
5	67D-14984-00-00	.GASKET, FLOAT CHAMBER	1	
6	6J8-14959-00-00	.GASKET	1	
7	97980-04112-00	.SCREW, WITH WASHER	2	
8	67D-14536-00-00	.GASKET	1	

F8MSHC 2004 / REPAIR KIT 3

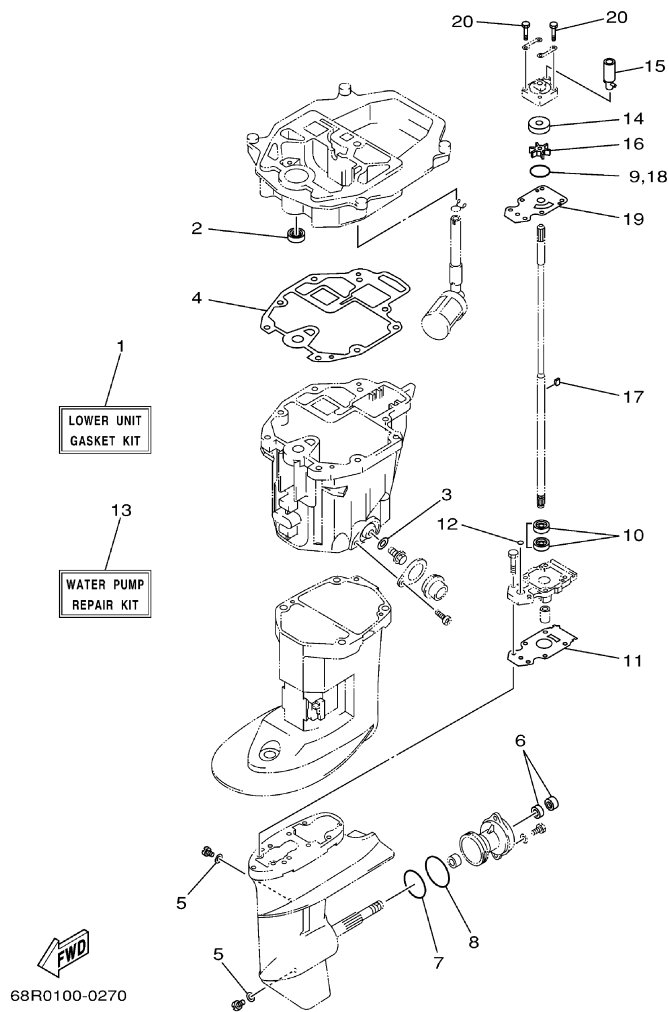

©2014 Yamaha Motor Corporation, U.S.A. All rights reserved.

Part List

F8MSHC 2004 / REPAIR KIT 3

REF - NO	PART NUMBER	PART NAME	QUANTITY	REMARKS
1	68T-W0001-20-00	LOWER UNIT GASKET KIT	1	
2	93101-12M70-00	.OIL SEAL	1	
3	90430-10M11-00	.GASKET	1	
4	68T-13475-00-00	.GASKET	1	
5	90430-08020-00	.GASKET	2	
6	93101-15074-00	.OIL SEAL	2	
7	93210-49046-00	.O-RING	1	
8	93210-53M08-00	.O-RING	1	
9	93210-44398-00	.O-RING	1	
10	93101-11M23-00	.OIL SEAL	2	
11	68T-45315-A0-00	.PACKING, LOWER CASING	1	
12	93210-06ME6-00	.O-RING	1	
13	68T-W0078-00-00	WATER PUMP REPAIR KIT	1	
14	63V-44322-00-00	.INSERT, CARTRIDGE	1	
15	68T-44366-00-00	.DAMPER, WATER SEAL 2	1	
16	68T-44352-00-00	.IMPELLER	1	
17	664-44338-00-00	.KEY, WOODRUFF	1	
18	93210-44398-00	.O-RING	1	
19	68T-44323-00-00	.OUTER PLATE, CARTRIDGE	1	
20	97080-08045-00	.BOLT	4	

Part Notes

F8MSHC 2004 / REPAIR KIT 3

PART NUMBER	NOTE TEXT
90430-08020-00 	OEM: This part number is among the Top 100 Most Popular Marine Maintenance Parts as of March 2014.

©2014 Yamaha Motor Corporation, U.S.A. All rights reserved.

©2014 Yamaha Motor Corporation, U.S.A. All rights reserved.