

F4MSHB 2003 / TOP COWLING

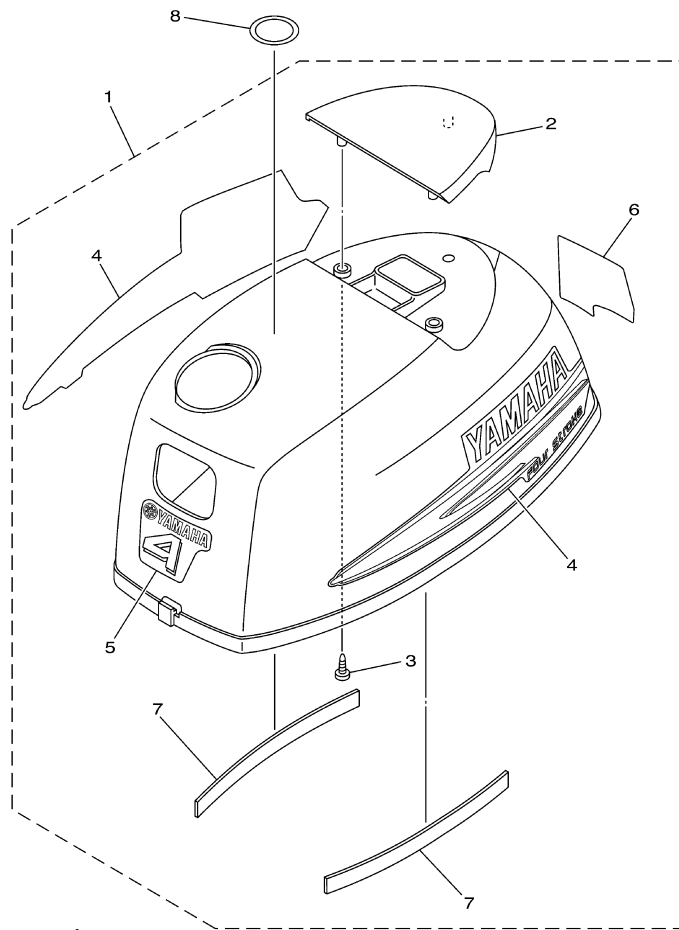

68D2010-2010

Part List

F4MSHB 2003 / TOP COWLING

REF - NO	PART NUMBER	PART NAME	QUANTITY	REMARKS
1	68D-G2610-40-4D	TOP COWLING ASSY	1	
2	68D-G2613-01-00	.MOLDING, AIR DUCT	1	
3	97780-40012-00	.SCREW, TAPPING	3	
4	68D-WG070-00-00	.GRAPHIC SET	1	
5	68D-G2677-00-00	.GRAPHIC, FRONT	1	
6	68D-G2678-00-00	.GRAPHIC, REAR	1	
7	68D-42662-00-00	.DAMPER	2	
8	67F-13434-02-00	LABEL, CAUTION	1	

F4MSHB 2003 / CYLINDER CRANKCASE 1

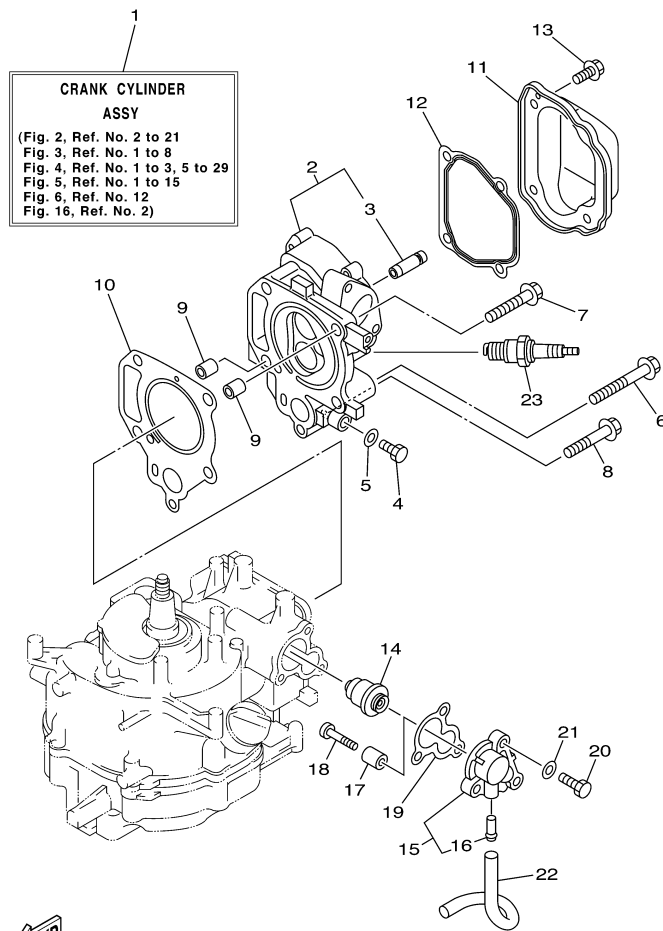

68D3100-3020

Part List

F4MSHB 2003 / CYLINDER CRANKCASE 1

REF - NO	PART NUMBER	PART NAME	QUANTITY	REMARKS
1	68D-WE090-10-4D	CRANK CYLINDER ASSY	1	
2	68D-E1111-10-94	HEAD, CYLINDER 1	1	
3	67D-11133-10-00	.GUIDE, VALVE 1	2	
4	97095-08014-00	BOLT	1	
5	90430-08800-00	.GASKET	1	
6	90105-08M36-00	BOLT, FLANGE	3	
7	90105-08046-00	BOLT, FLANGE	1	
8	90105-06M25-00	BOLT, FLANGE	1	
9	99510-10114-00	PIN, DOWEL	2	
10	67D-11181-A0-00	.GASKET, CYLINDER HEAD 1	1	
11	67D-11191-00-00	COVER, CYLINDER HEAD 1	1	
12	68D-E1193-A0-00	.GASKET, HEAD COVER 1	1	
13	90105-06M14-00	BOLT FLANGE	4	
14	66M-12411-00-00	THERMOSTAT	1	
15	68D-E2413-00-9M	COVER, THERMOSTAT	1	
16	650-24378-00-00	.PIPE, JOINT 4	1	
17	68D-E1325-00-00	ANODE	1	
18	97880-05025-00	SCREW, PAN HEAD	1	
19	68D-E2414-A0-00	.GASKET, COVER	1	
20	97095-06020-00	BOLT	3	
21	92995-06600-00	WASHER	3	
22	90445-09807-00	HOSE (L180)	1	
23	NGK-BR6HS-00-00	PLUG, SPARK (NGK BR6HS)	1	

F4MSHB 2003 / CRANKSHAFT PISTON

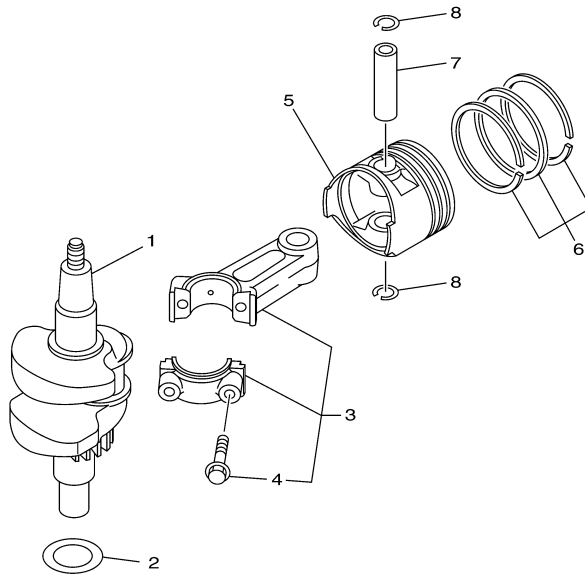

67D0010-8030

Part List

F4MSHB 2003 / CRANKSHAFT PISTON

REF - NO	PART NUMBER	PART NAME	QUANTITY	REMARKS
1	67D-11400-00-00	CRANKSHAFT ASSY	1	
2	90201-266P2-00	WASHER, PLATE	1	
3	67D-11650-00-00	CONNECTING ROD ASSY	1	
4	67D-11654-00-00	.BOLT, CONNECTING ROD	2	
5	68D-E1631-00-96	PISTON (STD)	1	
5	68D-E1636-00-00	PISTON (0.50MM O/S)	1	AP
5	68D-E1635-00-00	PISTON (0.25MM O/S)	1	AP
6	68D-E1603-00-00	PISTON RING SET (STD)	1	
6	68D-E1605-00-00	PISTON RING SET (0.50MM O/S)	1	AP
6	68D-E1604-00-00	PISTON RING SET (0.25MM O/S)	1	AP
7	68D-E1633-00-00	PIN, PISTON	1	
8	93450-14088-00	CIRCLIP	2	

F4MSHB 2003 / CYLINDER CRANKCASE 2

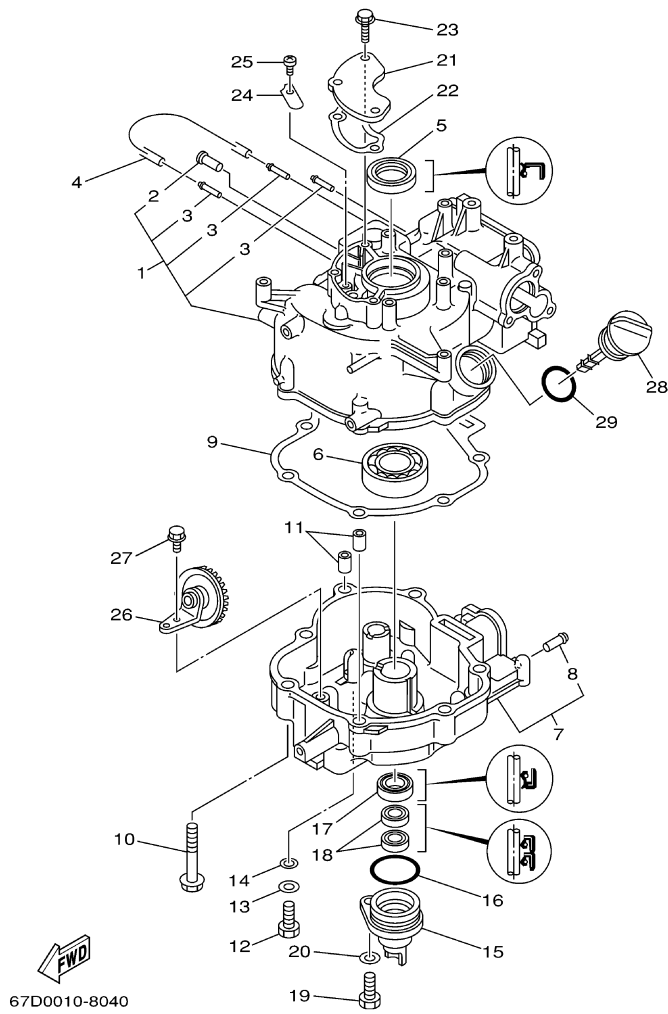

©2014 Yamaha Motor Corporation, U.S.A. All rights reserved.

Part List

F4MSHB 2003 / CYLINDER CRANKCASE 2

REF - NO	PART NUMBER	PART NAME	QUANTITY	REMARKS
1	68D-E1311-01-94	CYLINDER 1	1	
2	650-24378-00-00	.PIPE, JOINT 4	1	
3	6H1-14485-00-00	.PIPE, JOINT	3	
4	90445-07806-00	HOSE (L167)	1	
5	93102-25090-00	.OIL SEAL	1	
6	93306-205YD-00	BEARING	1	
7	68D-E5111-00-94	CRANKCASE 1	1	
8	650-24378-00-00	.PIPE, JOINT 4	1	
9	68D-11351-A0-00	.GASKET, CYLINDER	1	
10	97575-08550-00	BOLT, WITH WASHER	7	
11	99510-10114-00	PIN, DOWEL	2	
12	97095-08020-00	BOLT	1	
13	92995-08600-00	WASHER	1	
14	90201-08818-00	WASHER, PLATE	1	
15	68D-E5396-00-5B	HOUSING, OIL SEAL	1	
16	93210-35537-00	O-RING	1	
17	93102-20108-00	OIL SEAL	1	
18	93102-10004-00	.OIL SEAL	2	
19	97095-08020-00	BOLT	1	
20	92995-08600-00	WASHER	1	
21	68D-E1168-00-00	COVER, BREATHER	1	
22	68D-E1169-A0-00	.GASKET, BREATHER COVER	1	
23	90119-06M80-00	BOLT, WITH WASHER	3	
24	68D-E5346-00-00	BREATHER 1	1	
25	98503-04006-00	SCREW, PAN HEAD	1	
26	68D-E3102-00-00	GEAR UNIT ASSY	1	
27	95817-06012-00	BOLT, FLANGE	1	
28	68D-E5362-00-00	PLUG, OIL LEVEL	1	
29	93210-24M79-00	.O-RING	1	

F4MSHB 2003 / VALVE

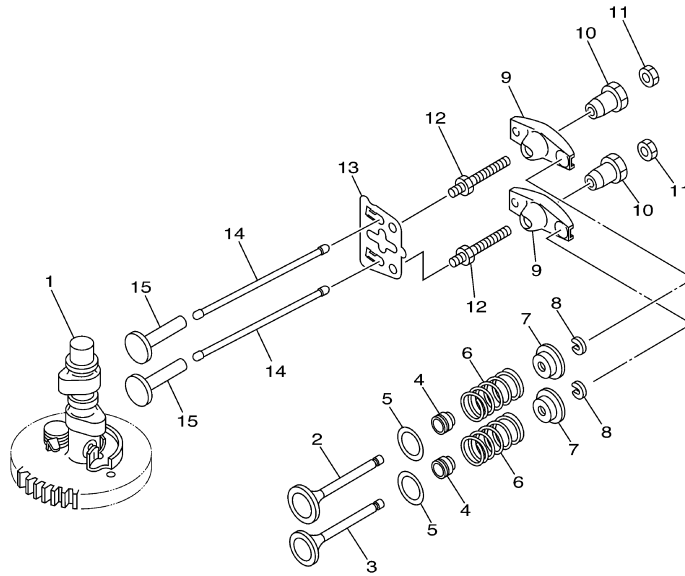

68D3010-3050

©2014 Yamaha Motor Corporation, U.S.A. All rights reserved.

Part List

F4MSHB 2003 / VALVE

REF - NO	PART NUMBER	PART NAME	QUANTITY	REMARKS
1	68D-E2170-00-00	CAMSHAFT ASSY 1	1	
2	67D-12111-00-00	VALVE, INTAKE	1	
3	67D-12121-00-00	VALVE, EXHAUST	1	
4	51Y-12119-00-00	SEAL, VALVE STEM	2	
5	68T-12116-00-00	SEAT, VALVE SPRING	2	
6	68D-E2113-00-00	SPRING, VALVE INNER	2	
7	7NJ-12117-00-00	RETAINER, VALVE SPRING	2	
8	7NJ-12118-00-00	LOCK, VALVE SPRING RETAINER	2	
9	67D-12151-00-00	ARM, VALVE ROCKER	2	
10	7FK-12165-00-00	PIVOT, ROCKER ARM	2	
11	7FK-12158-00-00	NUT, LOCK	2	
12	67D-12157-00-00	BOLT	2	
13	68D-E2155-00-00	GUIDE, PUSH ROD	1	
14	67D-12154-00-00	ROD, VALVE PUSH	2	
15	JA9-12153-00-00	LIFTER, VALVE	2	

F4MSHB 2003 / INTAKE

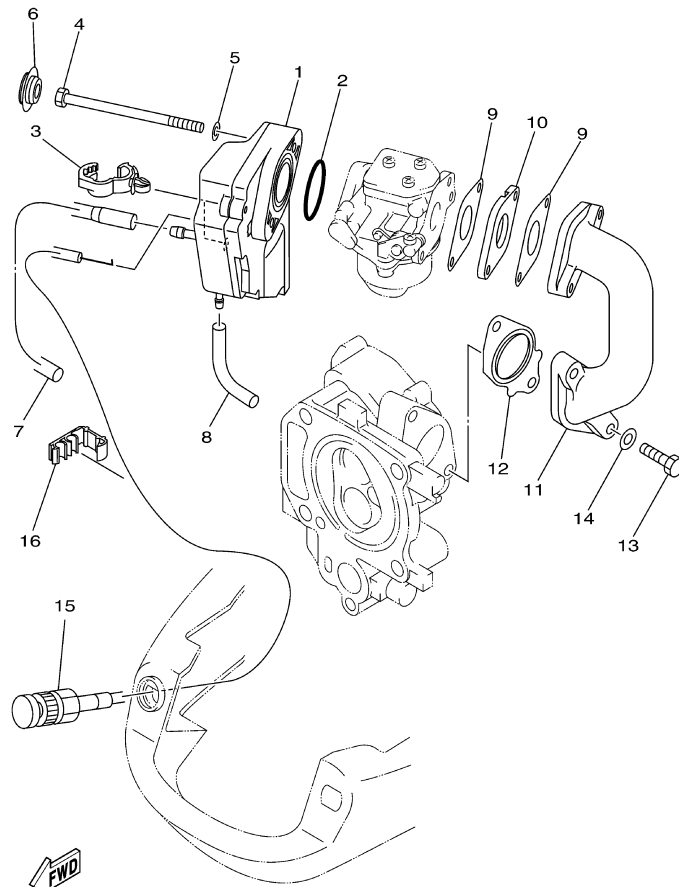

67D0010-8060

Part List

F4MSHB 2003 / INTAKE

REF - NO	PART NUMBER	PART NAME	QUANTITY	REMARKS
1	68D-E4440-00-00	SILENCER ASSY, INTAKE	1	
2	93210-31MJ5-00	.O-RING	1	
3	90464-13249-00	CLAMP	1	
4	97095-06090-00	BOLT	2	
5	92995-06600-00	WASHER	2	
6	90480-18M74-00	GROMMET	2	
7	68D-F4314-00-00	PIPE 4	1	
8	90445-07805-00	HOSE (L70)	1	
9	68D-E3646-A0-00	.GASKET, MANIFOLD 2	2	
10	68D-E3647-00-00	GASKET, MANIFOLD 3	1	
11	68D-E3641-00-94	MANIFOLD 1	1	
12	68D-E3645-A0-00	.GASKET, MANIFOLD 1	1	
13	97095-06025-00	BOLT	2	
14	92995-06600-00	WASHER	2	
15	68D-F6330-00-00	STARTER CABLE ASSY	1	
16	90464-05122-00	CLAMP	1	

F4MSHB 2003 / CARBURETOR

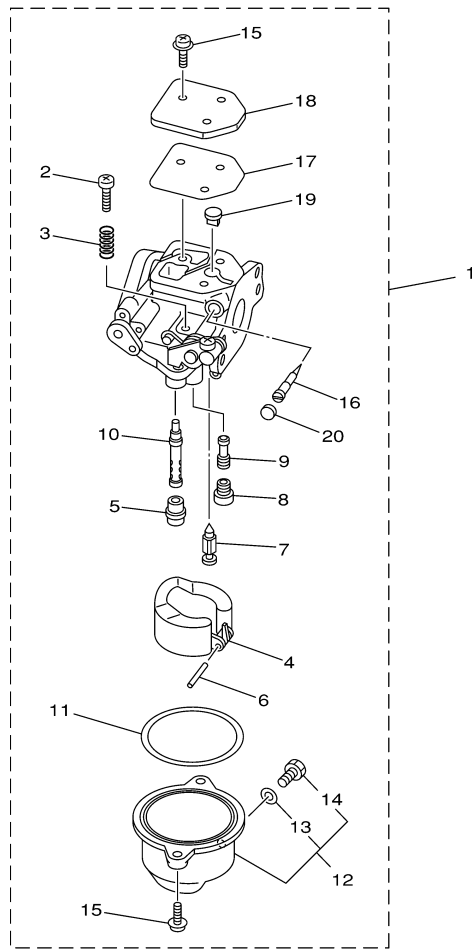

67D0100-8070

Part List

F4MSHB 2003 / CARBURETOR

REF - NO	PART NUMBER	PART NAME	QUANTITY	REMARKS
1	67D-14301-11-00	CARBURETOR ASSY 1	1	
2	6E5-14321-00-00	.SCREW, THROTTLE	1	
3	6J8-14334-00-00	.SPRING, THROTTLE	1	
4	68T-14385-00-00	.FLOAT	1	
5	67D-14966-00-00	.RUBBER CAP	1	
6	67D-14386-00-00	.PIN, FLOAT	1	
7	67D-14546-00-00	.VALVE, NEEDLE	1	
8	67D-1492E-34-00	.JET, MAIN (#68)	1	
9	67D-1492F-18-00	.JET, AIR SLOW (#36)	1	
10	67D-1492A-00-00	.NOZZLE, MAIN	1	
11	67D-14984-00-00	.GASKET, FLOAT CHAMBER	1	
12	67D-14981-00-00	.BODY, FLOAT CHAMBER	1	
13	6J8-14959-00-00	.GASKET	1	
14	66T-14991-00-00	.PLUG, DRAIN	1	
15	97980-04112-00	.SCREW, WITH WASHER	5	
16	67D-14323-00-00	.SCREW, AIR ADJUSTING	1	
17	67D-14536-00-00	.GASKET	1	
18	67D-14527-00-00	.PLATE	1	
19	67D-14126-00-00	.PLUG	1	
20	67D-1432A-00-00	.PLUG	1	

F4MSHB 2003 / FUEL 1

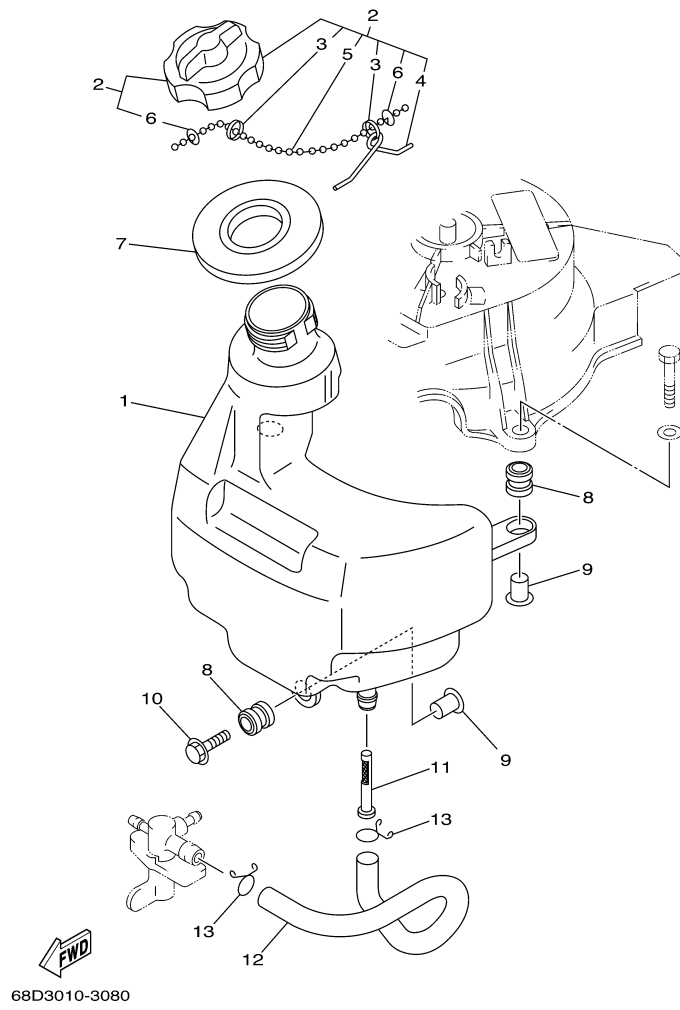

©2014 Yamaha Motor Corporation, U.S.A. All rights reserved.

Part List

F4MSHB 2003 / FUEL 1

REF - NO	PART NUMBER	PART NAME	QUANTITY	REMARKS
1	68D-F4111-00-00	TANK, FUEL	1	
2	67D-24610-02-00	CAP ASSY	1	
3	90501-10260-00	.SPRING, COMPRESSION	2	
4	624-24634-00-00	.HOOK, CHAIN BALL	1	
5	69M-24633-00-00	.CHAIN, BALL	1	
6	6H1-21757-00-00	.WASHER, SPECIAL 1	2	
7	6L5-24641-00-00	GASKET, CAP 1	1	
8	6A0-82317-00-00	DAMPER, IGNITION COIL	3	
9	624-42542-00-00	PIPE	3	
10	90119-06M88-00	BOLT, WITH WASHER	1	
11	6L5-24251-00-00	STRAINER 1	1	
12	68D-F4311-00-00	PIPE, FUEL 1	1	
13	90467-13M13-00	CLIP	2	

F4MSHB 2003 / FUEL 2

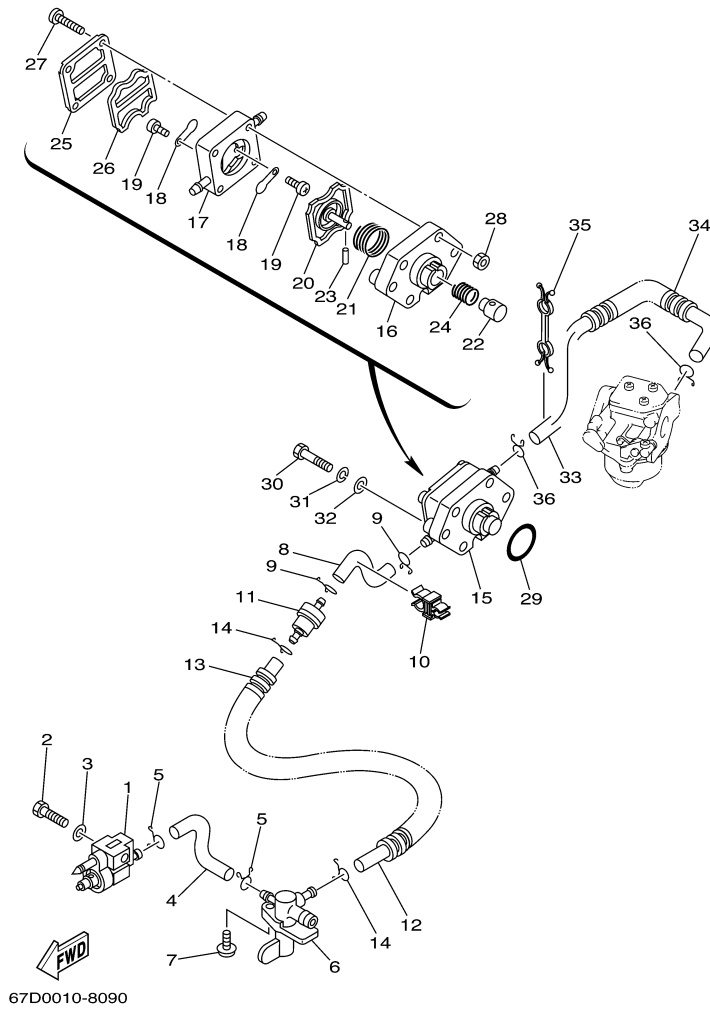

©2014 Yamaha Motor Corporation, U.S.A. All rights reserved.

Part List

F4MSHB 2003 / FUEL 2

REF - NO	PART NUMBER	PART NAME	QUANTITY	REMARKS
1	6G1-24304-02-00	FUEL PIPE JOINT COMP. 1	1	
2	97095-06025-00	BOLT	1	
3	92995-06600-00	WASHER	1	
4	68D-F4312-00-00	PIPE 2	1	
5	90467-09M09-00	CLIP	2	
6	68D-F4500-00-00	FUEL COCK ASSY 1	1	
7	90159-06M10-00	SCREW, WITH WASHER	1	
8	68D-F4313-00-00	PIPE 3	1	
9	90467-09M09-00	CLIP	2	
10	90464-10M52-00	CLAMP	1	
11	646-24251-02-00	.STRAINER 1	1	
12	90445-10804-00	HOSE (L140)	1	
13	90446-14M12-00	HOSE	1	
14	90467-09M09-00	CLIP	2	
15	67D-24410-02-00	FUEL PUMP ASSY	1	
16	67D-24412-00-00	.BODY 1	1	
17	67D-24413-02-00	.BODY 2	1	
18	6A0-24421-01-00	.VALVE, CHECK	2	
19	6E7-14325-00-00	.SCREW, PAN HEAD	2	
20	67D-24411-00-00	.DIAPHRAGM	1	
21	67D-24423-00-00	.SPRING, DIAPHRAGM	1	
22	67D-13131-00-00	.PLUNGER	1	
23	66M-24374-00-00	.PIN	1	
24	67D-24454-00-00	.SPRING	1	
25	67D-24414-01-00	.BODY 3	1	
26	66M-24471-00-00	.DIAPHRAGM	1	
27	67D-24444-00-00	.SCREW	4	
28	95380-04600-00	.NUT	4	
29	93210-27ME3-00	O-RING	1	
30	97095-06030-00	BOLT	2	
31	92995-06100-00	WASHER, SPRING	2	
32	92995-06600-00	WASHER	2	
33	90445-10805-00	HOSE (L250)	1	
34	90446-14M12-00	HOSE	1	
35	90464-10M53-00	CLAMP	1	
36	90467-09M09-00	CLIP	2	

Part Notes

F4MSHB 2003 / FUEL 2

PART NUMBER	NOTE TEXT
646-24251-02-00 	OEM: This part number is among the Top 100 Most Popular Marine Maintenance Parts as of March 2014.

©2014 Yamaha Motor Corporation, U.S.A. All rights reserved.

F4MSHB 2003 / STARTER

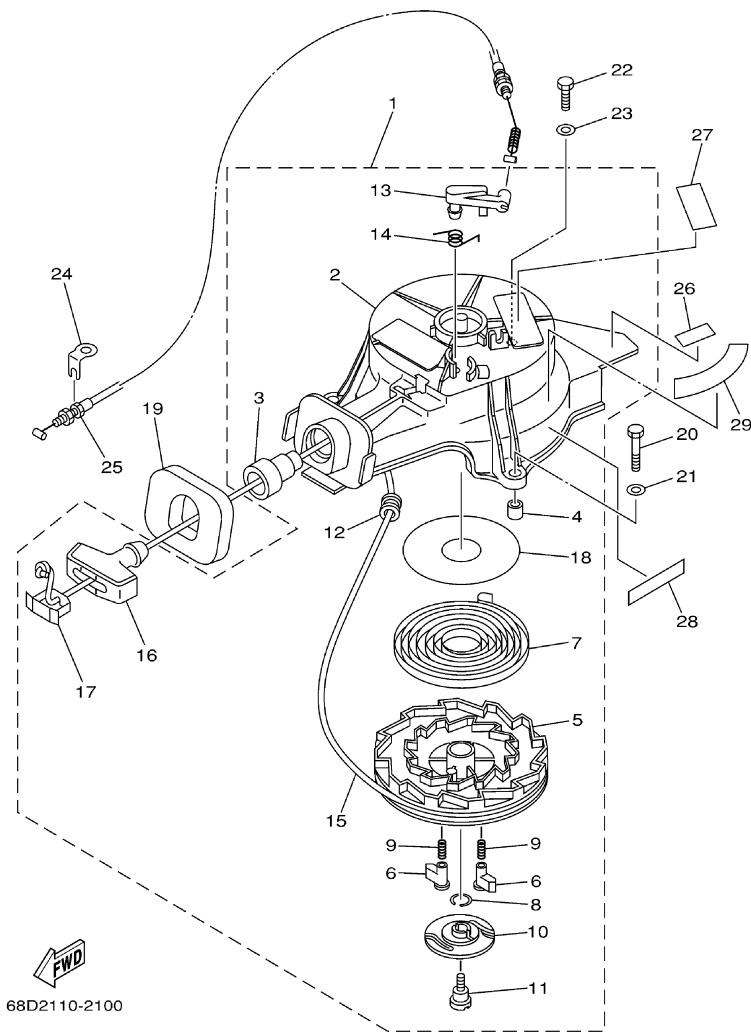

*15: CUT FROM 50M ROLLS, PART NO. 90890-44372. CUT TO 1.8M LENGTH.

Part List

F4MSHB 2003 / STARTER

REF - NO	PART NUMBER	PART NAME	QUANTITY	REMARKS
1	67D-15710-00-00	STARTER ASSY	1	
2	67D-15711-00-00	.CASE, STARTER	1	
3	63V-15795-01-00	.GUIDE, ROPE	1	
4	67D-15764-00-00	.COLLAR 1	3	
5	67D-15714-00-00	.DRUM, SHEAVE	1	
6	67D-15741-00-00	.PAWL, DRIVE	2	
7	67D-15713-00-00	.SPRING, STARTER	1	
8	67D-15705-00-00	.SPRING, DRIVE PAWL	1	
9	67D-15767-00-00	.SPRING	2	
10	67D-15735-00-00	.GUIDE, CAM	1	
11	67D-15793-00-00	.SCREW	1	
12	63V-15764-00-00	.COLLAR 1	1	
13	67D-15794-00-00	.STOPPER	1	
14	67D-15734-00-00	.SPRING, RETURN	1	
15	90890-44372-00	STARTER ROPE	1	UNAVAILABLE - OBTAIN LOCALLY - CUT TO 1.8M LENGTH
16	6G1-15755-00-00	.HANDLE, STARTER	1	
17	6G1-15779-00-00	.COVER	1	
18	67D-15739-00-00	.WASHER, THRUST	1	
19	67D-15762-00-00	SEAL, RUBBER 2	1	
20	97095-06035-00	BOLT	2	
21	92995-06600-00	WASHER	2	
22	97095-06020-00	BOLT	1	
23	92995-06600-00	WASHER	1	
24	67D-15772-00-00	STAY 2	1	
25	67D-15770-00-00	CABLE COMP., STARTER STOP	1	
26	67D-42791-10-00	MARK 1	1	
27	6A1-83625-41-00	MARK 5	1	
28	68D-13437-40-00	MARK, CAUTION	1	
29	67D-14427-40-00	LABEL, INSTRUCTION	1	

F4MSHB 2003 / GENERATOR

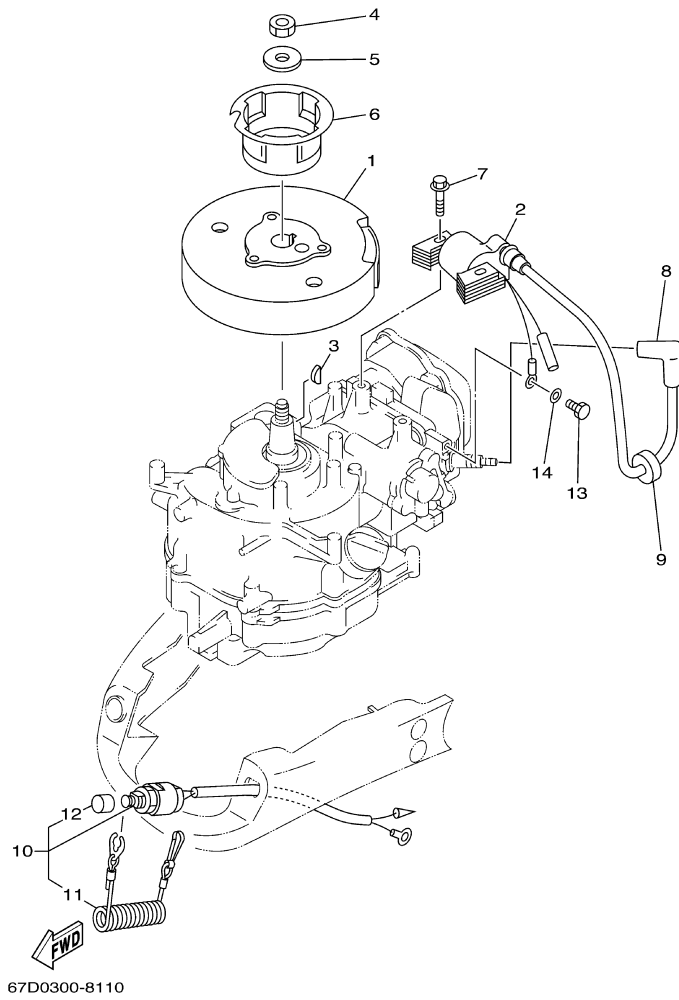

©2014 Yamaha Motor Corporation, U.S.A. All rights reserved.

Part List

F4MSHB 2003 / GENERATOR

REF - NO	PART NUMBER	PART NAME	QUANTITY	REMARKS
1	67D-85650-00-00	ROTOR ASSY	1	
2	67D-85640-00-00	T.C.I. UNIT ASSY	1	
3	90280-04M06-00	KEY, WOODRUFF	1	
4	90170-10M33-00	NUT	1	
5	90201-105A2-00	WASHER, PLATE	1	
6	67D-15723-00-00	PULLEY, STARTER	1	
7	90105-06M24-00	BOLT, FLANGE	2	
8	6E3-82370-21-00	PLUG CAP ASSY	1	
9	90480-25161-00	GROMMET	1	
10	67D-82575-00-00	ENGINE STOP SWITCH ASSY	1	
11	682-82556-00-00	.LANYARD, STOP SWITCH	1	
12	689-8257Y-00-00	.CAP	1	
13	97095-06012-00	BOLT	1	
14	92995-06600-00	WASHER	1	

Part Notes

F4MSHB 2003 / GENERATOR

PART NUMBER	NOTE TEXT
682-82556-00-00 	OEM: This part number is among the Top 100 Most Popular Marine Maintenance Parts as of March 2014.

©2014 Yamaha Motor Corporation, U.S.A. All rights reserved.

F4MSHB 2003 / BOTTOM COWLING

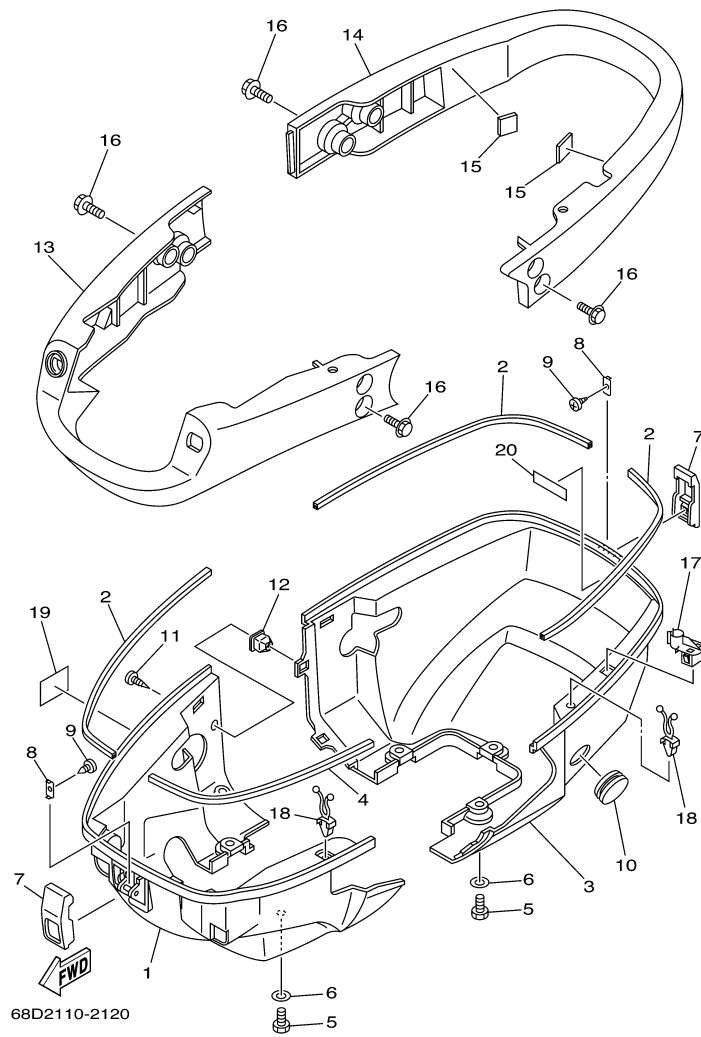

©2014 Yamaha Motor Corporation, U.S.A. All rights reserved.

Part List

F4MSHB 2003 / BOTTOM COWLING

REF - NO	PART NUMBER	PART NAME	QUANTITY	REMARKS
1	68D-G2711-01-00	COWLING, BOTTOM 1	1	
2	68D-G2628-00-00	SEAL	3	
3	68D-G2712-01-00	COWLING, BOTTOM 2	1	
4	68D-G2629-00-00	SEAL	1	
5	97095-06016-00	BOLT	6	
6	92995-06600-00	WASHER	6	
7	6L5-42647-00-00	HOLDER, CLAMP BAND	2	
8	6L5-42823-00-00	PLATE, STOP	2	
9	90167-03M02-00	SCREW, TAPPING	2	
10	90480-22M72-00	GROMMET	1	
11	90161-05001-00	SCREW, TAPPING	3	
12	90480-10004-00	GROMMET	3	
13	68D-G2731-00-00	CARRYING HANDLE	1	
14	68D-G2735-00-00	PROTECTOR	1	
15	67D-42662-00-00	DAMPER	2	
16	90119-06M79-00	BOLT, WITH WASHER	8	
17	90464-07M50-00	CLAMP	1	
18	90464-07078-00	CLAMP	2	
19	67D-13444-40-00	MARK	1	
20	68D-E2138-40-00	MARK, CAUTION	1	

F4MSHB 2003 / STEERING

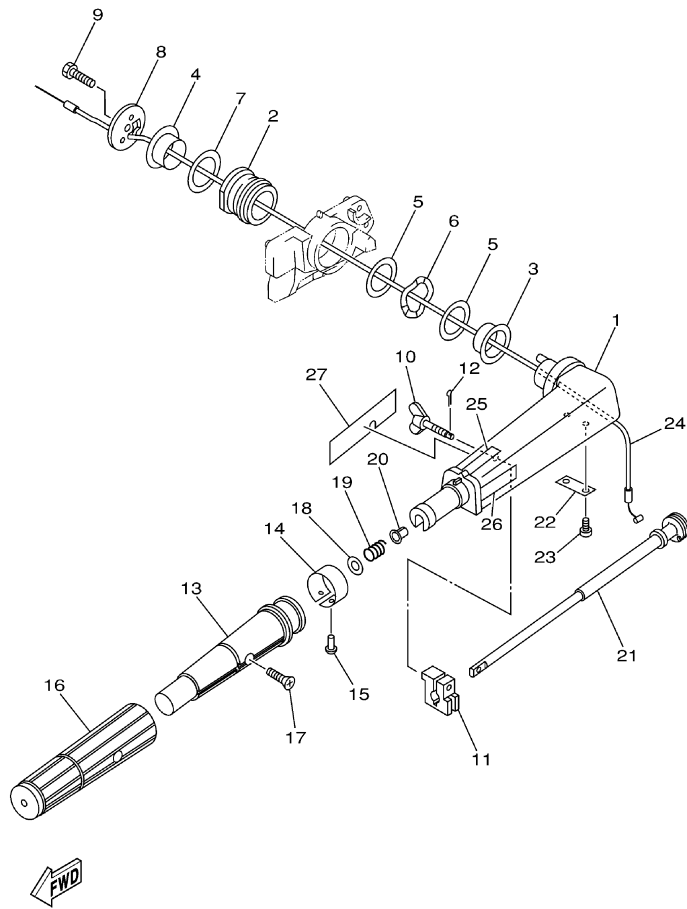

68D2110-2130

Part List

F4MSHB 2003 / STEERING

REF - NO	PART NUMBER	PART NAME	QUANTITY	REMARKS
1	68D-G2111-00-4D	HANDLE, STEERING	1	
2	67D-42129-00-00	BUSHING, RUBBER	1	
3	68D-G2171-00-00	BUSHING	1	
4	68D-G2172-00-00	BUSHING 2	1	
5	68D-G2181-00-00	WASHER	2	
6	69M-G2188-00-00	WASHER, WAVE	1	
7	68D-G2182-00-00	WASHER 2	1	
8	68D-G2131-01-00	COVER, HANDLE STEERING	1	
9	97075-08025-00	BOLT	1	
10	6G1-42125-01-00	BOLT, FRICTION ADJUSTING	1	
11	6N0-G2126-00-00	FRICTION, STEERING HANDLE GRIP	1	
12	91490-16010-00	PIN. COTTER	1	
13	68D-G2119-00-00	GRIP, STEERING HANDLE	1	
14	68D-G2137-00-00	INDICATOR, THROTTLE	1	
15	90269-02M09-00	RIVET	1	
16	67D-42177-00-00	RUBBER, HANDLE	1	
17	90149-05M13-00	SCREW	1	
18	92903-10600-00	WASHER, PLATE	1	
19	90501-23215-00	SPRING, COMPRESSION	1	
20	90386-08032-00	BUSH	1	
21	69M-G2138-00-00	LEVER, THROTTLE	1	
22	68D-G2159-00-00	STAY	1	
23	97885-05012-00	SCREW, PAN HEAD	2	
24	68D-F6301-00-00	THROTTLE CABLE ASSY	1	
25	6E0-83627-41-00	LABEL, CAUTION 7	1	
26	6A1-2415A-41-00	LABEL, CAUTION	1	
27	68D-E571Y-40-00	MARK, CAUTION	1	

F4MSHB 2003 / CONTROL

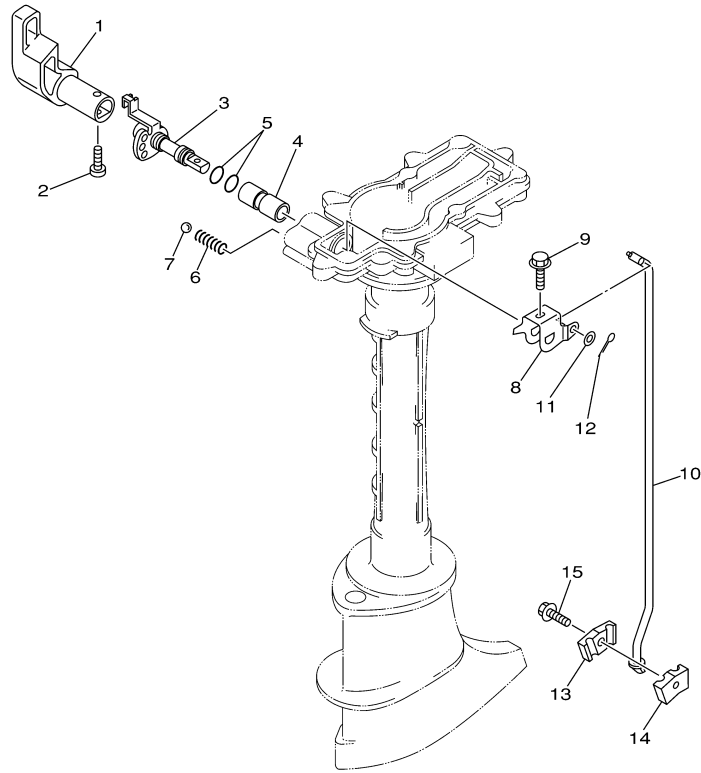

67D0010-0141

©2014 Yamaha Motor Corporation, U.S.A. All rights reserved.

Part List

F4MSHB 2003 / CONTROL

REF - NO	PART NUMBER	PART NAME	QUANTITY	REMARKS
1	68D-G4111-00-00	HANDLE, GEAR SHIFT	1	
2	98680-05520-00	SCREW, OVAL HEAD	1	
3	68D-G4119-00-00	SHAFT, CHANGE	1	
4	68D-G4122-01-00	BUSHING, SHIFT ROD LEVER	1	
5	93210-09350-00	O-RING	2	
6	90501-12274-00	SPRING, COMPRESSION	1	
7	93505-16024-00	BALL	1	
8	68D-G4121-00-00	LEVER, SHIFT ROD	1	
9	90119-05M04-00	BOLT, WITH WASHER	1	
10	67D-44143-01-00	ROD, SHIFT	1	
11	92990-05600-00	WASHER, PLATE	1	
12	91490-16010-00	PIN. COTTER	1	
13	68D-G4145-00-00	CONNECTOR, SHIFT ROD	1	
14	68D-G4146-00-00	CONNECTOR, SHIFT ROD	1	
15	90119-06ME0-00	BOLT, WITH WASHER	1	

F4MSHB 2003 / BRACKET

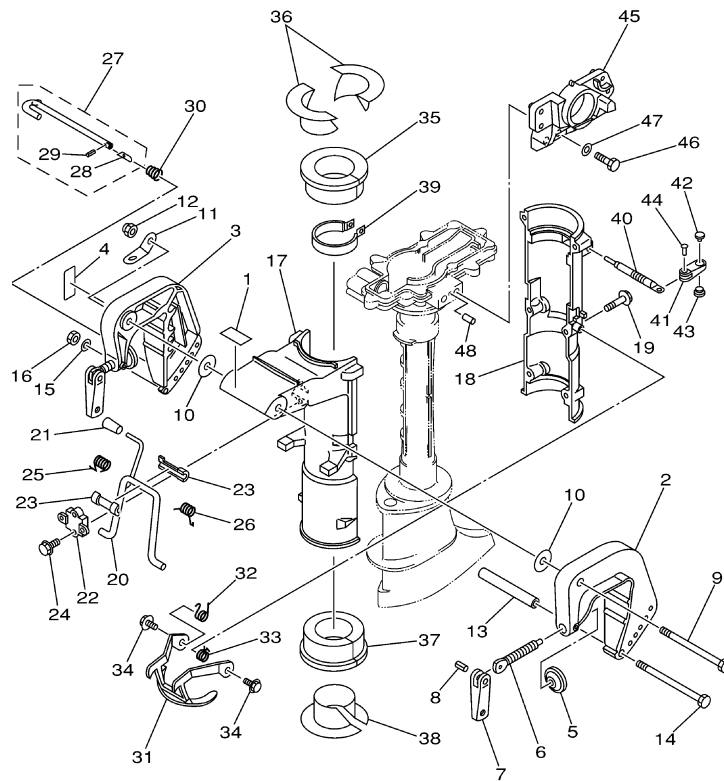

68D0010-1150

Part List

F4MSHB 2003 / BRACKET

REF - NO	PART NUMBER	PART NAME	QUANTITY	REMARKS
1	68D-F4591-00-00	EMBLEM, FUEL COCK	1	(F4)
2	6L8-G3111-01-4D	BRACKET, CLAMP 1	1	(F4)
3	6L8-G3112-00-4D	BRACKET, CLAMP 2	1	(F4)
4	6M0-G3318-00-00	COVER	1	(F4)
5	620-43114-00-00	PAD, TRANSOM CLAMP	2	(F4)
6	6E0-43116-01-00	SCREW, TRANSOM CLAMP	2	(F4)
7	6L8-G3118-01-00	HANDLE, TRANSOM CLAMP	2	(F4)
8	90243-04M01-00	PIN	2	(F4)
9	90101-08M07-00	BOLT	1	(F4)
10	90202-08M58-00	WASHER, PLATE	2	(F4)
11	68D-G3113-00-00	PLATE, CLAMP BRACKET	1	(F4)
12	90185-08057-00	.NUT, SELF-LOCKING	1	(F4)
13	90387-06M11-00	COLLAR	1	(F4)
14	90101-06335-00	BOLT	1	(F4)
15	92990-06600-00	WASHER, PLATE	1	(F4)
16	95380-06600-00	.NUT, HEXAGON	1	(F4)
17	68D-G3311-00-4D	BRACKET, SWIVEL 1	1	(F4)
18	68D-G3312-00-4D	BRACKET, SWIVEL 2	1	(F4)
19	95895-06035-00	BOLT, FLANGE	6	(F4)
20	6E0-43181-00-00	LEVER, TILT STOP	1	(F4)
21	6E0-43632-00-00	KNOB, TILT	1	(F4)
22	6E0-43313-00-4D	BRACKET, SWIVEL 3	1	(F4)
23	620-43189-00-00	BUSHING	2	(F4)
24	95895-06020-00	BOLT, FLANGE	2	(F4)
25	90508-16020-00	SPRING, TORSION	1	(F4)
26	90508-16021-00	SPRING, TORSION	1	(F4)
27	68D-G3160-00-00	TILT ROD ASSY	1	(F4)
28	6N0-G3165-00-00	..PLATE, TILT LOCK	1	(F4)
29	91690-30008-00	..PIN, SPRING	1	(F4)
30	90502-08M05-00	SPRING, CONICAL	1	(F4)
31	6E0-43614-00-5B	PLATE, TILT LOCK	1	(F4)
32	90508-14M10-00	SPRING, TORSION	1	(F4)
33	90508-14M11-00	SPRING, TORSION	1	(F4)
34	95895-06010-00	BOLT, FLANGE	2	(F4)
35	68D-G2537-00-00	BUSHING, PIVOT SHAFT	1	(F4)
36	68D-G2539-00-00	BUSHING, PIVOT SHAFT	2	(F4)
37	68D-G2538-00-00	BUSHING, PIVOT SHAFT	1	(F4)
38	68D-G2549-00-00	BUSHING, PIVOT SHAFT	1	(F4)
39	6E0-42528-03-00	PLATE, FRICTION	1	(F4)
40	6L5-42529-01-00	SCREW, FRICTION PIECE	1	(F4)
41	68D-G2561-01-00	KNOB, STEERING LOCK	1	(F4)
42	6L5-4196-00-00	INDICATOR 3	3	
43	6L5-44197-00-00	INDICATOR 4	4	
44	90266-04M05-00	RIVET	1	(F4)
45	68D-G2511-00-4D	BRACKET, STEERING	1	(F4)
46	97075-08030-00	BOLT	2	(F4)
47	92995-08600-00	.WASHER	2	(F4)
48	93604-12M07-00	PIN, DOWEL	1	(F4)

Part Notes

F4MSHB 2003 / BRACKET

PART NUMBER	NOTE TEXT
92990-06600-00 	OEM: This part number is among the Top 100 Most Popular Marine Maintenance Parts as of March 2014.

©2014 Yamaha Motor Corporation, U.S.A. All rights reserved.

F4MSHB 2003 / UPPER CASING

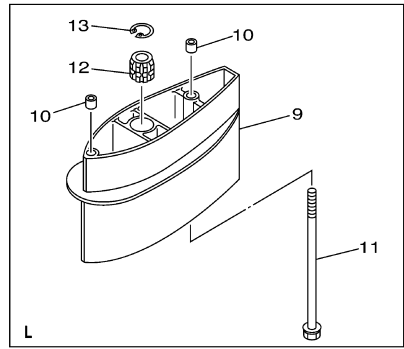
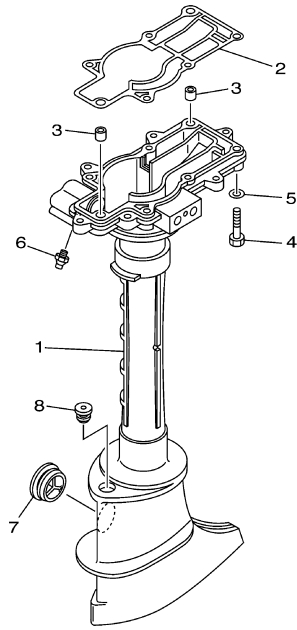

68D2010-2160

Part List

F4MSHB 2003 / UPPER CASING

REF - NO	PART NUMBER	PART NAME	QUANTITY	REMARKS
1	68D-G5111-01-4D	CASING, UPPER	1	
2	68D-G5113-A0-00	.GASKET, UPPER CASING	1	
3	90387-06806-00	COLLAR	2	
4	97095-06035-00	BOLT	7	
5	92995-06600-00	WASHER	7	
6	93700-06M03-00	NIPPLE, GREASE	1	
7	647-45151-01-00	COVER, UPPER CASING	1	
8	90480-10M13-00	GROMMET	1	
9	68D-G5211-00-4D	EXTENSION	1	L
10	90387-06806-00	COLLAR	2	L
11	90119-06M77-00	BOLT, WITH WASHER	2	L
12	6E0-45318-01-00	BUSHING, DRIVE SHAFT	1	L
13	93420-22M03-00	CIRCLIP	1	L

F4MSHB 2003 / LOWER CASING DRIVE 1

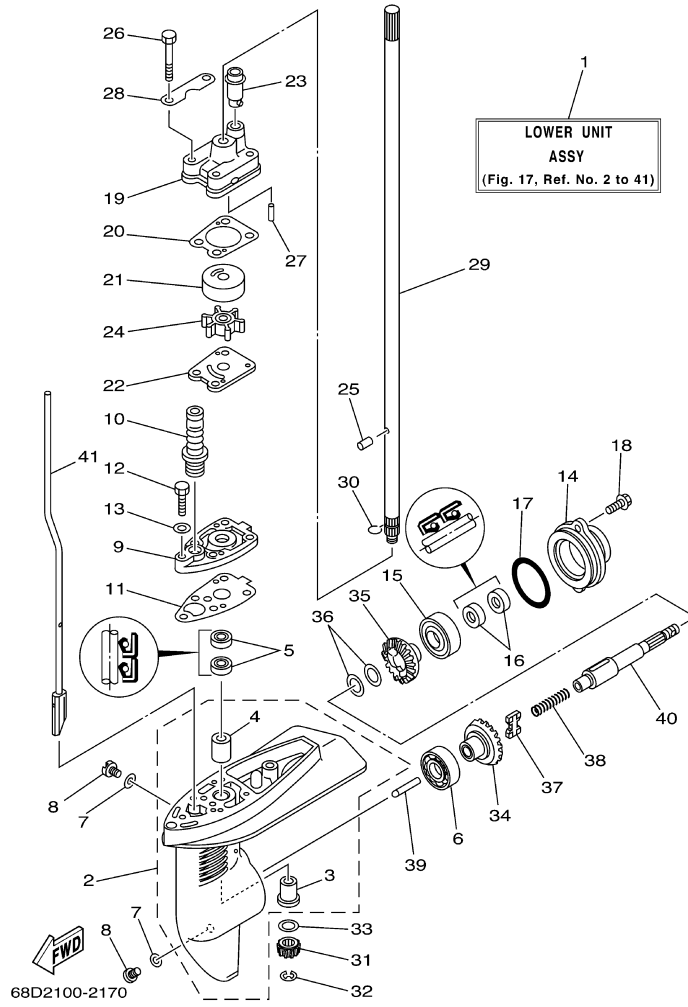

©2014 Yamaha Motor Corporation, U.S.A. All rights reserved.

Part List

F4MSHB 2003 / LOWER CASING DRIVE 1

REF - NO	PART NUMBER	PART NAME	QUANTITY	REMARKS
1	68D-G5300-11-4D	LOWER UNIT ASSY	1	L
1	68D-G5300-01-4D	LOWER UNIT ASSY	1	S
2	68D-G5311-00-4D	CASING, LOWER	1	
3	6E0-45317-09-00	.BUSHING, DRIVE SHAFT	1	
4	6E0-45316-09-00	.BUSHING, DRIVE SHAFT	1	
5	93101-10M14-00	.OIL SEAL	2	
6	93306-004YH-00	BEARING	1	
7	90430-08801-00	.GASKET	3	
8	90340-08002-00	PLUG, STRAIGHT SCREW	3	
9	68D-G5321-00-00	PLATE	1	
10	6L2-44147-00-00	BOOT, SHIFT ROD	1	
11	68D-G5315-A0-00	.PACKING, LOWER CASING	1	
12	97095-06025-00	BOLT	1	
13	92995-06600-00	WASHER	1	
14	68D-G5361-00-4D	CAP, LOWER CASING	1	
15	93306-004YH-00	BEARING	1	
16	93101-13M12-00	.OIL SEAL	2	
17	93210-48214-00	.O-RING	1	
18	95895-06016-00	BOLT, FLANGE	2	
19	68D-G4311-01-00	.HOUSING, WATER PUMP	1	
20	68D-G4315-A0-00	.GASKET, WATER PUMP	1	
21	68D-G4322-00-00	.INSERT, CARTRIDGE	1	
22	6E0-44323-00-00	OUTER PLATE, CARTRIDGE	1	
23	67D-44366-00-00	.DAMPER, WATER SEAL 2	1	
24	6E0-44352-00-00	IMPELLER	1	
25	93604-09066-00	PIN, DOWEL	1	
26	97095-06045-00	.BOLT	4	
27	93604-18080-00	.PIN, DOWEL	2	
28	68D-G4328-00-00	PLATE	2	
29	68D-G5511-10-00	SHAFT, DRIVE	1	L
29	68D-G5511-00-00	SHAFT, DRIVE	1	S
30	90467-08M01-00	CLIP	1	
31	6E0-45551-00-00	PINION (13T)	1	
32	99001-06600-00	CIRCLIP	1	
33	90201-11M49-00	WASHER, PLATE	1	
34	67D-45560-00-00	GEAR 1 (27T)	1	
35	67D-45570-00-00	GEAR 2 (27T)	1	
36	67D-45576-00-00	WASHER, THRUST 2	2	
37	67D-45631-01-00	CLUTCH, DOG	1	
38	90501-10064-00	SPRING, COMPRESSION	1	
39	67D-45635-00-00	PLUNGER, SHIFT	1	
40	68D-G5611-10-00	SHAFT, PROPELLER	1	
41	68D-G4150-10-00	SHIFT CAM ASSY	1	L
41	68D-G4150-00-00	SHIFT CAM ASSY	1	S

F4MSHB 2003 / LOWER CASING DRIVE 2

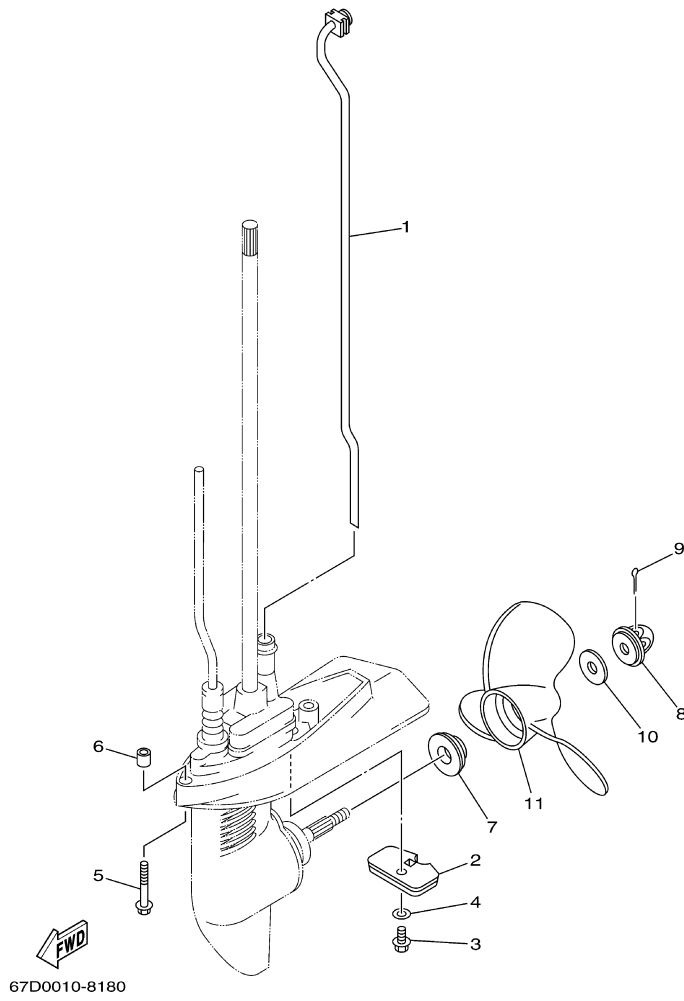

©2014 Yamaha Motor Corporation, U.S.A. All rights reserved.

Part List

F4MSHB 2003 / LOWER CASING DRIVE 2

REF - NO	PART NUMBER	PART NAME	QUANTITY	REMARKS
1	68D-G4360-10-00	WATER TUBE ASSY	1	L
1	68D-G4360-00-00	WATER TUBE ASSY	1	S
2	68D-G5251-00-00	ANODE	1	
3	95895-06012-00	BOLT, FLANGE	1	
4	92990-06300-00	WASHER, INTERNAL TOOTH	1	
5	90119-06M40-00	BOLT, WITH WASHER	2	S
6	90387-06806-00	COLLAR	2	
7	68D-G5987-00-00	SPACER 1	1	
8	6L5-45616-00-00	NUT, PROPELLER	1	
9	91490-25030-00	PIN. COTTER	1	
10	90201-08M54-00	WASHER, PLATE	1	
11	6E0-45943-01-EL	PROPELLER (3X7-1/2"X7"- BA)	1	UR
11	6E0-45949-00-EL	PROPELLER (3X7-1/4"X6- 1/2"-BA)	1	UR
11	6E0-45941-01-EL	PROPELLER (3X7-1/2"X8"- BA)	1	UR

F4MSHB 2003 / REPAIR KIT 1

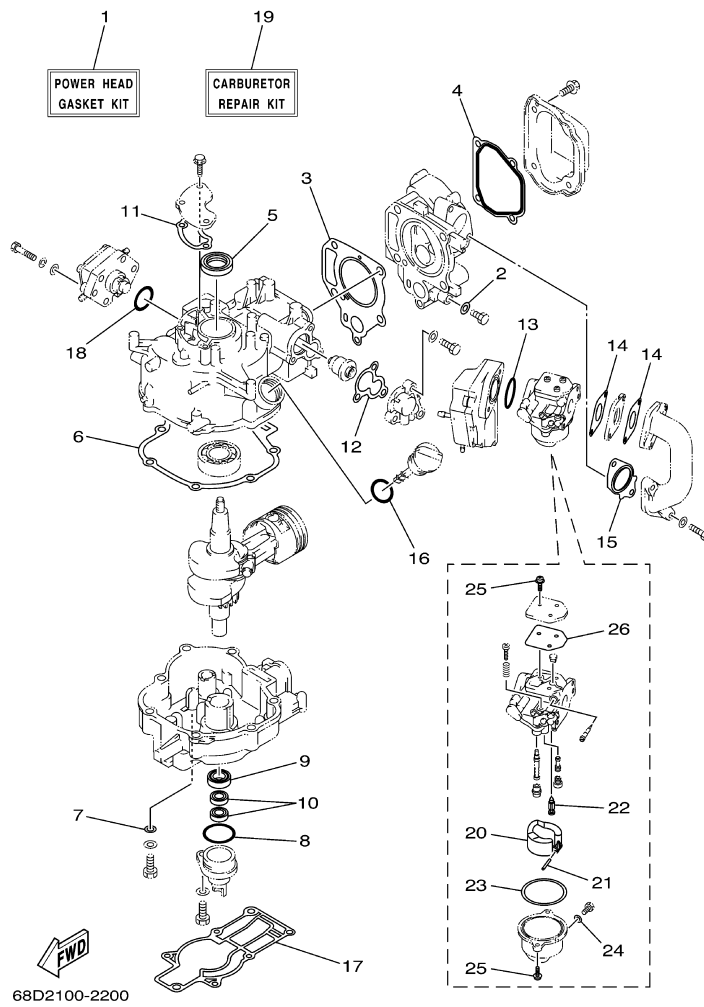

©2014 Yamaha Motor Corporation, U.S.A. All rights reserved.

Part List

F4MSHB 2003 / REPAIR KIT 1

REF - NO	PART NUMBER	PART NAME	QUANTITY	REMARKS
1	68D-WE001-00-00	POWER HEAD GASKET KIT	1	
2	90430-08800-00	.GASKET	1	
3	67D-11181-A0-00	.GASKET, CYLINDER HEAD 1	1	
4	68D-E1193-A0-00	.GASKET, HEAD COVER 1	1	
5	93102-25090-00	.OIL SEAL	1	
6	68D-11351-A0-00	.GASKET, CYLINDER	1	
7	90201-08818-00	.WASHER, PLATE	1	
8	93210-35537-00	.O-RING	1	
9	93102-20108-00	.OIL SEAL	1	
10	93102-10004-00	.OIL SEAL	2	
11	68D-E1169-A0-00	.GASKET, BREATHER COVER	1	
12	68D-E2414-A0-00	.GASKET, COVER	1	
13	93210-31MJ5-00	.O-RING	1	
14	68D-E3646-A0-00	.GASKET, MANIFOLD 2	2	
15	68D-E3645-A0-00	.GASKET, MANIFOLD 1	1	
16	93210-24M79-00	.O-RING	1	
17	68D-G5113-A0-00	.GASKET, UPPER CASING	1	
18	93210-27ME3-00	.O-RING	1	
19	67D-W0093-01-00	CARBURETOR REPAIR KIT	1	
20	68T-14385-00-00	.FLOAT	1	
21	67D-14386-00-00	.PIN, FLOAT	1	
22	67D-14546-00-00	.VALVE, NEEDLE	1	
23	67D-14984-00-00	.GASKET, FLOAT CHAMBER	1	
24	6J8-14959-00-00	.GASKET	1	
25	97980-04112-00	.SCREW, WITH WASHER	2	
26	67D-14536-00-00	.GASKET	1	

F4MSHB 2003 / REPAIR KIT 2

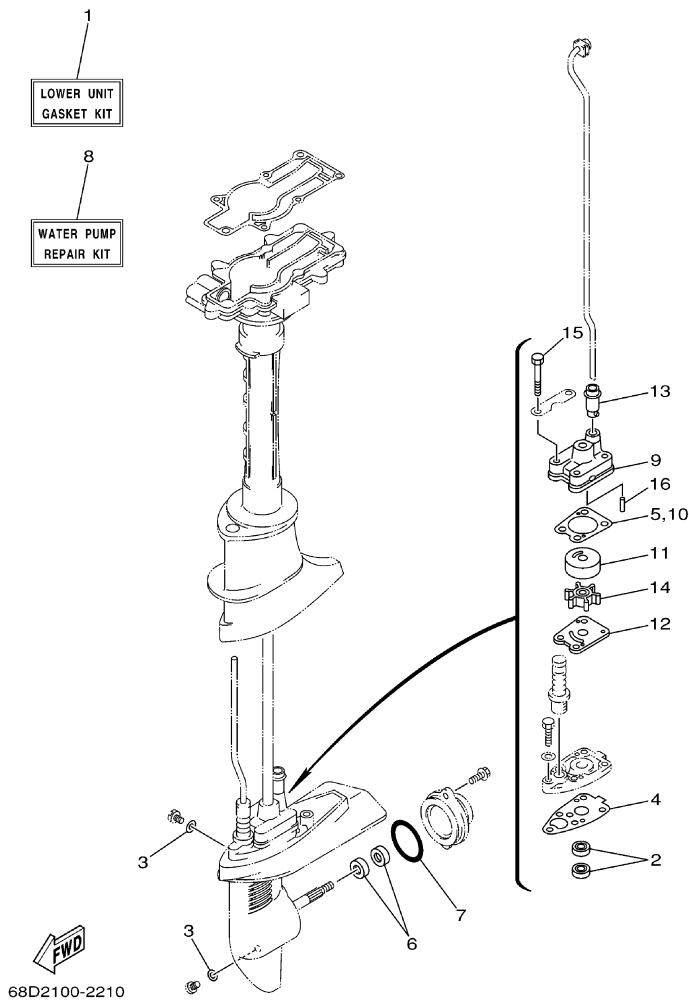

©2014 Yamaha Motor Corporation, U.S.A. All rights reserved.

Part List

F4MSHB 2003 / REPAIR KIT 2

REF - NO	PART NUMBER	PART NAME	QUANTITY	REMARKS
1	6E0-W0001-C1-00	LOWER UNIT GASKET KIT	1	
2	93101-10M14-00	.OIL SEAL	2	
3	90430-08801-00	.GASKET	3	
4	68D-G5315-A0-00	.PACKING, LOWER CASING	1	
5	68D-G4315-A0-00	.GASKET, WATER PUMP	1	
6	93101-13M12-00	.OIL SEAL	2	
7	93210-48214-00	.O-RING	1	
8	68D-WG078-00-00	WATER PUMP REPAIR KIT	1	
9	68D-G4311-01-00	.HOUSING, WATER PUMP	1	
10	68D-G4315-A0-00	.GASKET, WATER PUMP	1	
11	68D-G4322-00-00	.INSERT, CARTRIDGE	1	
12	6E0-44323-00-00	.OUTER PLATE, CARTRIDGE	1	
13	67D-44366-00-00	.DAMPER, WATER SEAL 2	1	
14	6E0-44352-00-00	.IMPELLER	1	
15	97095-06045-00	.BOLT	4	
16	93604-18080-00	.PIN, DOWEL	2	

F4MSHB 2003 / MODELS IN THIS CATALOG

F4MSHB (68D3)

Engine Serial No. (F4MSHB): 68DS-1000001 and following

F4MLHB (68D3)

Engine Serial No. (F4MLHB): 68DL-1000130 and following

**ALL THESE MODELS USE THIS SAME PARTS CATALOG.
BE SURE TO ORDER ONLY THOSE PARTS APPLICABLE
TO THE DESIRED MODEL.**

©2014 Yamaha Motor Corporation, U.S.A. All rights reserved.

©2014 Yamaha Motor Corporation, U.S.A. All rights reserved.