

F2.5MSH 0406 / TOP COWLING

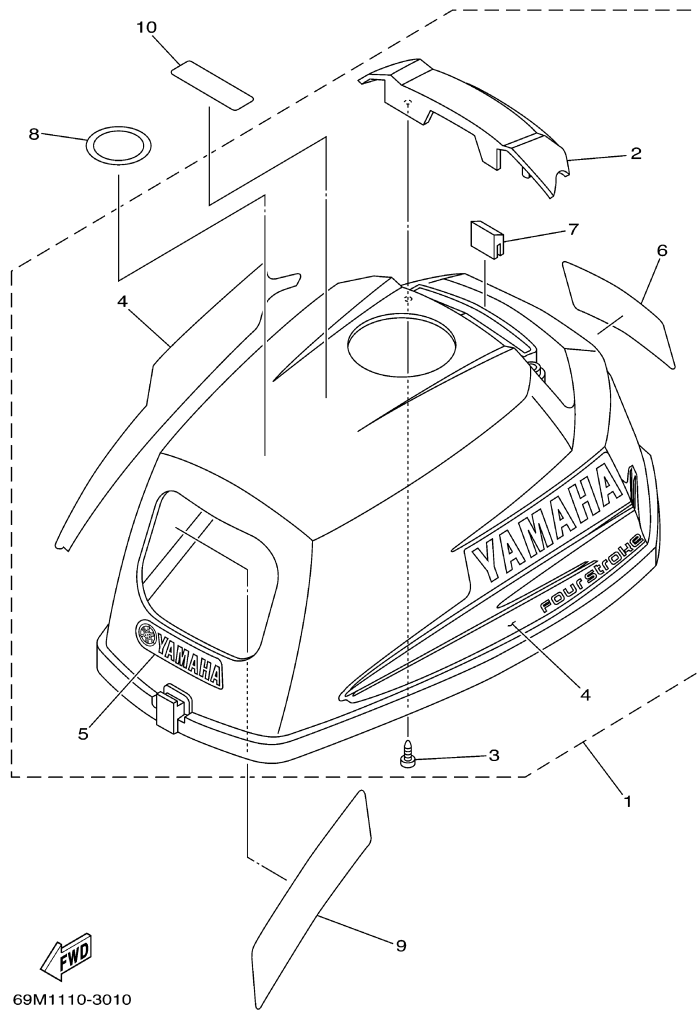

Part List

F2.5MSH 0406 / TOP COWLING

REF - NO	PART NUMBER	PART NAME	QUANTITY	REMARKS
1	69M-G2610-10-4D	TOP COWLING ASSY	1	
2	69M-G2613-00-00	.MOLDING, AIR DUCT	1	
3	97780-40012-00	.SCREW, TAPPING	2	
4	69M-WG070-00-00	.GRAPHIC SET	1	
5	69M-G2677-00-00	.GRAPHIC, FRONT	1	
6	69M-G2678-10-00	.GRAPHIC, REAR	1	
7	69M-42662-00-00	.DAMPER	1	
8	60R-E3434-00-00	LABEL, CAUTION	1	
9	69M-E4427-40-00	LABEL, INSTRUCTION	1	
10	69M-F415A-40-00	LABEL, CAUTION	1	

F2.5MSH 0406 / CYLINDER CRANKCASE 1

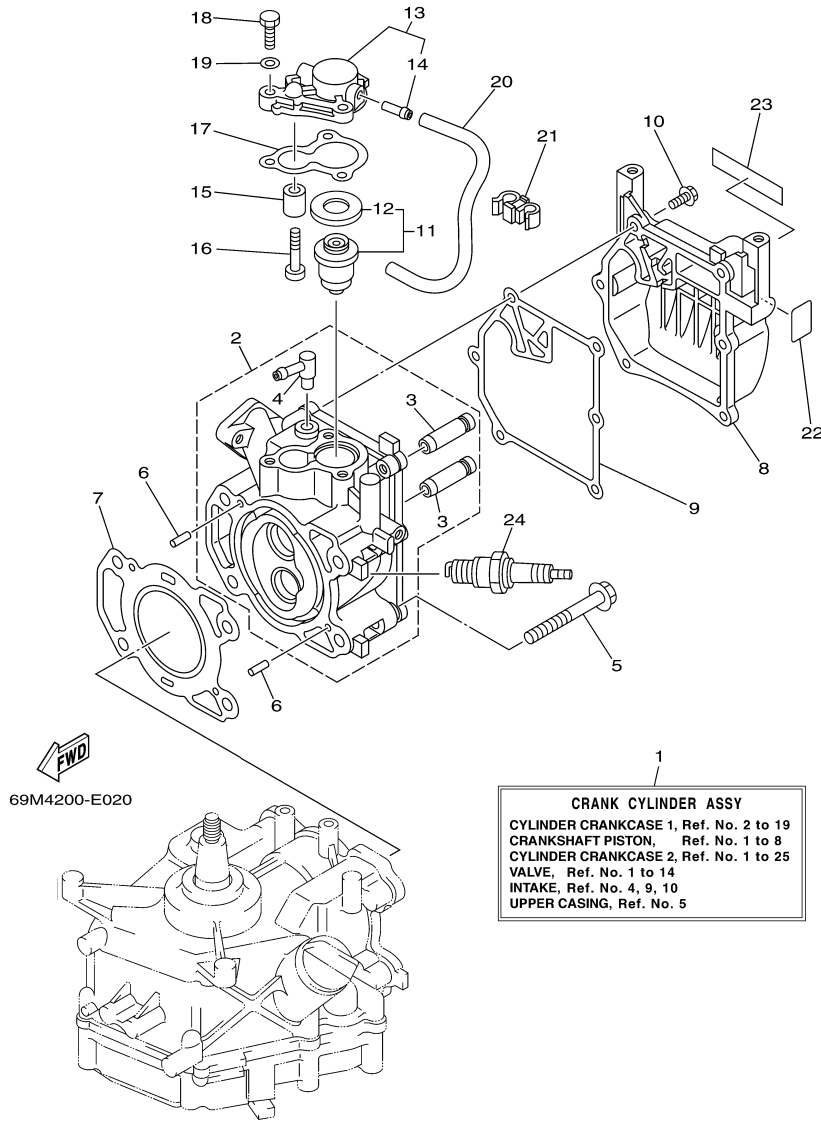

Part List

F2.5MSH 0406 / CYLINDER CRANKCASE 1

REF - NO	PART NUMBER	PART NAME	QUANTITY	REMARKS
1	69M-WE090-01-1S	CRANK CYLINDER ASSY	1	
2	69M-E1111-00-1S	HEAD, CYLINDER 1	1	
3	67D-11133-10-00	.GUIDE, VALVE 1	2	
4	676-11372-00-00	.NIPPLE, HOSE	1	
5	90105-08M36-00	BOLT, FLANGE	4	
6	93604-12M07-00	PIN, DOWEL	2	
7	69M-11181-00-00	.GASKET, CYLINDER HEAD 1	1	
8	69M-E1191-00-1S	COVER, CYLINDER HEAD 1	1	
9	69M-11193-A0-00	.GASKET, HEAD COVER 1	1	
10	90105-06039-00	BOLT, FLANGE	6	
11	69M-12411-01-00	THERMOSTAT	1	
12	688-12412-00-00	.SEAL, THERMOSTAT	1	
13	69M-E2413-00-1S	COVER, THERMOSTAT	1	
14	650-24378-00-00	.PIPE, JOINT 4	1	
15	68D-E1325-00-00	ANODE	1	
16	97880-05025-00	SCREW, PAN HEAD	1	
17	68D-E2414-A0-00	.GASKET, COVER	1	
18	97095-06020-00	BOLT	3	
19	92995-06600-00	WASHER	3	
20	90445-09808-00	HOSE (L240)	1	
21	90464-09013-00	CLAMP	1	
22	67D-42791-10-00	MARK 1	1	
23	68D-E2138-40-00	MARK, CAUTION	1	
24	NGK-BR6HS-10-00	PLUG, SPARK (NGK BR6HS-10)	1	

F2.5MSH 0406 / CRANKSHAFT PISTON

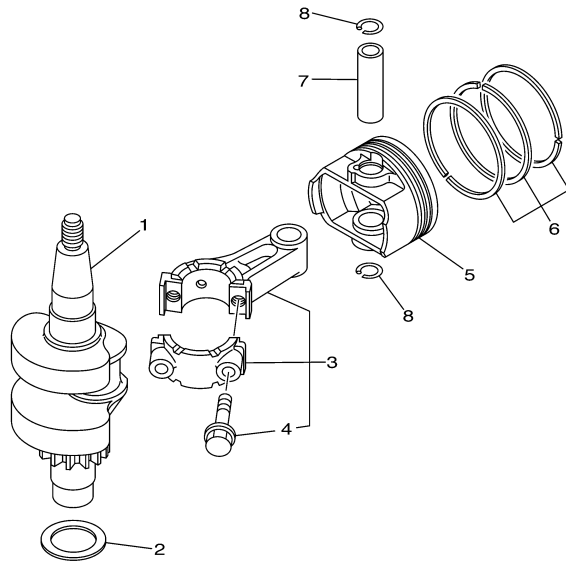

69M1010-3030

Part List

F2.5MSH 0406 / CRANKSHAFT PISTON

REF - NO	PART NUMBER	PART NAME	QUANTITY	REMARKS
1	69M-11400-00-00	CRANKSHAFT ASSY	1	
2	90201-23008-00	WASHER, PLATE	1	
3	69M-11650-00-00	CONNECTING ROD ASSY	1	
4	7FK-11654-00-00	.BOLT, CONNECTING ROD	2	
5	69M-E1631-01-96	PISTON (STD)	1	
5	69M-E1635-01-00	PISTON (0.25MM O/S)	1	AP
5	69M-E1636-01-00	PISTON (0.50MM O/S)	1	AP
6	69M-E1603-01-00	PISTON RING SET (STD)	1	
6	69M-E1604-01-00	PISTON RING SET (0.25MM O/S)	1	AP
6	69M-E1605-01-00	PISTON RING SET (0.50MM O/S)	1	AP
7	69M-E1633-00-00	PIN, PISTON	1	
8	93450-13130-00	CIRCLIP	2	

F2.5MSH 0406 / CYLINDER CRANKCASE 2

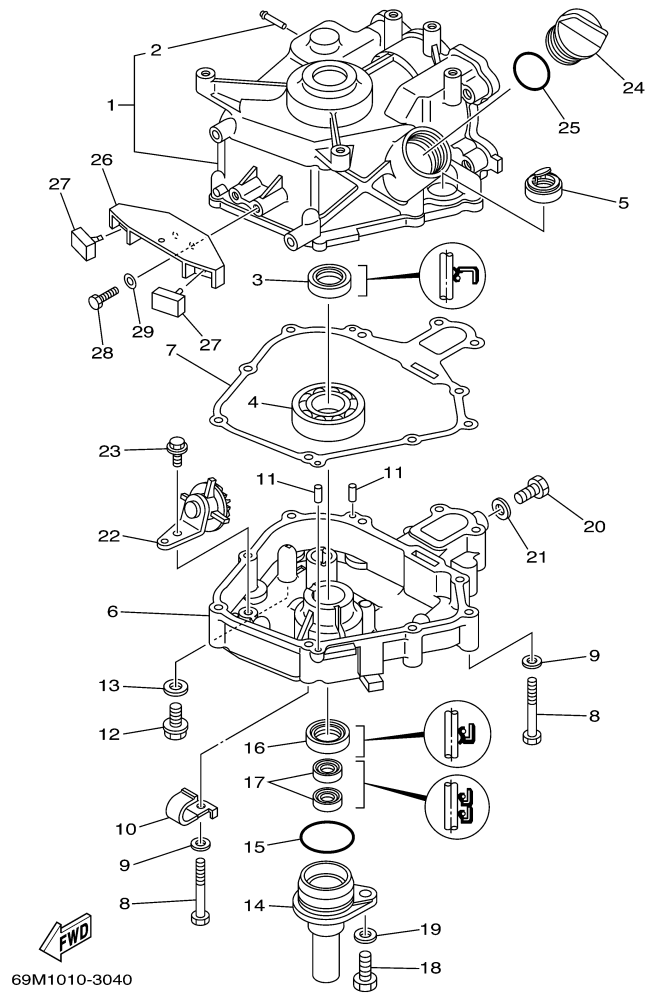

Part List

F2.5MSH 0406 / CYLINDER CRANKCASE 2

REF - NO	PART NUMBER	PART NAME	QUANTITY	REMARKS
1	69M-E1311-00-1S	CYLINDER 1	1	
2	6H1-14485-00-00	.PIPE, JOINT	1	
3	93102-20108-00	OIL SEAL	1	
4	93306-272Y2-00	BEARING	1	
5	69M-15361-00-00	GAUGE, LEVEL	1	
6	69M-E5111-00-1S	CRANKCASE 1	1	
7	69M-11351-A0-00	.GASKET, CYLINDER	1	
8	97013-06045-00	BOLT	10	
9	92903-06600-00	WASHER, PLATE	10	
10	90465-08M99-00	CLAMP	1	
11	93604-12M07-00	PIN, DOWEL	2	
12	90105-08M76-00	BOLT, FLANGE	1	
13	90201-08818-00	WASHER, PLATE	1	
14	69M-E5396-00-5B	HOUSING, OIL SEAL	1	
15	93210-35537-00	O-RING	1	
16	93102-20108-00	OIL SEAL	1	
17	93102-09004-00	.OIL SEAL	2	
18	97095-08020-00	BOLT	1	
19	92995-08600-00	WASHER	1	
20	97095-08014-00	BOLT	1	
21	90430-08800-00	.GASKET	1	
22	69M-E3102-00-00	GEAR UNIT ASSY	1	
23	95817-06012-00	BOLT, FLANGE	1	
24	69M-E5363-00-00	PLUG, OIL	1	
25	93210-24M79-00	.O-RING	1	
26	69M-G2743-00-00	BRACKET	1	
27	6G8-44532-00-00	STOPPER, UPPER MOUNT	2	
28	97095-06020-00	BOLT	2	
29	92995-06600-00	WASHER	2	

F2.5MSH 0406 / VALVE

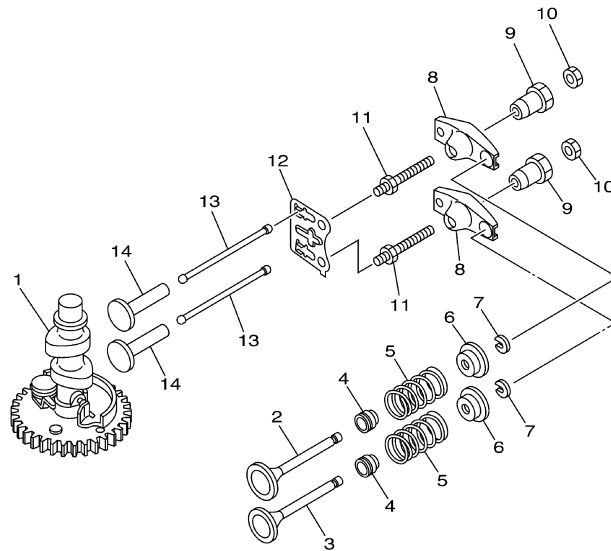

69M1010-3050

©2014 Yamaha Motor Corporation, U.S.A. All rights reserved.

Part List

F2.5MSH 0406 / VALVE

REF - NO	PART NUMBER	PART NAME	QUANTITY	REMARKS
1	69M-12170-01-00	CAMSHAFT ASSY 1	1	
2	67D-12111-00-00	VALVE, INTAKE	1	
3	67D-12121-00-00	VALVE, EXHAUST	1	
4	51Y-12119-00-00	SEAL, VALVE STEM	2	
5	68D-E2113-00-00	SPRING, VALVE INNER	2	
6	7NJ-12117-00-00	RETAINER, VALVE SPRING	2	
7	7NJ-12118-00-00	LOCK, VALVE SPRING RETAINER	2	
8	67D-12151-00-00	ARM, VALVE ROCKER	2	
9	7FK-12165-00-00	PIVOT, ROCKER ARM	2	
10	7FK-12158-00-00	NUT, LOCK	2	
11	67D-12157-00-00	BOLT	2	
12	69M-E2155-00-00	GUIDE, PUSH ROD	1	
13	69M-12154-00-00	ROD, VALVE PUSH	2	
14	JA9-12153-00-00	LIFTER, VALVE	2	

F2.5MSH 0406 / INTAKE

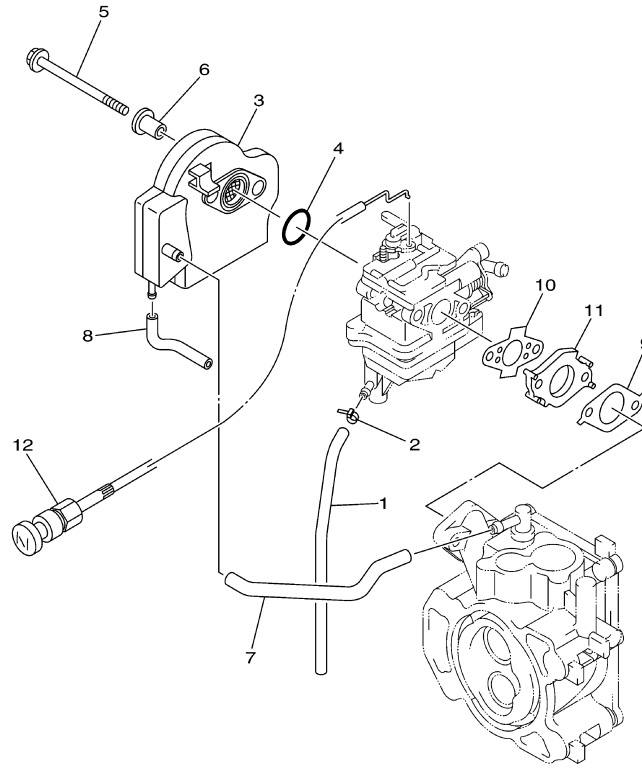

69M2100-C060

Part List

F2.5MSH 0406 / INTAKE

REF - NO	PART NUMBER	PART NAME	QUANTITY	REMARKS
1	69M-E4148-00-00	PIPE	1	
2	90465-11M10-00	CLAMP	1	
3	69M-14440-01-00	SILENCER ASSY, INTAKE	1	
4	93210-20M65-00	.O-RING	1	
5	97595-06575-00	BOLT, WITH WASHER	2	
6	90387-06076-00	COLLAR	2	
7	69M-E2483-00-00	PIPE 3	1	
8	90445-07805-00	HOSE (L70)	1	
9	69M-E3645-A0-00	.GASKET, MANIFOLD 1	1	
10	69M-E3646-A0-00	.GASKET, MANIFOLD 2	1	
11	69M-E3647-00-00	GASKET, MANIFOLD 3	1	
12	69M-F6330-01-00	STARTER CABLE ASSY	1	

F2.5MSH 0406 / CARBURETOR

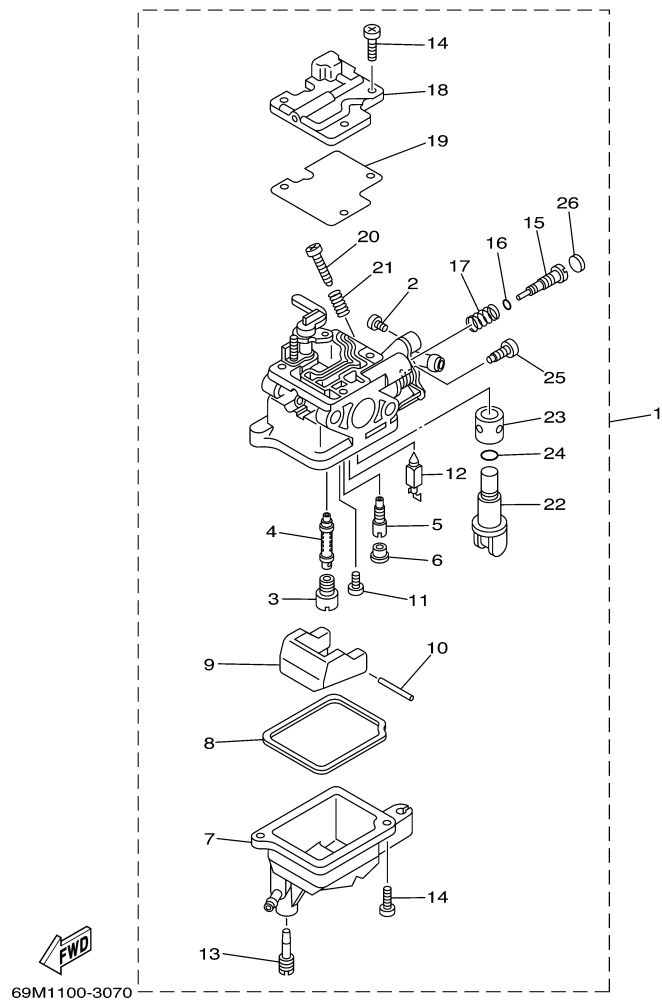

Part List

F2.5MSH 0406 / CARBURETOR

REF - NO	PART NUMBER	PART NAME	QUANTITY	REMARKS
1	69M-14301-10-00	CARBURETOR ASSY 1	1	
2	97890-04007-00	.SCREW, PAN HEAD	2	
3	69M-14343-31-00	.JET, MAIN (# 62)	1	
4	69M-14341-00-00	.NOZZLE, MAIN	1	
5	69M-14342-68-00	.JET, PILOT (#37)	1	
6	69M-14966-00-00	.BUSH	1	
7	69M-14381-00-00	.BODY, FLOAT CHAMBER	1	
8	69M-14984-00-00	.GASKET, FLOAT CHAMBER	1	
9	69M-14385-00-00	.FLOAT	1	
10	6A1-14386-00-00	.PIN, FLOAT	1	
11	98580-03005-00	.SCREW, PAN HEAD	1	
12	62Y-14392-00-00	.VALVE, NEEDLE	1	
13	69M-14991-00-00	.SCREW	1	
14	98580-04010-00	.SCREW, PAN HEAD	5	
15	69M-14323-00-00	.SCREW, AIR ADJUSTING	1	
16	2T4-14397-00-00	.O-RING	1	
17	62Y-14334-00-00	.SPRING, AIR ADJUSTING	1	
18	69M-14527-00-00	.PLATE	1	
19	69M-14536-00-00	.GASKET	1	
20	69W-14321-00-00	.SCREW, THROTTLE	1	
21	62Y-14212-00-00	.SPRING, PILOT ADJUSTING	1	
22	69M-24524-00-00	.LEVER, COCK	1	
23	69M-24523-00-00	.VALVE	1	
24	69M-24533-00-00	.O-RING	1	
25	69M-24535-00-00	.SCREW, LEVER FITTING	1	
26	62Y-1432A-01-00	.PLUG	1	

F2.5MSH 0406 / FUEL

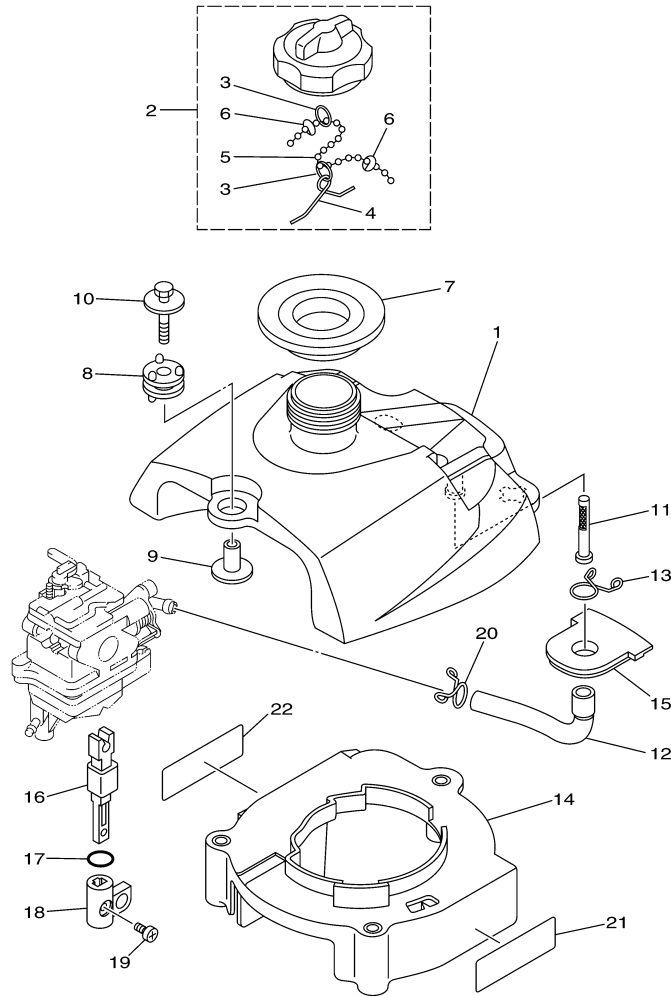



69M2110-C080

Part List

F2.5MSH 0406 / FUEL

REF - NO	PART NUMBER	PART NAME	QUANTITY	REMARKS
1	69M-F4111-00-00	TANK, FUEL	1	
2	67D-24610-02-00	CAP ASSY	1	
3	90501-10260-00	.SPRING, COMPRESSION	2	
4	624-24634-00-00	.HOOK, CHAIN BALL	1	
5	69M-24633-00-00	.CHAIN, BALL	1	
6	6H1-21757-00-00	.WASHER, SPECIAL 1	2	
7	69M-24641-00-00	GASKET, CAP 1	1	
8	69M-F4375-00-00	GROMMET	3	
9	90387-06053-00	COLLAR	3	
10	90119-06098-00	BOLT, WITH WASHER	3	
11	6L5-24251-00-00	STRAINER 1	1	
12	69M-F4311-00-00	PIPE, FUEL 1	1	
13	90467-13M13-00	CLIP	1	
14	69M-F4191-00-00	BRACKET, FUEL TANK 1	1	
15	69M-F4181-00-00	DAMPER, LOCATING 1	1	
16	69M-24554-00-00	SHAFT, COCK	1	
17	93210-13M43-00	.O-RING	1	
18	69M-24575-00-00	LEVER, FUEL CHANGE	1	
19	90159-05M12-00	SCREW, WITH WASHER	1	
20	90467-11M08-00	CLIP	1	
21	69M-E3437-40-00	MARK, CAUTION	1	
22	60R-H3625-40-00	MARK 5	1	

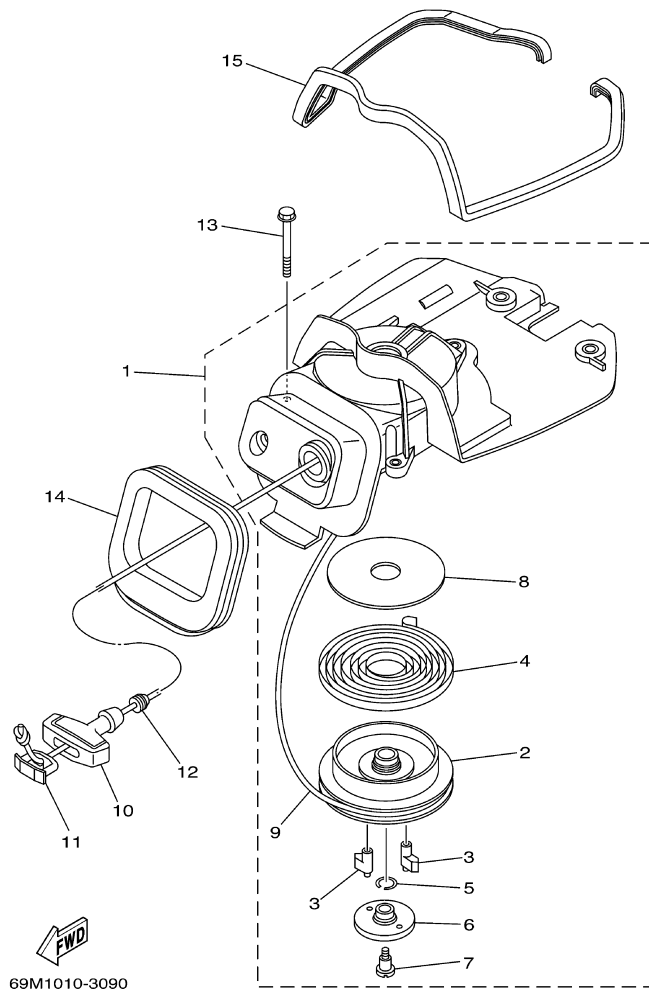
F2.5MSH 0406 / STARTER



Part List

F2.5MSH 0406 / STARTER

REF - NO	PART NUMBER	PART NAME	QUANTITY	REMARKS
1	69M-15710-00-00	STARTER ASSY	1	
2	69M-15714-00-00	.DRUM, SHEAVE	1	
3	69M-15741-00-00	.PAWL, DRIVE	2	
4	67D-15713-00-00	.SPRING, STARTER	1	
5	67D-15705-00-00	.SPRING, DRIVE PAWL	1	
6	69M-15735-00-00	.GUIDE, CAM	1	
7	69M-15793-00-00	.SCREW	1	
8	69M-15739-00-00	.WASHER, THRUST	1	
9	69M-15751-00-00	.WIRE, STARTER (L:1500MM)	1	
10	6G1-15755-00-00	.HANDLE, STARTER	1	
11	6G1-15779-00-00	.COVER	1	
12	69M-E5789-00-00	DAMPER	1	
13	97595-06560-00	BOLT, WITH WASHER	3	
14	69M-15762-00-00	SEAL, RUBBER 2	1	
15	69M-24182-00-00	DAMPER, LOCATING 2	1	

F2.5MSH 0406 / GENERATOR

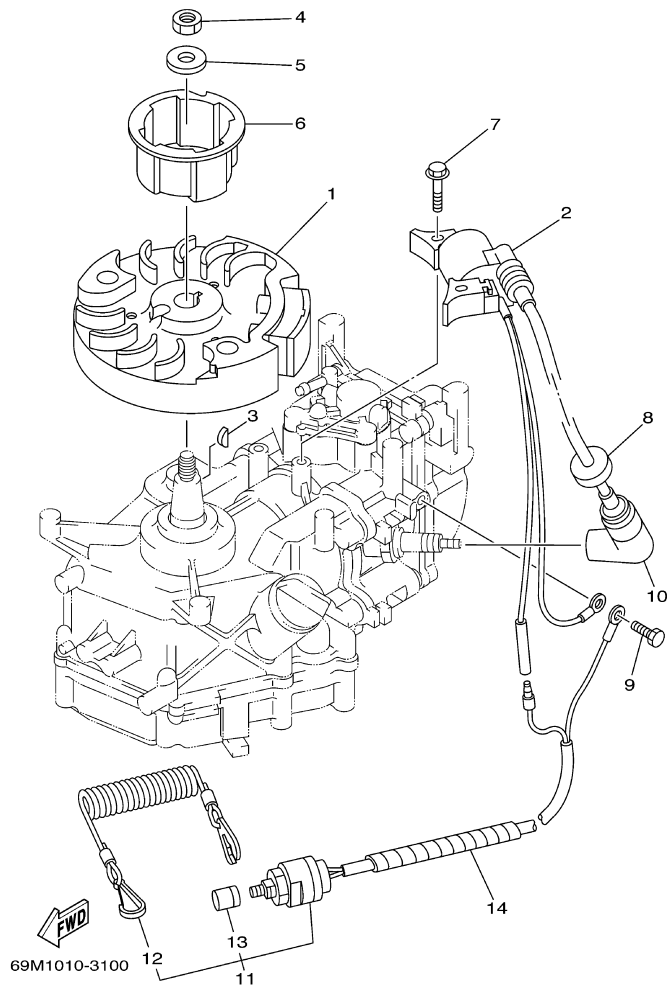

©2014 Yamaha Motor Corporation, U.S.A. All rights reserved.

Part List

F2.5MSH 0406 / GENERATOR

REF - NO	PART NUMBER	PART NAME	QUANTITY	REMARKS
1	69M-85650-00-00	ROTOR ASSY	1	
2	69M-85640-00-00	T.C.I. UNIT ASSY	1	
3	90280-04M06-00	KEY, WOODRUFF	1	
4	90170-10M33-00	NUT	1	
5	90201-105A2-00	WASHER, PLATE	1	
6	69M-15723-00-00	PULLEY, STARTER	1	
7	90105-06M24-00	BOLT, FLANGE	2	
8	90480-25161-00	GROMMET	1	
9	97095-06012-00	BOLT	1	
10	6E3-82370-21-00	PLUG CAP ASSY	1	
11	65W-82575-01-00	ENGINE STOP SWITCH ASSY	1	
12	682-82556-00-00	.LANYARD, STOP SWITCH	1	
13	689-8257Y-00-00	.CAP	1	
14	90446-06M90-00	HOSE (L120)	1	

Part Notes

F2.5MSH 0406 / GENERATOR

PART NUMBER	NOTE TEXT
682-82556-00-00 	OEM: This part number is among the Top 100 Most Popular Marine Maintenance Parts as of March 2014.

©2014 Yamaha Motor Corporation, U.S.A. All rights reserved.

F2.5MSH 0406 / BOTTOM COWLING

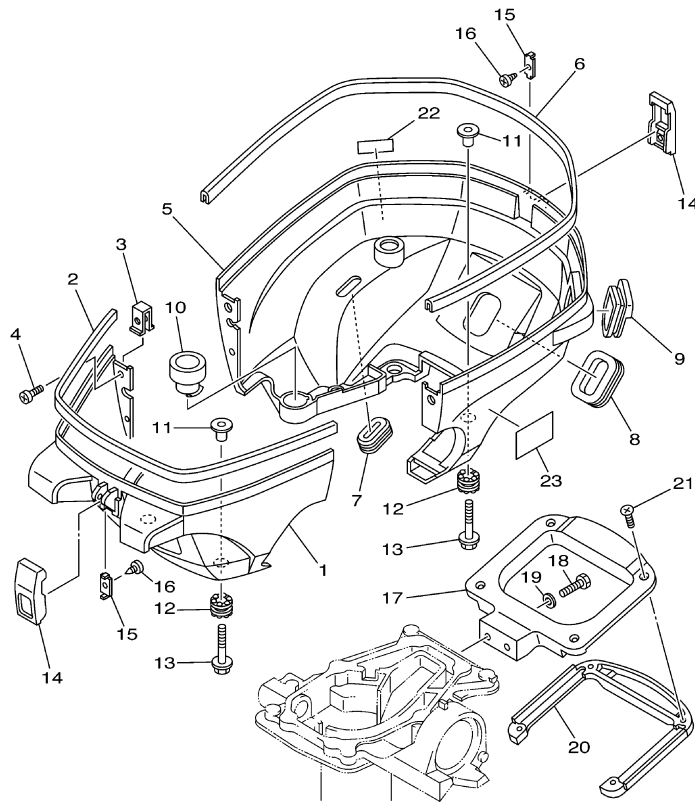

69M1010-3110

Part List

F2.5MSH 0406 / BOTTOM COWLING

REF - NO	PART NUMBER	PART NAME	QUANTITY	REMARKS
1	69M-G2711-00-4D	COWLING, BOTTOM 1	1	
2	69M-42628-00-00	SEAL	1	
3	6L5-42774-00-00	STAY, APRON 1	2	
4	90157-05013-00	SCREW, PAN HEAD	2	
5	69M-G2712-00-00	COWLING, BOTTOM 2	1	
6	69M-42629-00-00	SEAL	1	
7	69M-G2727-00-00	GROMMET	1	
8	69M-G2724-00-00	GROMMET	1	
9	69M-G2725-00-00	GROMMET	1	
10	69M-E5316-00-00	DAMPER 1	1	
11	69M-42758-00-00	COLLAR	4	
12	69M-G2768-00-00	DAMPER	4	
13	90119-06M17-00	BOLT, WITH WASHER	4	
14	6L5-42647-00-00	HOLDER, CLAMP BAND	2	
15	6L5-42823-00-00	PLATE, STOP	2	
16	90167-03M02-00	SCREW, TAPPING	2	
17	69M-G2731-00-4D	CARRYING HANDLE	1	
18	97095-06020-00	BOLT	2	
19	92995-06600-00	WASHER	2	
20	69M-G2735-00-00	PROTECTOR	1	
21	90161-04003-00	SCREW, TAPPING	4	
22	69M-F4591-00-00	EMBLEM, FUEL COCK	1	
23	69M-E3444-40-00	MARK	1	

F2.5MSH 0406 / STEERING

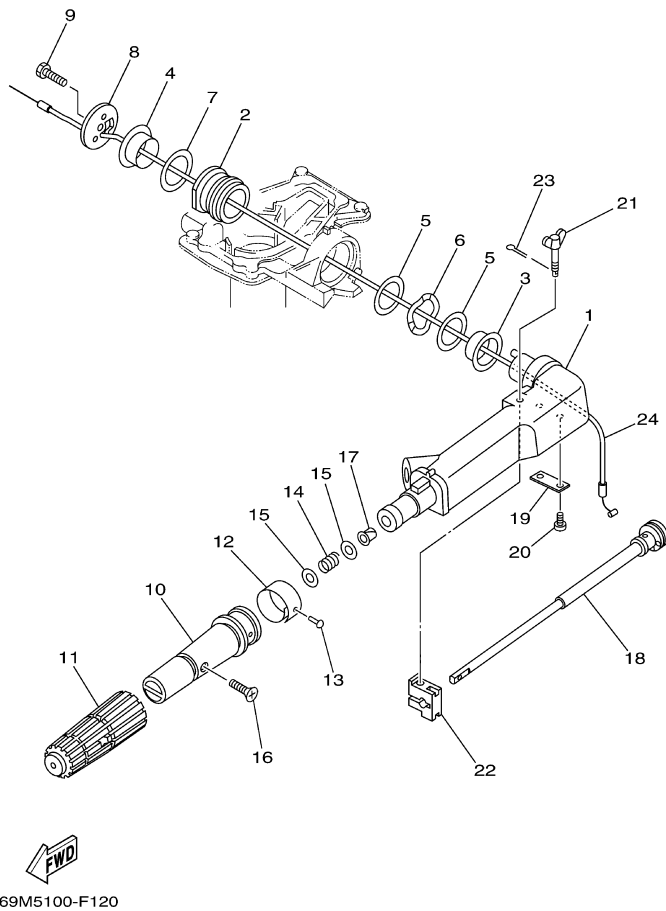

©2014 Yamaha Motor Corporation, U.S.A. All rights reserved.

Part List

F2.5MSH 0406 / STEERING

REF - NO	PART NUMBER	PART NAME	QUANTITY	REMARKS
1	69M-G2111-00-4D	HANDLE, STEERING	1	
2	67D-42129-00-00	BUSHING, RUBBER	1	
3	68D-G2171-00-00	BUSHING	1	
4	68D-G2172-00-00	BUSHING 2	1	
5	68D-G2181-00-00	WASHER	2	
6	69M-G2188-00-00	WASHER, WAVE	1	
7	68D-G2182-00-00	WASHER 2	1	
8	68D-G2131-01-00	COVER, HANDLE STEERING	1	
9	97075-08025-00	BOLT	1	
10	69M-G2119-10-00	GRIP, STEERING HANDLE	1	
11	6N0-G2177-00-00	RUBBER, HANDLE	1	
12	69M-G2137-00-00	INDICATOR, THROTTLE	1	
13	90269-02M09-00	RIVET	1	
14	90501-23800-00	SPRING, COMPRESSION	1	
15	90201-10M02-00	WASHER, PLATE	2	
16	90149-05M13-00	SCREW	1	
17	90386-08032-00	BUSH	1	
18	6G1-42138-01-00	LEVER, THROTTLE	1	
19	68D-G2159-00-00	STAY	1	
20	97885-05012-00	SCREW, PAN HEAD	2	
21	6G1-42125-01-00	BOLT, FRICTION ADJUSTING	1	
22	6G1-42126-00-00	FRICTION, STEERING HANDLE GRIP	1	
23	91490-16010-00	PIN. COTTER	1	
24	69M-F6301-00-00	THROTTLE CABLE ASSY	1	

F2.5MSH 0406 / CONTROL

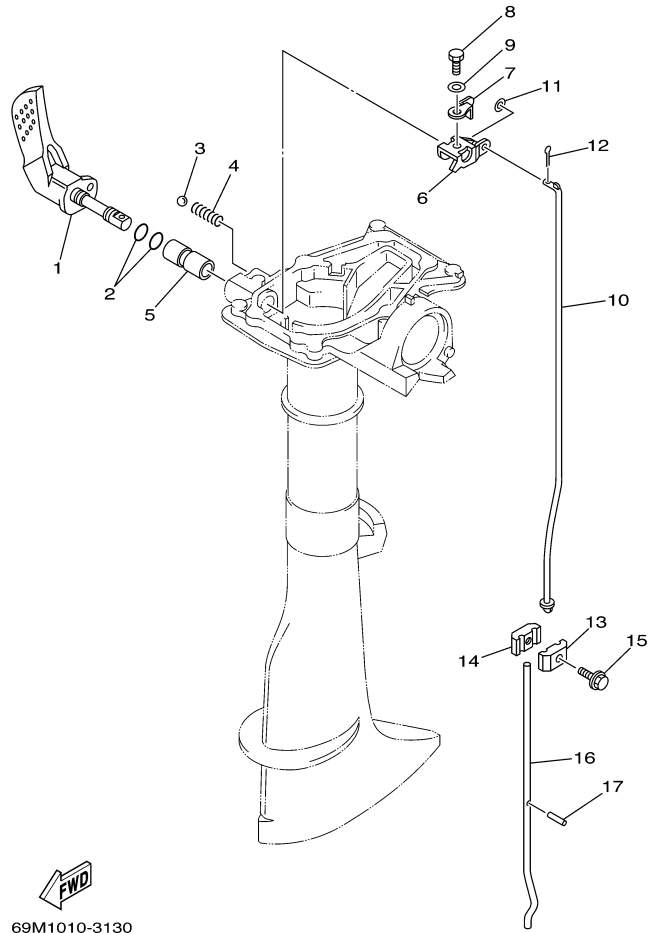

69M1010-3130

©2014 Yamaha Motor Corporation, U.S.A. All rights reserved.

Part List

F2.5MSH 0406 / CONTROL

REF - NO	PART NUMBER	PART NAME	QUANTITY	REMARKS
1	69M-G4111-00-00	HANDLE, GEAR SHIFT	1	
2	93210-09350-00	O-RING	2	
3	93505-16024-00	BALL	1	
4	90501-12802-00	SPRING, COMPRESSION	1	
5	68D-G4122-01-00	BUSHING, SHIFT ROD LEVER	1	
6	69M-G4121-00-00	LEVER, SHIFT ROD	1	
7	69M-44126-00-00	WASHER, SHIFT ROD LEVER	1	
8	97095-05012-00	BOLT	1	
9	92995-05600-00	WASHER	1	
10	69M-44143-00-00	ROD, SHIFT	1	
11	92990-05600-00	WASHER, PLATE	1	
12	91490-16010-00	PIN. COTTER	1	
13	6N0-G4145-10-00	CONNECTOR, SHIFT ROD	1	
14	6N0-G4146-10-00	CONNECTOR, SHIFT ROD	1	
15	90119-06ME0-00	BOLT, WITH WASHER	1	
16	6L5-44144-00-00	ROD, SHIFT	1	S(17.0")
17	91609-25014-00	PIN, SPRING	1	

F2.5MSH 0406 / BRACKET

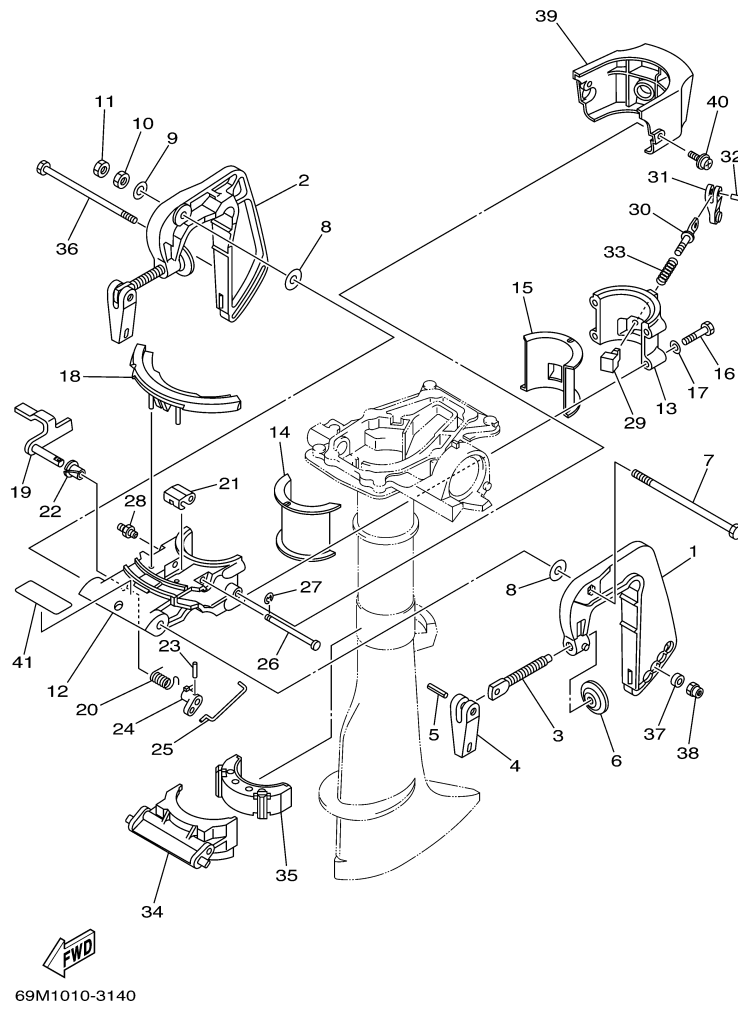

©2014 Yamaha Motor Corporation, U.S.A. All rights reserved.

Part List

F2.5MSH 0406 / BRACKET

REF - NO	PART NUMBER	PART NAME	QUANTITY	REMARKS
1	69M-G3111-00-4D	BRACKET, CLAMP 1	1	
2	69M-G3112-00-4D	BRACKET, CLAMP 2	1	
3	6E0-43116-01-00	SCREW, TRANSOM CLAMP	2	
4	69M-G3118-00-00	HANDLE, TRANSOM CLAMP	2	
5	90243-04M01-00	PIN	2	
6	620-43114-00-00	PAD, TRANSOM CLAMP	2	
7	90101-08M07-00	BOLT	1	
8	90202-08022-00	WASHER, PLATE	2	
9	92990-08200-00	WASHER, PLAIN	1	
10	95380-08600-00	NUT	1	
11	95380-08700-00	NUT	1	
12	69M-G3311-01-4D	BRACKET, SWIVEL 1	1	
13	69M-G3312-00-4D	BRACKET, SWIVEL 2	1	
14	69M-G2537-00-00	BUSHING, PIVOT SHAFT	1	
15	69M-G2538-00-00	BUSHING, PIVOT SHAFT	1	
16	97075-06030-00	BOLT	4	
17	92995-06600-00	WASHER	4	
18	69M-43679-00-00	STOPPER, HOOK	1	
19	69M-43180-00-00	TILT STOP LEVER ASSY	1	
20	69M-G3188-00-00	SPRING	1	
21	69M-G3186-00-00	LEVER	1	
22	90386-08032-00	BUSH	1	
23	91690-20010-00	PIN, SPRING	1	
24	69M-G3185-00-00	LEVER, TILT STOP 2	1	
25	69M-G3164-00-00	ROD, TILT LOCK	1	
26	69M-G3166-00-00	PIN	1	
27	99080-04600-00	CIRCLIP	1	
28	93700-06M03-00	NIPPLE, GREASE	1	
29	69M-42528-00-00	PLATE, FRICTION	1	
30	69M-42529-00-00	SCREW, FRICTION PIECE	1	
31	68D-G2561-01-00	KNOB, STEERING LOCK	1	
32	90266-04M05-00	RIVET	1	
33	90501-12803-00	SPRING, COMPRESSION	1	
34	69M-G3351-00-00	RECEIVER, THRUST	1	
35	69M-44557-00-00	MOUNT DAMPER, LOWER FRONT	1	
36	90101-06030-00	BOLT	1	
37	90201-06040-00	WASHER, PLATE	1	
38	95780-06300-00	NUT, FLANGE	1	
39	69M-G3318-00-00	COVER	1	
40	90159-06M11-00	SCREW, WITH WASHER	2	
41	69M-G3691-00-00	INDICATOR, TILT	1	

F2.5MSH 0406 / UPPER CASING

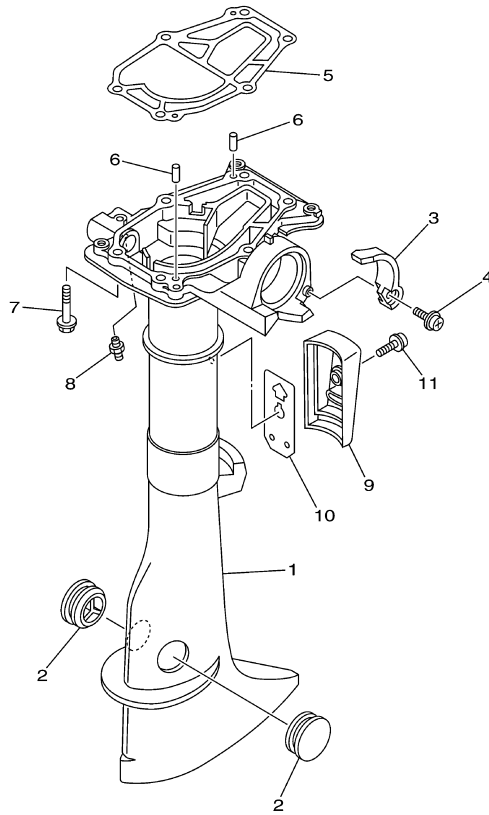

69M2110-C150

Part List

F2.5MSH 0406 / UPPER CASING

REF - NO	PART NUMBER	PART NAME	QUANTITY	REMARKS
1	69M-G5111-00-4D	CASING, UPPER	1	
2	647-45151-01-00	COVER, UPPER CASING	2	
3	69M-G5152-00-00	COVER, UPPER CASING 2	1	
4	90159-05M12-00	SCREW, WITH WASHER	1	
5	69M-45113-A0-00	.GASKET, UPPER CASING	1	
6	93604-12M07-00	PIN, DOWEL	2	
7	97575-06535-00	BOLT, WITH WASHER	6	
8	93700-06M03-00	NIPPLE, GREASE	1	
9	69M-G5151-00-00	COVER, UPPER CASING	1	
10	69M-G5115-00-00	.GASKET, UPPER CASING	1	
11	90159-06M11-00	SCREW, WITH WASHER	1	

F2.5MSH 0406 / LOWER CASING DRIVE 1

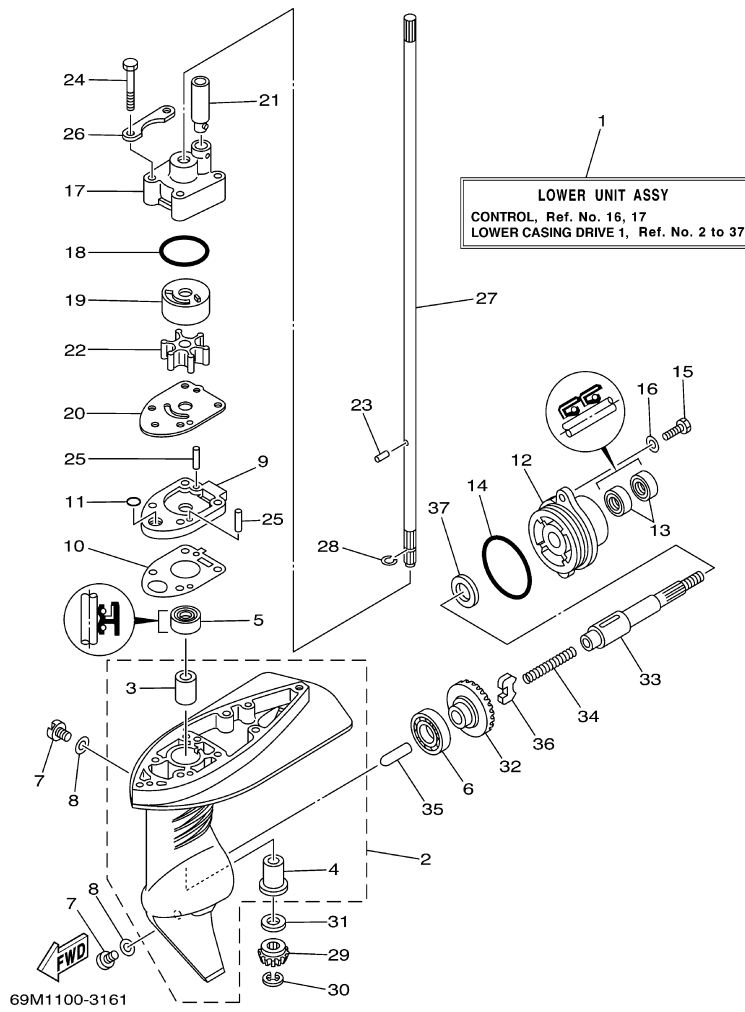

©2014 Yamaha Motor Corporation, U.S.A. All rights reserved.

Part List

F2.5MSH 0406 / LOWER CASING DRIVE 1

REF - NO	PART NUMBER	PART NAME	QUANTITY	REMARKS
1	69M-G5300-01-4D	LOWER UNIT ASSY	1	S (17.0")
2	69M-G5311-00-4D	CASING, LOWER	1	
3	6L5-45316-09-00	.BUSHING, DRIVE SHAFT	1	
4	6L5-45317-09-00	.BUSHING, DRIVE SHAFT	1	
5	93103-09M41-00	.OIL SEAL	1	
6	93316-003Y0-00	BEARING	1	
7	90340-08002-00	PLUG, STRAIGHT SCREW	2	
8	90430-08020-00	.GASKET	2	
9	69M-G5321-00-94	PLATE	1	
10	69M-G5315-A0-00	.PACKING, LOWER CASING	1	
11	93210-05001-00	.O-RING	1	
12	69M-G5361-00-4D	CAP, LOWER CASING	1	
13	93101-13M12-00	.OIL SEAL	2	
14	93210-48214-00	.O-RING	1	
15	97095-06016-00	BOLT	2	
16	92995-06600-00	WASHER	2	
17	69M-G4311-00-00	HOUSING, WATER PUMP	1	
18	93210-33M85-00	.O-RING	1	
19	6L5-44322-00-00	.INSERT, CARTRIDGE	1	
20	69M-G4323-00-00	.OUTER PLATE, CARTRIDGE	1	
21	6E0-44366-00-00	DAMPER, WATER SEAL 2	1	
22	6L5-44352-00-00	.IMPELLER	1	
23	93604-07M13-00	PIN, DOWEL	1	
24	97095-06040-00	.BOLT	4	
25	93604-18080-00	.PIN, DOWEL	2	
26	69M-G4328-00-00	.PLATE	2	
27	69M-G5511-00-00	SHAFT, DRIVE	1	S (17.0")
28	93440-08819-00	CIRCLIP	1	
29	69M-G5551-00-00	PINION (13T)	1	
30	99001-06600-00	CIRCLIP	1	
31	6L5-45533-00-21	SHIM (T:2.1MM)	1	UR
31	6L5-45533-00-20	SHIM (T:2.0MM)	1	UR
31	6L5-45533-00-22	SHIM (T:2.2MM)	1	UR
31	6L5-45533-00-23	SHIM (T:2.3MM)	1	UR
32	69M-G5560-00-00	GEAR 1 (27T)	1	
33	69M-G5611-00-00	SHAFT, PROPELLER	1	
34	90501-10064-00	SPRING, COMPRESSION	1	
35	69M-G5635-00-00	PLUNGER, SHIFT	1	
36	6L5-45631-00-00	CLUTCH, DOG	1	
37	90201-13198-00	WASHER, PLATE	1	

Part Notes

F2.5MSH 0406 / LOWER CASING DRIVE 1

PART NUMBER	NOTE TEXT
90430-08020-00 	OEM: This part number is among the Top 100 Most Popular Marine Maintenance Parts as of March 2014.

©2014 Yamaha Motor Corporation, U.S.A. All rights reserved.

F2.5MSH 0406 / LOWER CASING DRIVE 2

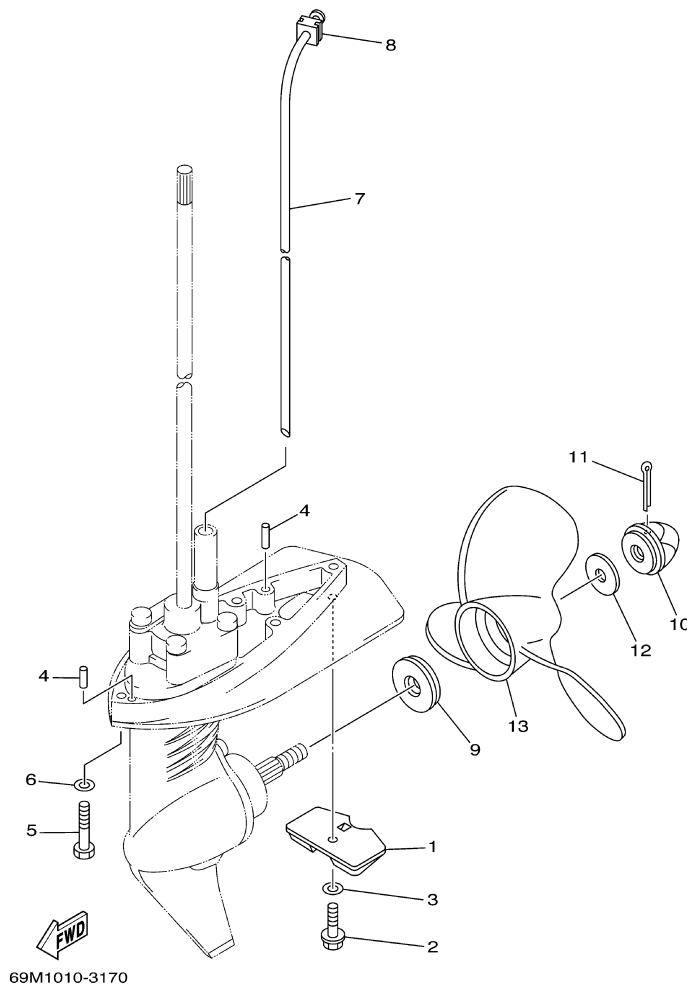

69M1010-3170

Part List

F2.5MSH 0406 / LOWER CASING DRIVE 2

REF - NO	PART NUMBER	PART NAME	QUANTITY	REMARKS
1	68D-G5251-00-00	ANODE	1	
2	95895-06020-00	BOLT, FLANGE	1	
3	92990-06300-00	WASHER, INTERNAL TOOTH	1	
4	93604-12M07-00	PIN, DOWEL	2	
5	97095-06030-00	BOLT	3	S (17.0")
6	92995-06600-00	WASHER	3	S (17.0")
7	69M-44361-00-00	TUBE, WATER 1	1	S (17.0")
8	68D-G4365-00-00	.DAMPER, WATER SEAL 1	1	
9	68D-G5987-00-00	SPACER 1	1	
10	6L5-45616-00-00	NUT, PROPELLER	1	
11	91490-25030-00	PIN. COTTER	1	
12	90201-08M54-00	WASHER, PLATE	1	
13	6L5-45949-00-EL	PROPELLER (3X7-1/4"X5"-BS)	1	UR
13	6L5-45943-00-EL	PROPELLER (3X7-1/4"X6"-BS)	1	UR
13	6L5-45947-00-EL	PROPELLER (3X7-1/4"X8-1/4"-BS)	1	UR
13	6L5-45945-00-EL	PROPELLER (3X7-1/4"X7-1/4"-BS)	1	UR
13	6L5-45952-00-EL	PROPELLER (3X7-1/4"X5-1/2"-BS)	1	UR

F2.5MSH 0406 / REPAIR KIT 1

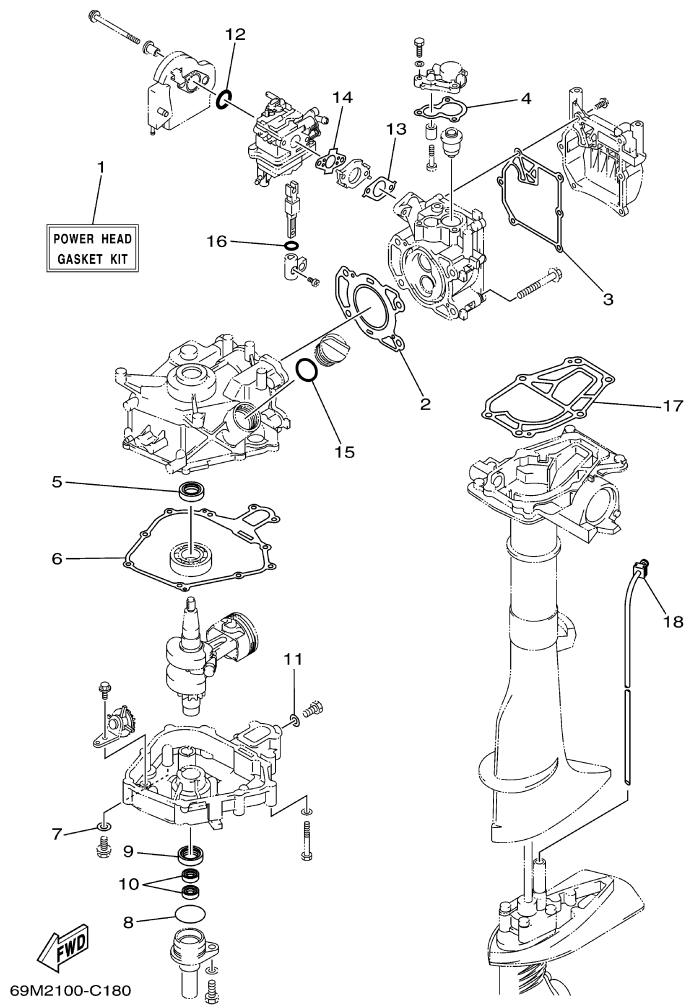

©2014 Yamaha Motor Corporation, U.S.A. All rights reserved.

Part List

F2.5MSH 0406 / REPAIR KIT 1

REF - NO	PART NUMBER	PART NAME	QUANTITY	REMARKS
1	69M-WE001-00-00	POWER HEAD GASKET KIT	1	
2	69M-11181-00-00	.GASKET, CYLINDER HEAD 1	1	
3	69M-11193-A0-00	.GASKET, HEAD COVER 1	1	
4	68D-E2414-A0-00	.GASKET, COVER	1	
5	93102-20108-00	.OIL SEAL	1	
6	69M-11351-A0-00	.GASKET, CYLINDER	1	
7	90201-08818-00	.WASHER, PLATE	1	
8	93210-35537-00	.O-RING	1	
9	93102-20108-00	.OIL SEAL	1	
10	93102-09004-00	.OIL SEAL	2	
11	90430-08800-00	.GASKET	1	
12	93210-20M65-00	.O-RING	1	
13	69M-E3645-A0-00	.GASKET, MANIFOLD 1	1	
14	69M-E3646-A0-00	.GASKET, MANIFOLD 2	1	
15	93210-24M79-00	.O-RING	1	
16	93210-13M43-00	.O-RING	1	
17	69M-45113-A0-00	.GASKET, UPPER CASING	1	
18	68D-G4365-00-00	.DAMPER, WATER SEAL 1	1	

F2.5MSH 0406 / REPAIR KIT 2

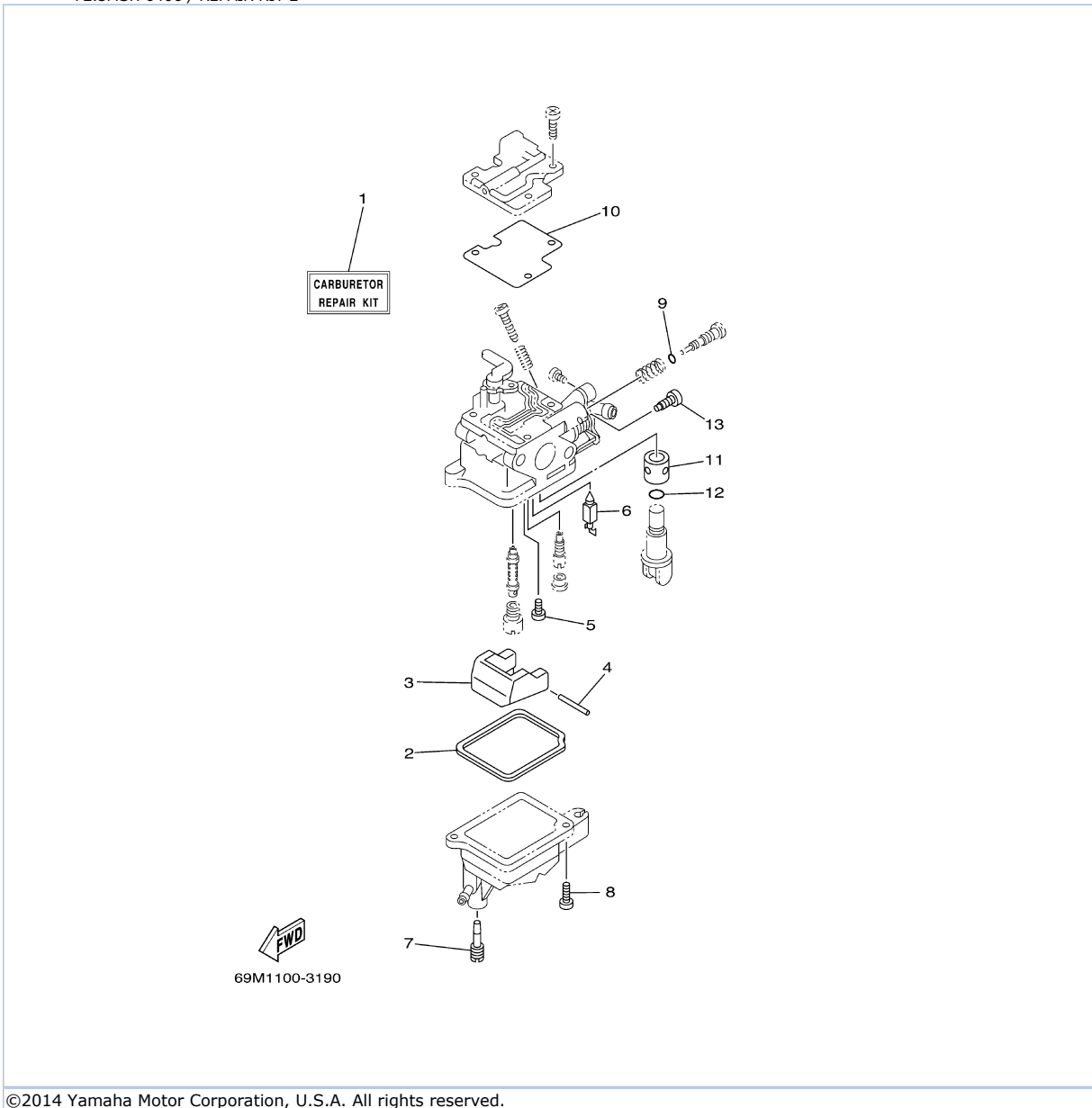

©2014 Yamaha Motor Corporation, U.S.A. All rights reserved.

Part List

F2.5MSH 0406 / REPAIR KIT 2

REF - NO	PART NUMBER	PART NAME	QUANTITY	REMARKS
1	69M-W0093-00-00	CARBURETOR REPAIR KIT	1	
2	69M-14984-00-00	.GASKET, FLOAT CHAMBER	1	
3	69M-14385-00-00	.FLOAT	1	
4	6A1-14386-00-00	.PIN, FLOAT	1	
5	98580-03005-00	.SCREW, PAN HEAD	1	
6	62Y-14392-00-00	.VALVE, NEEDLE	1	
7	69M-14991-00-00	.SCREW	1	
8	98580-04010-00	.SCREW, PAN HEAD	2	
9	2T4-14397-00-00	.O-RING	1	
10	69M-14536-00-00	.GASKET	1	
11	69M-24523-00-00	.VALVE	1	
12	69M-24533-00-00	.O-RING	1	
13	69M-24535-00-00	.SCREW, LEVER FITTING	1	

F2.5MSH 0406 / REPAIR KIT 3

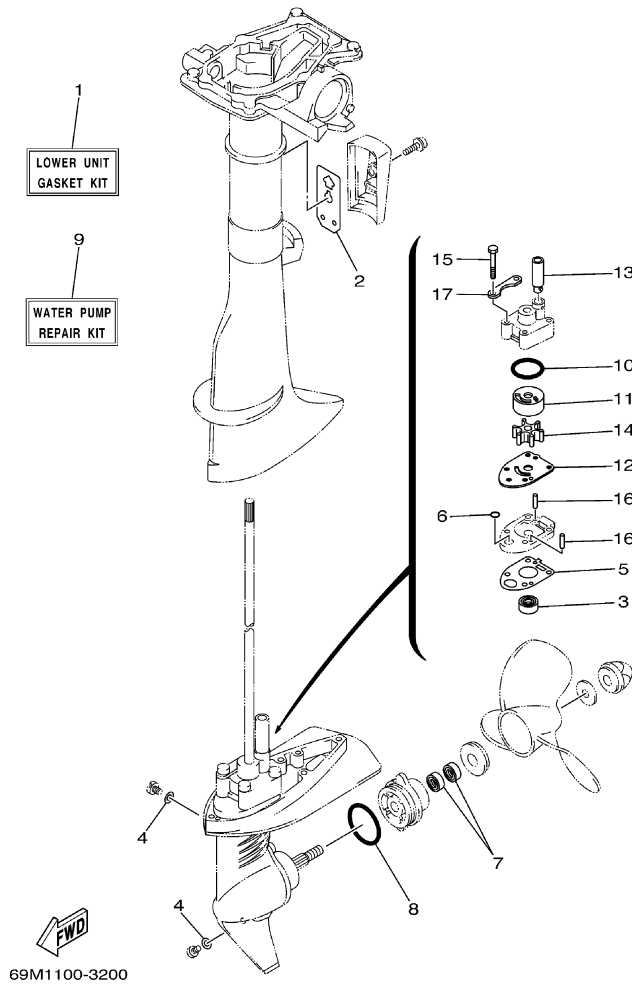

©2014 Yamaha Motor Corporation, U.S.A. All rights reserved.

Part List

F2.5MSH 0406 / REPAIR KIT 3

REF - NO	PART NUMBER	PART NAME	QUANTITY	REMARKS
1	69M-WG001-20-00	LOWER UNIT GASKET KIT	1	
2	69M-G5115-00-00	.GASKET, UPPER CASING	1	
3	93103-09M41-00	.OIL SEAL	1	
4	90430-08020-00	.GASKET	2	
5	69M-G5315-A0-00	.PACKING, LOWER CASING	1	
6	93210-05001-00	.O-RING	1	
7	93101-13M12-00	.OIL SEAL	2	
8	93210-48214-00	.O-RING	1	
9	69M-WG078-00-00	WATER PUMP REPAIR KIT	1	
10	93210-33M85-00	.O-RING	1	
11	6L5-44322-00-00	.INSERT, CARTRIDGE	1	
12	69M-G4323-00-00	.OUTER PLATE, CARTRIDGE	1	
13	6E0-44366-00-00	.DAMPER, WATER SEAL 2	1	
14	6L5-44352-00-00	.IMPELLER	1	
15	97095-06040-00	.BOLT	4	
16	93604-18080-00	.PIN, DOWEL	2	
17	69M-G4328-00-00	.PLATE	2	

Part Notes

F2.5MSH 0406 / REPAIR KIT 3

PART NUMBER	NOTE TEXT
90430-08020-00 	OEM: This part number is among the Top 100 Most Popular Marine Maintenance Parts as of March 2014.

©2014 Yamaha Motor Corporation, U.S.A. All rights reserved.

F2.5MSH 0406 / MODELS IN THIS CATALOG

F2.5MSH 69M-1033504~1040746 (69M5)

**ALL THESE MODELS USE THIS SAME PARTS CATALOG.
BE SURE TO ORDER ONLY THOSE PARTS APPLICABLE
TO THE DESIRED MODEL.**

©2014 Yamaha Motor Corporation, U.S.A. All rights reserved.

©2014 Yamaha Motor Corporation, U.S.A. All rights reserved.