

2MSHX 1999 / CYLINDER CRANKCASE

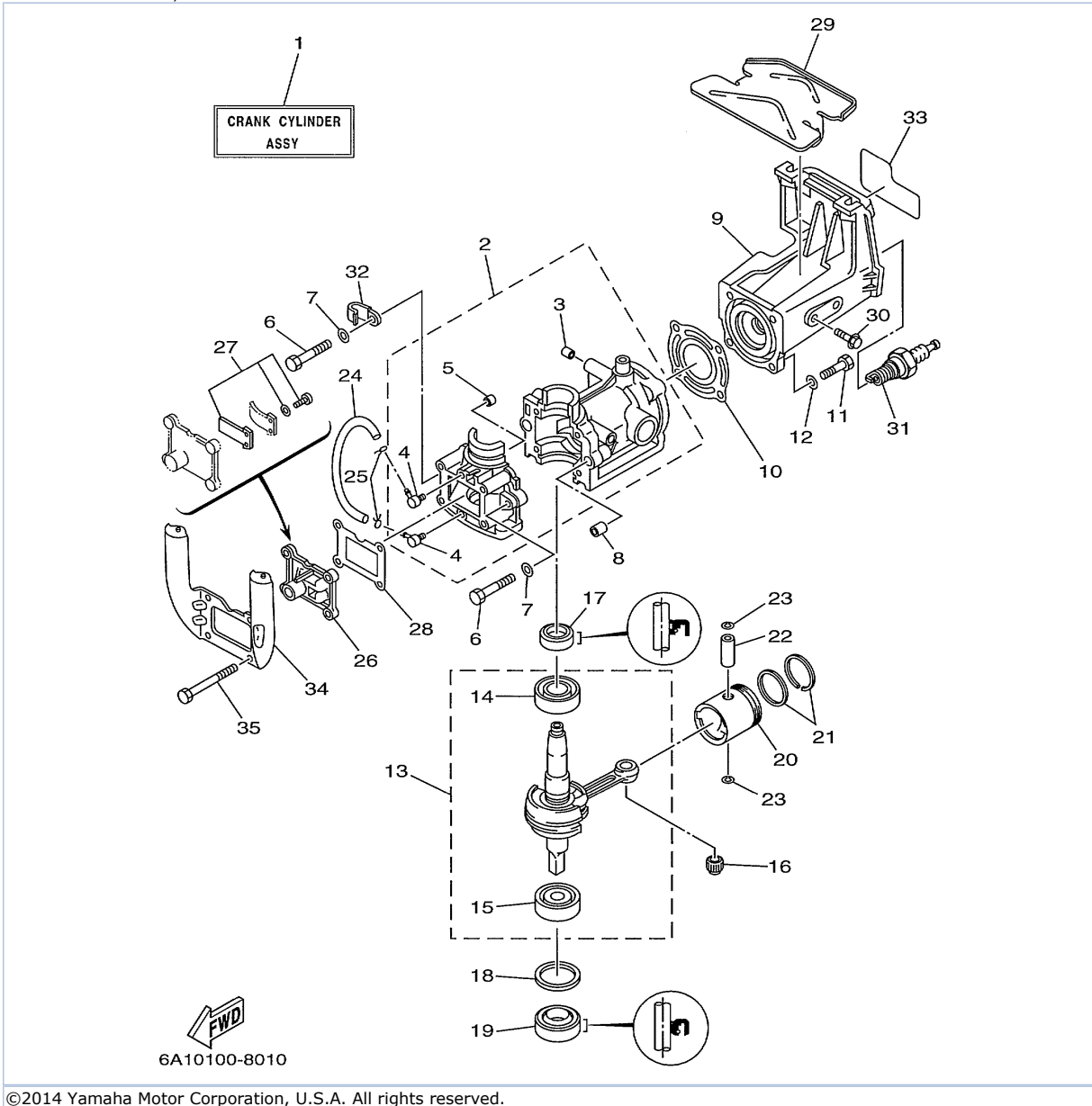

©2014 Yamaha Motor Corporation, U.S.A. All rights reserved.

## Part List

2MSHX 1999 / CYLINDER CRANKCASE

REF - NO	PART NUMBER	PART NAME	QUANTITY	REMARKS
1	6A1-W0090-13-1S	CRANK CYLINDER ASSY	1	
2	6A1-15100-61-1S	CRANKCASE ASSY	1	
3	90336-06001-00	.PLUG, TAPER	1	
4	650-14485-02-00	.PIPE, JOINT	2	
5	624-11379-00-00	.VALVE, CHECK	1	
6	97013-06040-00	BOLT	2	
7	92903-06600-00	WASHER, PLATE	2	
8	99530-10014-00	PIN, DOWEL	2	
9	6A1-11111-02-1S	HEAD, CYLINDER 1	1	
10	6A1-11181-A1-00	.GASKET, CYLINDER HEAD 1	1	
11	97095-06025-00	BOLT	4	
12	92995-06600-00	WASHER	4	
13	6A1-11400-00-00	CRANKSHAFT ASSY	1	
14	93306-00409-00	.BEARING	1	
15	93306-30204-00	.BEARING	1	
16	93310-210V1-00	BEARING	1	
17	93102-20070-00	.OIL SEAL	1	
18	90201-35300-00	WASHER, PLATE	1	
19	93102-15M32-00	.OIL SEAL	1	
20	646-11631-01-98	PISTON (STD)	1	
20	646-11636-01-00	PISTON (0.50MM O/S)	1	AP
21	646-11601-01-00	PISTON RING SET (STD)	1	
21	646-11601-21-00	PISTON RING SET (0.50MM O/S)	1	AP
22	646-11633-00-00	PIN, PISTON	1	
23	93450-11021-00	CIRCLIP	2	
24	90445-07254-00	HOSE (L118)	1	
25	90467-06016-00	CLIP	2	
26	6A1-13610-00-00	REED VALVE ASSY	1	
27	6A1-W0004-00-00	.REED SET	1	
28	6A1-13621-A0-00	.GASKET, VALVE SEAT	1	
29	6A1-24141-00-00	PROTECTOR, FUEL TANK	1	
30	95895-06010-00	BOLT, FLANGE	2	
31	NGK-B5HS0-00-00	PLUG, SPARK (NGK B5HS)	1	
32	90465-08M75-00	CLAMP	1	
33	6A1-42678-12-00	GRAPHIC, REAR	1	
34	6A1-15771-01-00	STAY 1	1	
35	97013-06060-00	BOLT	4	

2MSHX 1999 / CARBURETOR

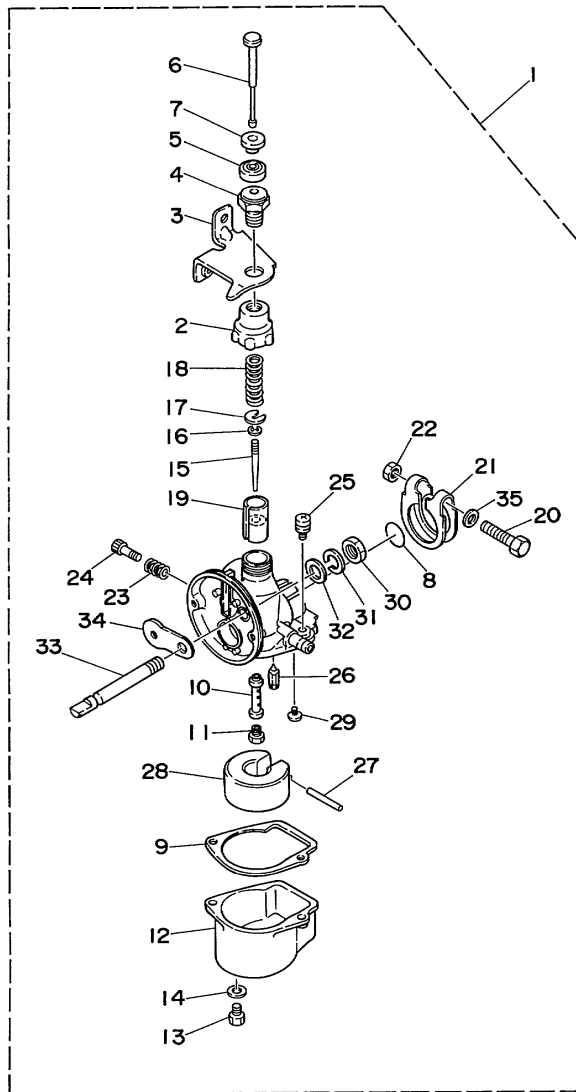

6A10010-4020

©2014 Yamaha Motor Corporation, U.S.A. All rights reserved.

## Part List

2MSHX 1999 / CARBURETOR

REF - NO	PART NUMBER	PART NAME	QUANTITY	REMARKS
1	6A1-14301-03-00	CARBURETOR ASSY 1	1	
2	646-14158-00-00	.TOP, MIXING CHAMBER	1	
3	6A1-14497-00-00	.STAY, THROTTLE WIRE	1	
4	646-14321-00-00	.SCREW, THROTTLE	1	
5	646-14169-00-00	.CAP	1	
6	6A1-14314-00-00	.BAR, THROTTLE	1	
7	6A1-14163-00-00	.SPACER	1	
8	646-14229-01-00	.O-RING	1	
9	6A1-14384-00-00	.GASKET, FLOAT CHAMBER	1	
10	6A1-14341-01-00	.NOZZLE, MAIN	1	
11	6A1-14343-48-00	.JET, MAIN (# 96)	1	
12	6A1-14381-02-00	.BODY, FLOAT CHAMBER	1	
13	97890-05006-00	.SCREW, PAN HEAD	1	
14	646-14198-01-00	.GASKET	1	
15	6A1-14116-10-00	.NEEDLE	1	
16	646-14137-00-00	.CLIP	1	
17	646-14136-00-00	.SEAT, SPRING	1	
18	646-14331-01-00	.SPRING, THROTTLE VALVE	1	
19	646-14312-08-00	.VALVE, THROTTLE 1	1	
20	6A1-14125-01-00	.SCREW	1	
21	6A1-14127-01-00	.CLIP	1	
22	6A1-14358-01-00	.NUT	1	
23	6A1-14212-00-00	.SPRING, PILOT ADJUSTING	1	
24	646-14211-02-00	.SCREW, PILOT ADJUSTING	1	
25	97980-04110-00	.SCREW, WITH WASHER	2	
26	6A1-14392-00-00	.VALVE, NEEDLE	1	
27	6A1-14386-00-00	.PIN, FLOAT	1	
28	6A1-14385-00-00	.FLOAT	1	
29	98580-03005-00	.SCREW, PAN HEAD	1	
30	646-14358-00-00	.NUT	1	
31	6A1-14356-00-00	.WASHER, SPRING	1	
32	646-14357-00-00	.WASHER, PLAIN	1	
33	6A1-14448-00-00	.LEVER, CHOKE VALVE	1	
34	6A1-14217-01-00	.VALVE, CHOKE	1	
35	92990-05600-00	.WASHER, PLATE	1	

2MSHX 1999 / STARTER

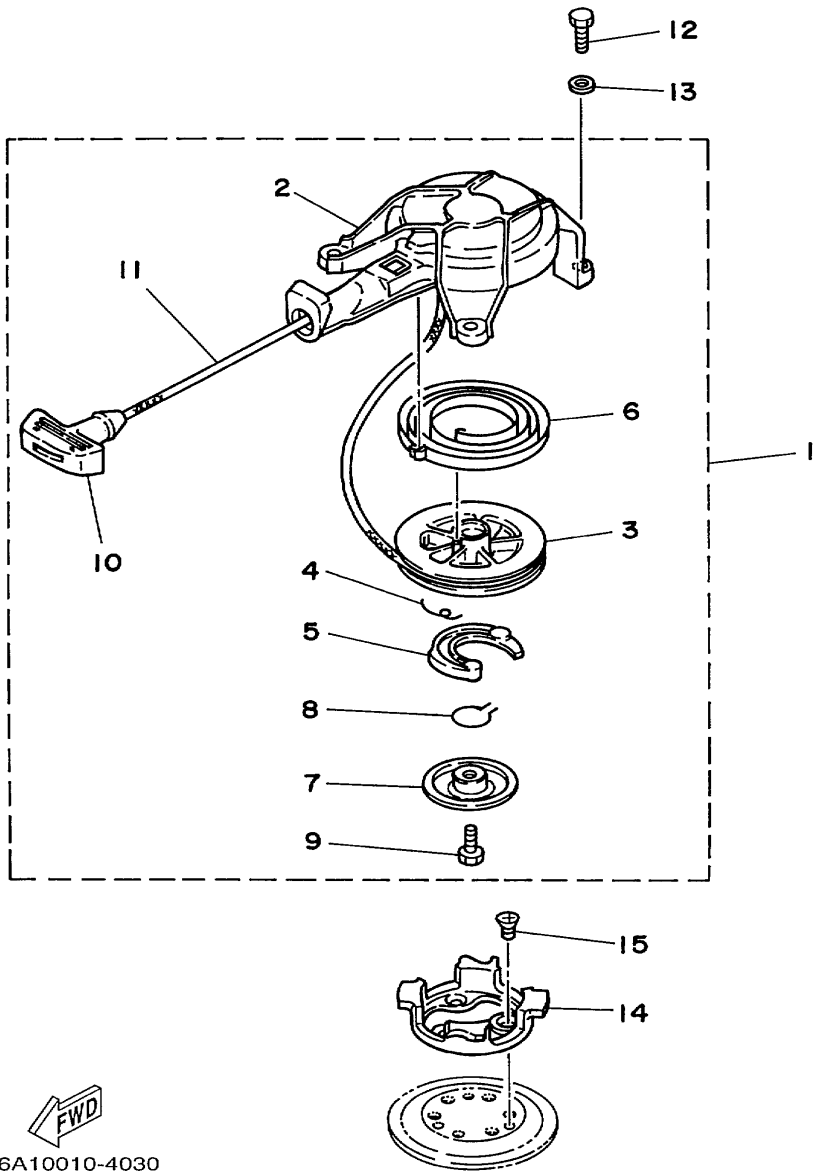

  
6A10010-4030

©2014 Yamaha Motor Corporation, U.S.A. All rights reserved.

## Part List

2MSHX 1999 / STARTER

REF - NO	PART NUMBER	PART NAME	QUANTITY	REMARKS
1	6A1-15710-00-00	STARTER ASSY	1	
2	6A1-15711-00-00	.CASE, STARTER	1	
3	6A1-15714-00-00	.DRUM, SHEAVE	1	
4	6A1-15767-00-00	.SPRING	1	
5	6A1-15741-00-00	.PAWL, DRIVE	1	
6	6A1-15713-00-00	.SPRING, STARTER	1	
7	6A1-15717-00-00	.SHAFT, STARTER	1	
8	6A1-15705-00-00	.SPRING, DRIVE PAWL	1	
9	97322-06012-00	.BOLT	1	
10	6A1-15755-01-00	.HANDLE, STARTER	1	
11	90580-40M02-00	.ROPE, STARTER	1	
12	97095-06016-00	BOLT	3	
13	92995-06600-00	WASHER	3	
14	6A1-15723-00-94	PULLEY, STARTER	1	
15	98703-06012-00	SCREW, FLAT HEAD	3	

2MSHX 1999 / COWLING FUEL

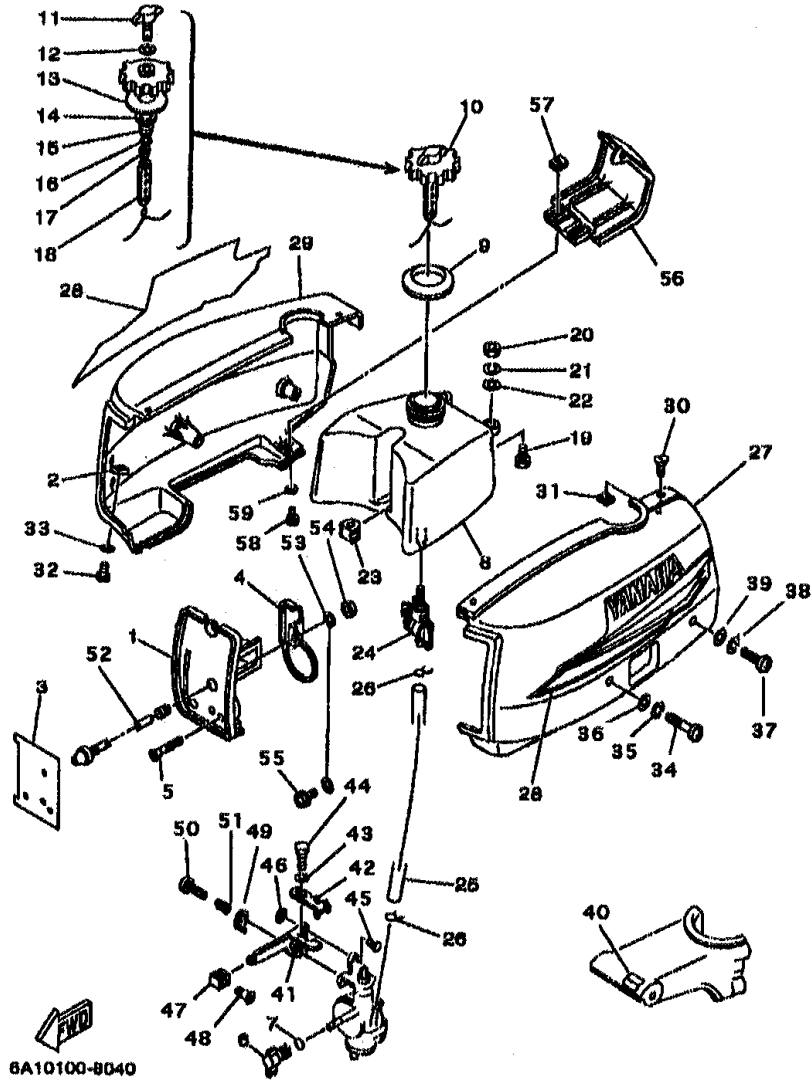

©2014 Yamaha Motor Corporation, U.S.A. All rights reserved.

## Part List



2MSHX 1999 / COWLING FUEL

REF - NO	PART NUMBER	PART NAME	QUANTITY	REMARKS
1	6A1-14441-02-00	SILENCER, INTAKE 2	1	
2	90173-05M00-00	NUT, SQUARE	2	
3	6A1-42677-01-00	GRAPHIC, FRONT	1	
4	6A1-14442-00-00	SPACER	1	
5	98780-04035-00	SCREW, FLAT HEAD	2	
6	6A1-41271-00-00	KNOB, CHOKE	1	
7	93210-08M29-00	.O-RING	1	
8	6A1-24110-01-00	FUEL TANK COMP.	1	
9	6A1-24198-00-00	SEAT, RUBBER	1	
10	6A1-24610-01-00	CAP ASSY	1	
11	6A1-24631-00-00	.SCREW, AIR	1	
12	90430-04005-00	.GASKET	1	
13	90430-14117-00	.GASKET	1	
14	646-24615-01-00	.GASKET, PLATE 1	1	
15	90501-10374-00	.SPRING, COMPRESSION	1	
16	92907-04200-00	.WASHER	1	
17	90501-10260-00	.SPRING, COMPRESSION	1	
18	646-24241-00-00	.INDICATOR 1	1	
19	97095-06018-00	.BOLT	2	
20	95380-06600-00	NUT, HEXAGON	2	
21	92995-06100-00	WASHER, SPRING	2	
22	90201-06M30-00	WASHER, PLATE	2	
23	6A1-24181-00-00	DAMPER, LOCATING 1	1	
24	6A1-24500-02-00	FUEL COCK ASSY 1	1	
25	6A1-24311-00-00	PIPE, FUEL 1	1	
26	90467-08004-00	CLIP	2	
27	6A1-42741-11-00	APRON	1	
28	6A1-W0070-14-00	GRAPHIC SET	1	
29	6A1-42771-11-00	APRON	1	
30	98780-05012-00	SCREW, FLAT HEAD	2	
31	90183-05M00-00	NUT, SPRING	2	
32	97880-05010-00	SCREW, PAN HEAD	2	
33	92990-05600-00	WASHER, PLATE	2	
34	97880-06040-00	SCREW, PAN HEAD	2	
35	92990-06100-00	.WASHER, SPRING	2	
36	92990-06600-00	.WASHER, PLATE	2	
37	97880-06025-00	SCREW, PAN HEAD	2	
38	92990-06100-00	.WASHER, SPRING	2	
39	92990-06600-00	.WASHER, PLATE	2	
40	6A1-42792-01-00	MARK (100:1)	1	
41	6A1-41212-01-00	ARM, ACCEL.	1	
42	6A1-41211-00-00	LINK, ACCEL.	1	
43	92990-05100-00	.WASHER, SPRING	1	
44	97095-05010-00	BOLT	1	
45	6A1-14365-00-00	PIN, CLEVIS	1	
46	93430-04003-00	CIRCLIP	1	
47	6A1-41637-00-00	KNOB, MAGNETO CONTROL	1	
48	98780-03010-00	SCREW, FLAT HEAD	1	
49	6A1-41223-00-00	WASHER, LOCK 1	1	
50	97885-05025-00	SCREW, PAN HEAD	1	
51	90501-12M16-00	SPRING, COMPRESSION	1	
52	6A1-82550-02-00	ENGINE STOP SWITCH ASSY	1	
53	6A1-82541-00-00	WIRE, LEAD	1	
54	95380-08700-00	.NUT	1	
55	97880-05008-00	SCREW, PAN HEAD	1	
56	6A1-82375-11-00	COVER, PLUG CAP	1	
57	90183-05M00-00	NUT, SPRING	2	
58	97880-05012-00	SCREW, PAN HEAD	2	
59	92990-05600-00	WASHER, PLATE	2	



## Part Notes

2MSHX 1999 / COWLING FUEL

PART NUMBER		NOTE TEXT
92990-06600-00		OEM: This part number is among the Top 100 Most Popular Marine Maintenance Parts as of March 2014.
92990-06600-00		OEM: This part number is among the Top 100 Most Popular Marine Maintenance Parts as of March 2014.

©2014 Yamaha Motor Corporation, U.S.A. All rights reserved.

2MSHX 1999 / BRACKET 1

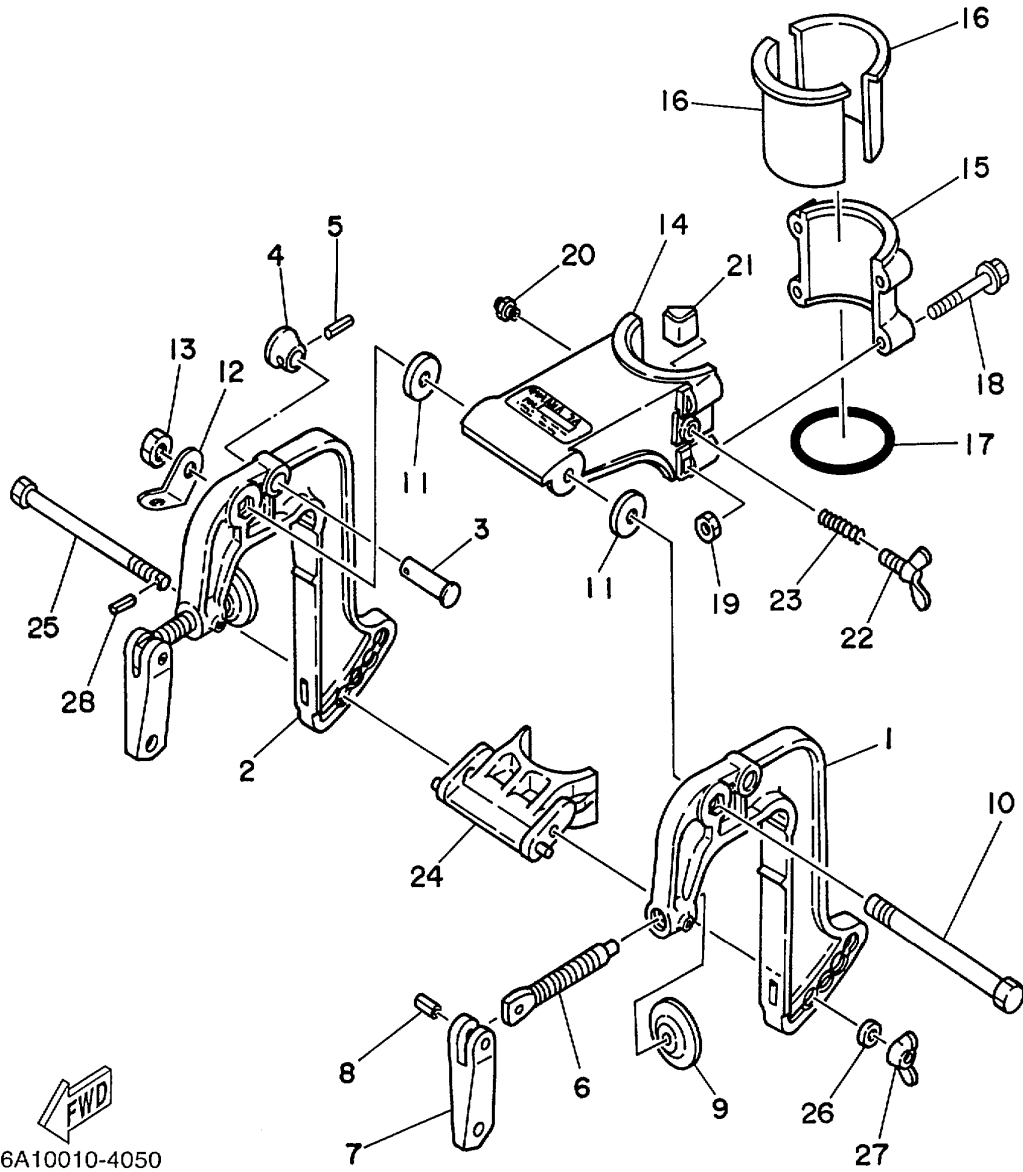

6A10010-4050

©2014 Yamaha Motor Corporation, U.S.A. All rights reserved.

## Part List

2MSHX 1999 / BRACKET 1

REF - NO	PART NUMBER	PART NAME	QUANTITY	REMARKS
1	6A1-43111-03-4D	BRACKET, CLAMP	1	
2	6A1-43112-00-4D	BRACKET, CLAMP	1	
3	6A1-43191-00-00	SHAFT, STOPPER	1	
4	6A1-43192-00-00	KNOB, STOPPER	1	
5	91690-30014-00	PIN, SPRING	1	
6	6E0-43116-01-00	SCREW, TRANSOM CLAMP	2	
7	6E0-43118-01-00	HANDLE, TRANSOM CLAMP	2	
8	90243-04M01-00	PIN	2	
9	620-43114-00-00	PAD, TRANSOM CLAMP	2	
10	90101-08217-00	BOLT	1	
11	90202-08022-00	WASHER, PLATE	2	
12	6A1-43113-01-00	PLATE, CLAMP BRACKET	1	
13	95380-08600-00	NUT	1	
14	6A1-43311-02-4D	BRACKET, SWIVEL 1	1	
15	6A1-43312-00-4D	BRACKET, SWIVEL 2	1	
16	646-42537-01-00	BUSHING, PIVOT SHAFT	2	
17	93210-46044-00	O-RING	1	
18	90119-06M98-00	BOLT, WITH WASHER	4	
19	95380-06600-00	NUT, HEXAGON	4	
20	93700-06M03-00	NIPPLE, GREASE	1	
21	646-42528-00-00	PLATE, FRICTION	1	
22	90122-06004-00	BOLT, WING	1	
23	90501-12272-00	SPRING, COMPRESSION	1	
24	6A1-43351-00-00	RECEIVER, THRUST	1	
25	6A1-43371-00-00	BOLT, RECEIVER	1	
26	90201-06040-00	WASHER, PLATE	1	
27	90175-06008-00	NUT, WING	1	
28	91690-20006-00	PIN, SPRING	1	

2MSHX 1999 / UPPER CASING

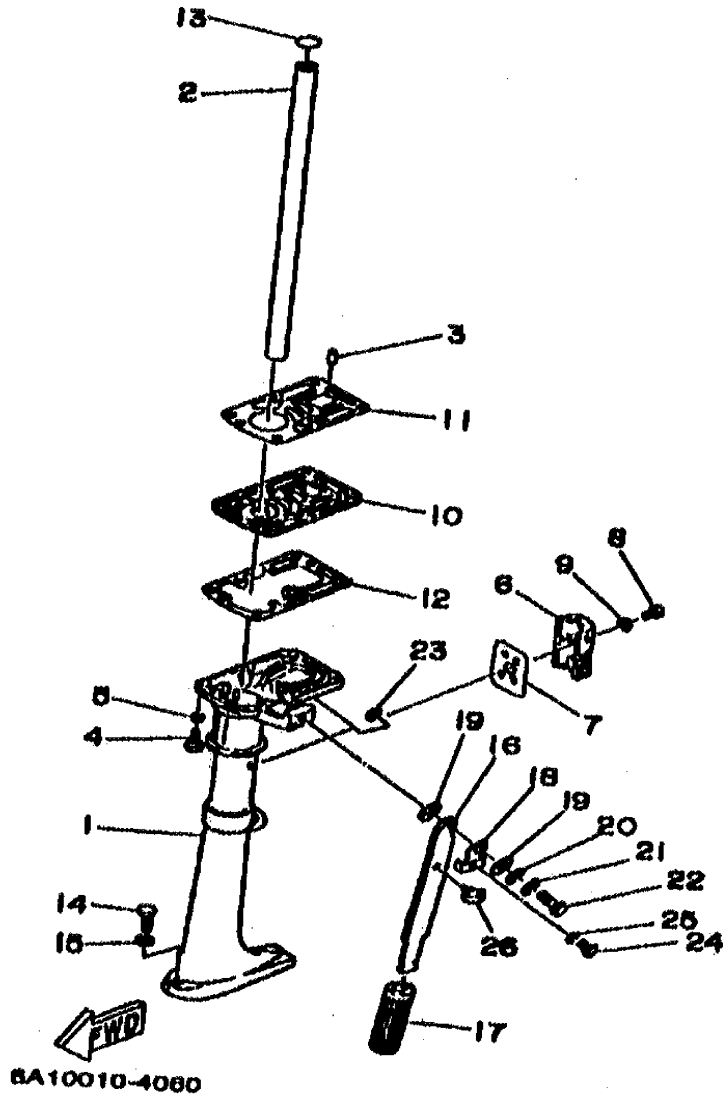

©2014 Yamaha Motor Corporation, U.S.A. All rights reserved.



## Part List

2MSHX 1999 / UPPER CASING

REF - NO	PART NUMBER	PART NAME	QUANTITY	REMARKS
1	6A1-45111-02-4D	CASING, UPPER	1	
2	6A1-45113-00-00	GASKET, UPPER CASING	1	
3	93605-15065-00	PIN, DOWEL	2	
4	97095-06025-00	BOLT	6	
5	92995-06600-00	WASHER	6	
6	6A1-45151-00-00	COVER, UPPER CASING	1	
7	6A1-45115-00-00	GASKET, UPPER CASING	1	
8	97880-06016-00	SCREW, PAN HEAD	1	
9	92990-06600-00	.WASHER, PLATE	1	
10	6A1-41137-00-5B	GUIDE, EXHAUST	1	
11	6A1-14613-A0-00	.GASKET, EXHAUST PIPE	1	
12	646-14623-A1-00	.GASKET, EXHAUST PIPE	1	
13	93210-19123-00	O-RING	1	
14	97095-06030-00	.BOLT	1	
15	92990-06600-00	.WASHER, PLATE	1	
16	6A1-42111-00-4D	HANDLE, STEERING	1	
17	646-42119-02-00	GRIP, STEERING HANDLE	1	
18	6A1-42181-00-00	WASHER	1	
19	90201-09117-00	WASHER, PLATE	2	
20	92990-08200-00	WASHER, PLAIN	1	
21	92990-08100-00	WASHER, SPRING	1	
22	90101-08M11-00	BOLT	1	
23	95380-08600-00	NUT	1	
24	97095-06010-00	BOLT	1	
25	92995-06100-00	WASHER, SPRING	1	
26	646-42591-00-00	HOLDER, SHEAR PIN	1	

## Part Notes

2MSHX 1999 / UPPER CASING

PART NUMBER	NOTE TEXT
92990-06600-00 	OEM: This part number is among the Top 100 Most Popular Marine Maintenance Parts as of March 2014.
92990-06600-00 	OEM: This part number is among the Top 100 Most Popular Marine Maintenance Parts as of March 2014.

©2014 Yamaha Motor Corporation, U.S.A. All rights reserved.

2MSHX 1999 / LOWER CASING DRIVE 1

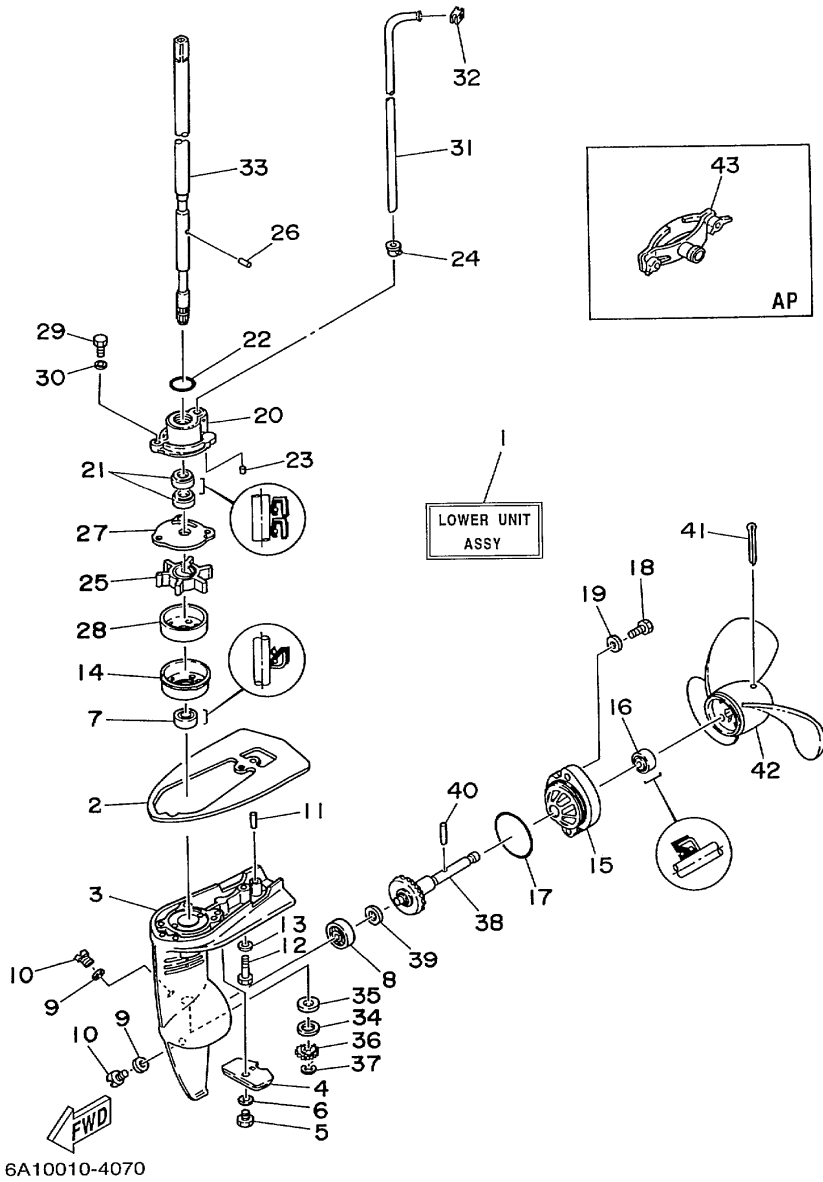

6A10010-4070

©2014 Yamaha Motor Corporation, U.S.A. All rights reserved.



## Part List

2MSHX 1999 / LOWER CASING DRIVE 1

REF - NO	PART NUMBER	PART NAME	QUANTITY	REMARKS
1	6A1-45300-03-4D	LOWER UNIT ASSY	1	
2	6A1-45181-00-4D	PLATE	1	
3	6A1-45311-02-4D	CASING, LOWER	1	
4	6L5-45251-02-00	ANODE	1	
5	95895-06012-00	BOLT, FLANGE	1	
6	92990-06300-00	WASHER, INTERNAL TOOTH	1	
7	93103-11051-00	.OIL SEAL	1	
8	93306-00001-00	..BEARING	1	
9	90430-08020-00	.GASKET	2	
10	90340-08M04-00	PLUG, STRAIGHT SCREW	2	
11	93605-18M04-00	PIN, DOWEL	2	
12	97095-06030-00	.BOLT	2	
13	92995-06600-00	WASHER	2	
14	6A1-44325-00-00	.PROTECTOR, OIL SEAL	1	
15	6A1-45361-01-4D	CAP, LOWER CASING	1	
16	93103-10052-00	.OIL SEAL	1	
17	93210-42101-00	.O-RING	1	
18	97090-06014-00	BOLT	2	
19	92990-06600-00	.WASHER, PLATE	2	
20	6A1-44312-01-94	COVER, WATER PUMP HOUSING	1	
21	93101-11M44-00	.OIL SEAL	2	
22	93210-19123-00	O-RING	1	
23	93604-09068-00	.PIN, DOWEL	2	
24	646-44366-01-00	.DAMPER, WATER SEAL	1	
25	646-44352-01-00	.IMPELLER	1	
26	93604-09066-00	PIN, DOWEL	1	
27	646-44323-00-00	.OUTER PLATE, CARTRIDGE	1	
28	646-44322-00-00	.INSERT, CARTRIDGE	1	
29	97095-05016-00	.BOLT	2	
30	92995-05600-00	WASHER	2	
31	6A1-44361-00-00	TUBE, WATER	1	
32	646-44365-00-00	DAMPER, WATER SEAL	1	
33	6A1-45510-01-00	DRIVE SHAFT ASSY	1	
34	90201-11M49-00	WASHER, PLATE	1	
35	646-45534-00-04	SHIM (T:0.40MM)	1	UR
35	646-45534-00-03	SHIM (T:0.30MM)	1	UR
35	646-45534-00-05	SHIM (T:0.50MM)	1	UR
36	646-45551-00-00	PINION	1	
37	93430-06005-00	CIRCLIP	1	
38	646-45560-00-00	GEAR	1	
39	646-45567-00-04	SHIM (T:0.40MM)	1	UR
39	646-45567-00-05	SHIM (T:0.50MM)	1	UR
39	646-45567-00-03	SHIM (T:0.30MM)	1	UR
40	90250-03M10-00	PIN, STRAIGHT	1	
41	91490-30040-00	PIN, COTTER	1	
42	6A1-45943-00-00	PROPELLER (PLASTIC 4 X 7- 1/4"-A)	1	UR
43	646-28193-00-00	PLUG, WATER CHECK	1	AP

## Part Notes

2MSHX 1999 / LOWER CASING DRIVE 1

PART NUMBER	NOTE TEXT
90430-08020-00 	OEM: This part number is among the Top 100 Most Popular Marine Maintenance Parts as of March 2014.
92990-06600-00 	OEM: This part number is among the Top 100 Most Popular Marine Maintenance Parts as of March 2014.

©2014 Yamaha Motor Corporation, U.S.A. All rights reserved.

2MSHX 1999 / GENERATOR

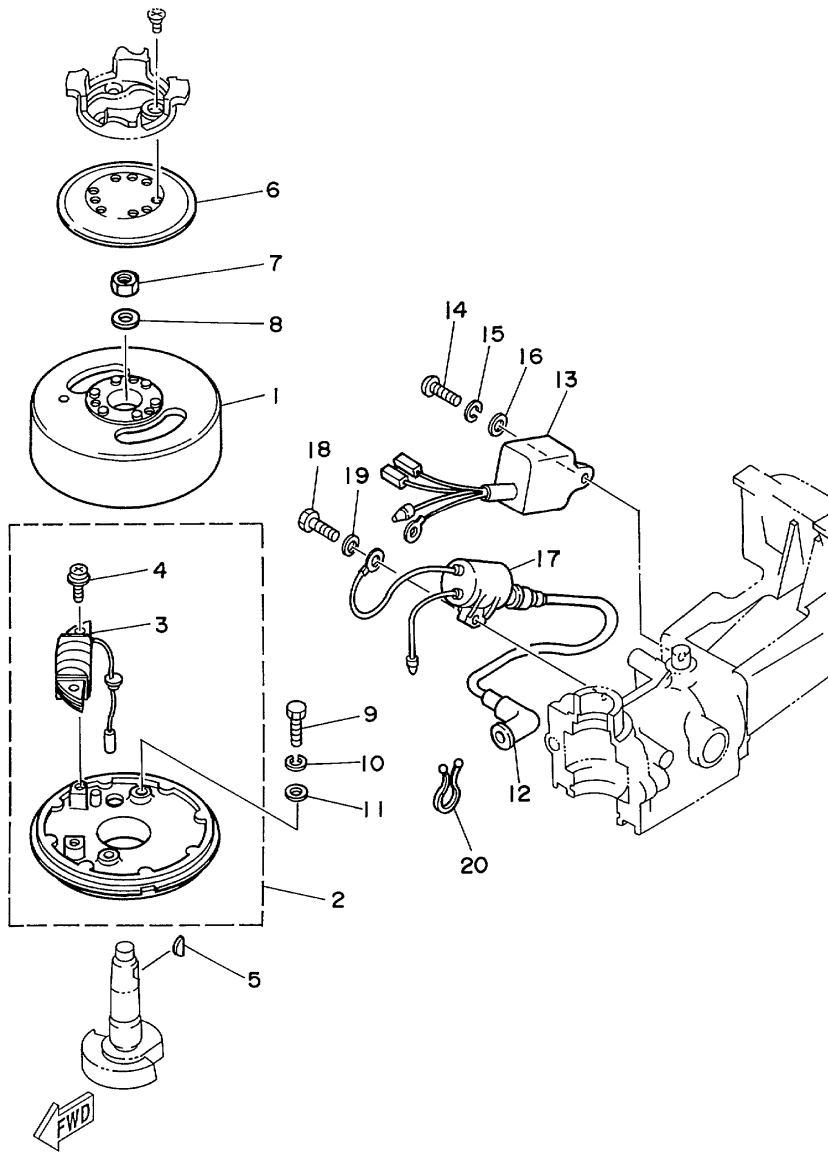

6A10010-5080

©2014 Yamaha Motor Corporation, U.S.A. All rights reserved.



## Part List

2MSHX 1999 / GENERATOR

REF - NO	PART NUMBER	PART NAME	QUANTITY	REMARKS
1	6A1-85550-00-00	ROTOR ASSY	1	
2	6A1-85560-00-00	BASE ASSY	1	
3	6A1-85520-00-00	.COIL, CHARGE	1	
4	97885-05020-00	.SCREW, PAN HEAD	2	
5	90280-04M06-00	KEY, WOODRUFF	1	
6	6A1-81362-00-00	COVER, HOLE	1	
7	90170-10M33-00	NUT	1	
8	92903-10100-00	WASHER, SPRING	1	
9	97013-06030-00	BOLT	2	
10	92903-06100-00	.WASHER, SPRING	2	
11	92903-06600-00	WASHER, PLATE	2	
12	663-82370-01-00	PLUG CAP ASSY	1	UR USA
13	6A1-85540-01-00	C.D.I. UNIT ASSY	1	
14	97885-06016-00	SCREW, PAN HEAD	1	
15	92995-06100-00	WASHER, SPRING	1	
16	92995-06600-00	WASHER	1	
17	6A1-85570-00-00	IGNITION COIL ASSY	1	
18	97095-06020-00	BOLT	1	
19	92995-06600-00	WASHER	1	
20	90464-08M07-00	CLAMP	1	

2MSHX 1999 / REPAIR KIT 1

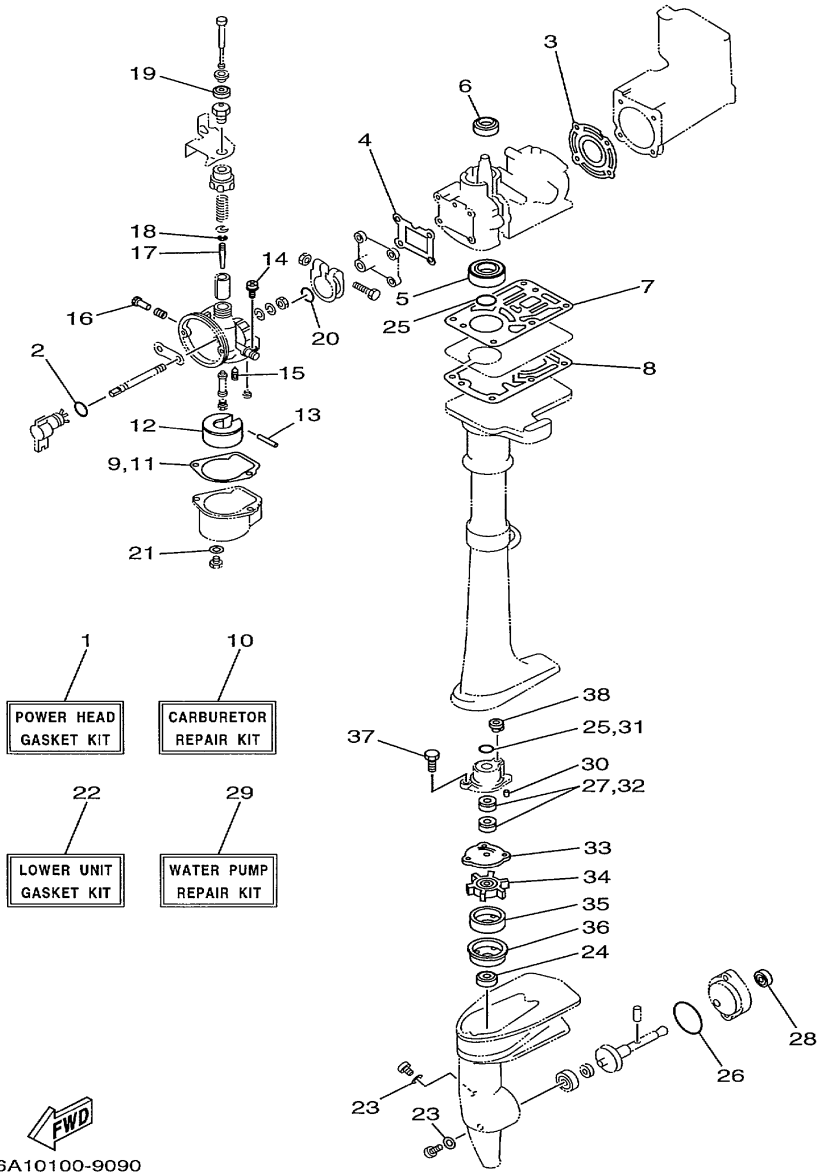

©2014 Yamaha Motor Corporation, U.S.A. All rights reserved.

## Part List

2MSHX 1999 / REPAIR KIT 1

REF - NO	PART NUMBER	PART NAME	QUANTITY	REMARKS
1	6A1-W0001-A2-00	POWER HEAD GASKET KIT	1	
2	93210-08M29-00	.O-RING	1	
3	6A1-11181-A1-00	.GASKET, CYLINDER HEAD 1	1	
4	6A1-13621-A0-00	.GASKET, VALVE SEAT	1	
5	93102-15M32-00	.OIL SEAL	1	
6	93102-20070-00	.OIL SEAL	1	
7	6A1-14613-A0-00	.GASKET, EXHAUST PIPE	1	
8	646-14623-A1-00	.GASKET, EXHAUST PIPE	1	
9	6A1-14384-00-00	.GASKET, FLOAT CHAMBER	1	
10	6A1-W0093-03-00	CARBURETOR REPAIR KIT	1	
11	6A1-14384-00-00	.GASKET, FLOAT CHAMBER	1	
12	6A1-14385-00-00	.FLOAT	1	
13	6A1-14386-00-00	.PIN, FLOAT	1	
14	97980-04110-00	.SCREW, WITH WASHER	2	
15	6A1-14392-00-00	.VALVE, NEEDLE	1	
16	646-14211-02-00	.SCREW, PILOT ADJUSTING	1	
17	6A1-14116-10-00	.NEEDLE	1	
18	646-14137-00-00	.CLIP	1	
19	646-14169-00-00	.CAP	1	
20	646-14229-01-00	.O-RING	1	
21	646-14198-01-00	.GASKET	1	
22	6A1-W0001-23-00	LOWER UNIT GASKET KIT	1	
23	90430-08020-00	.GASKET	2	
24	93103-11051-00	.OIL SEAL	1	
25	93210-19123-00	O-RING	2	
26	93210-42101-00	.O-RING	1	
27	93101-11M44-00	.OIL SEAL	2	
28	93103-10052-00	.OIL SEAL	1	
29	6A1-W0078-02-00	WATER PUMP REPAIR KIT	1	
30	93604-09068-00	.PIN, DOWEL	2	
31	93210-19123-00	O-RING	1	
32	93101-11M44-00	.OIL SEAL	2	
33	646-44323-00-00	.OUTER PLATE, CARTRIDGE	1	
34	646-44352-01-00	.IMPELLER	1	
35	646-44322-00-00	.INSERT, CARTRIDGE	1	
36	6A1-44325-00-00	.PROTECTOR, OIL SEAL	1	
37	97390-05016-00	.BOLT, HEXAGON	2	
38	6E0-44366-00-00	DAMPER, WATER SEAL 2	1	

## Part Notes

2MSHX 1999 / REPAIR KIT 1

PART NUMBER	NOTE TEXT
90430-08020-00 	OEM: This part number is among the Top 100 Most Popular Marine Maintenance Parts as of March 2014.

©2014 Yamaha Motor Corporation, U.S.A. All rights reserved.

©2014 Yamaha Motor Corporation, U.S.A. All rights reserved.