

F15CESH 0406 / TOP COWLING

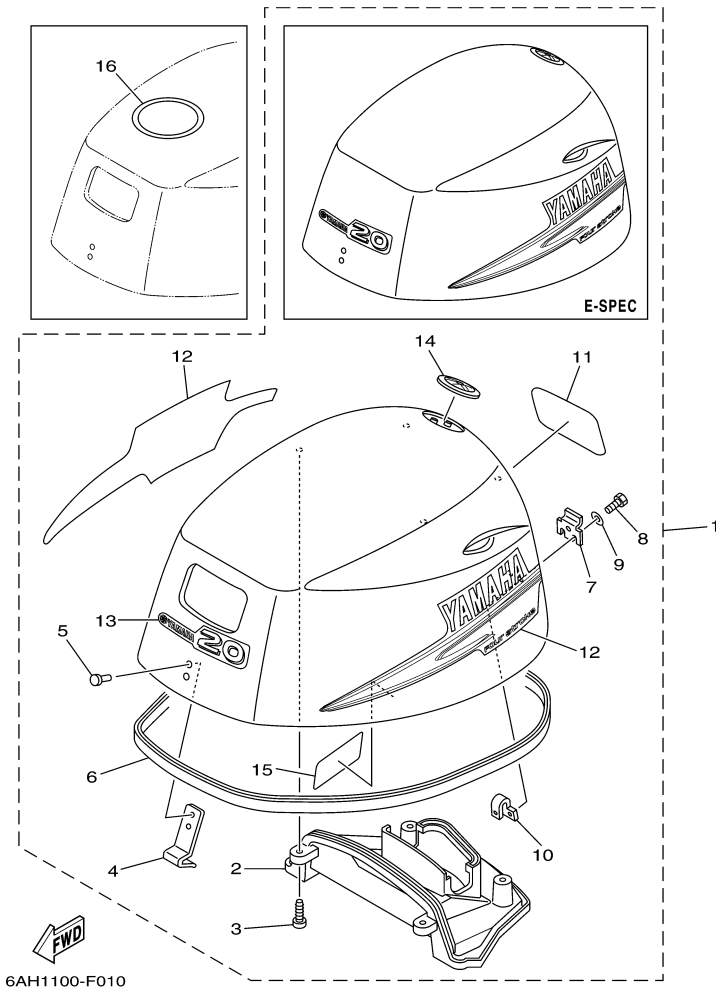

## Part List

F15CESH 0406 / TOP COWLING

REF - NO	PART NUMBER	PART NAME	QUANTITY	REMARKS
1	6AG-42610-10-4D	TOP COWLING ASSY	1	F15CEH/PH
1	6AG-42610-00-4D	TOP COWLING ASSY	1	F15CMH
2	6AH-42613-00-00	.MOLDING, AIR DUCT	1	
3	97780-50616-00	.SCREW, TAPPING	4	
4	6AH-42651-00-00	.HOOK	1	
5	90266-06M02-00	.RIVET	2	
6	6AH-42615-00-00	.SEAL	1	
7	60R-42652-00-00	.HOOK	1	
8	97095-05014-00	.BOLT	2	
9	92995-05600-00	.WASHER	2	
10	6AH-42649-00-00	.HOLDER, CLAMP BAND	1	
11	6AG-42678-00-00	.GRAPHIC, REAR	1	F15C
12	6AH-W0070-00-00	.GRAPHIC SET	1	
13	6AG-42677-00-00	.GRAPHIC, FRONT	1	F15C
14	6AH-42697-00-00	.TUNING FORK MARK	1	
15	6AH-42735-00-00	.PROTECTOR	1	
16	67F-13434-03-00	LABEL, CAUTION	1	

F15CESH 0406 / CYLINDER CRANKCASE 1

1  
CYLINDER BLOCK ASSY  
CYLINDER CRANKCASE 1, Ref. No. 2 to 23, 26 to 29  
CYLINDER CRANKCASE 2, Ref. No. 1 to 10  
INTAKE, Ref. No. 2  
OIL PUMP, Ref. No. 6 to 9  
GENERATOR, Ref. No. 7  
ELECTRICAL 1, Ref. No. 23, 30 to 33

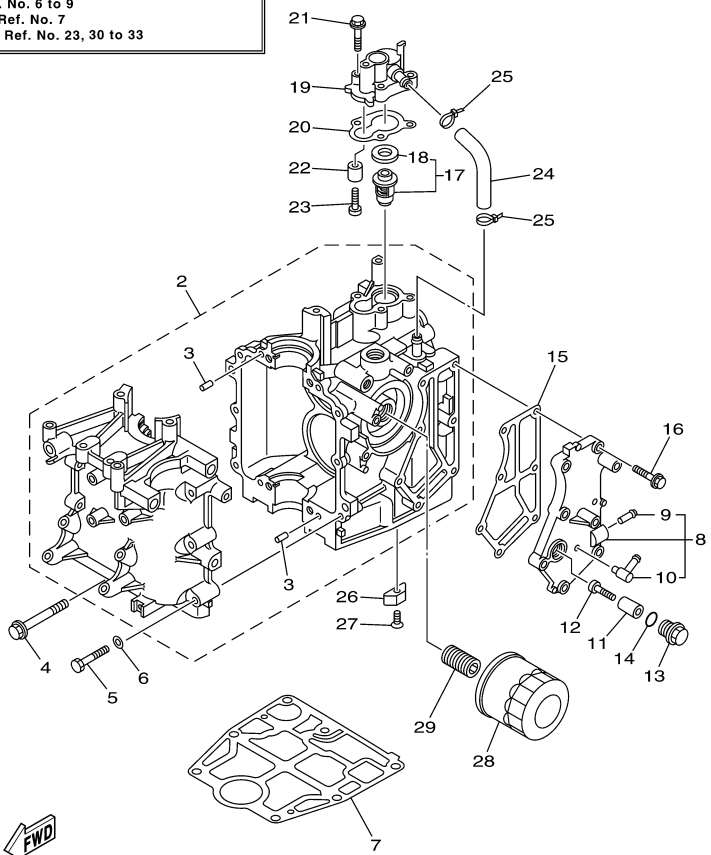

6AH1100-F020

## Part List

F15CESH 0406 / CYLINDER CRANKCASE 1

REF - NO	PART NUMBER	PART NAME	QUANTITY	REMARKS
1	6AH-W009B-00-1S	CYLINDER BLOCK ASSY	1	
2	6AH-15100-00-1S	CRANKCASE ASSY	1	
3	93606-12019-00	.PIN, DOWEL	4	
4	90119-08093-00	BOLT, WITH WASHER	4	
5	97013-06040-00	BOLT	6	
6	92903-06600-00	WASHER, PLATE	6	
7	6AH-11351-00-00	.GASKET, CYLINDER	1	
8	6AH-41113-00-1S	OUTER COVER, EXHAUST	1	
9	650-24378-00-00	.PIPE, JOINT 4	1	
10	676-11372-00-00	.NIPPLE, HOSE	1	
11	6G8-11325-00-00	ANODE	1	
12	97880-05025-00	SCREW, PAN HEAD	1	
13	6G8-11197-01-00	PLUG, BLIND	1	
14	93210-13M63-00	.O-RING	1	
15	6AH-41114-00-00	.GASKET, EXHAUST OUTER COVER	1	
16	90119-06MA3-00	BOLT, WITH WASHER	7	
17	6AH-12411-00-00	THERMOSTAT	1	
18	688-12412-00-00	.SEAL, THERMOSTAT	1	
19	6AH-12413-00-1S	COVER, THERMOSTAT	1	
20	6AH-12414-00-00	.GASKET, COVER	1	
21	90119-06MA3-00	BOLT, WITH WASHER	3	
22	6G8-11325-00-00	ANODE	1	
23	97880-05025-00	SCREW, PAN HEAD	1	
24	6AH-12481-00-00	PIPE 1	1	
25	90465-11M10-00	CLAMP	2	
26	6E5-11325-00-00	ANODE	1	
27	98780-04016-00	SCREW, FLAT HEAD	1	
28	5GH-13440-20-00	ELEMENT ASSY, OIL CLEANER	1	
29	6C5-12858-00-00	BOLT, UNION	1	

F15CESH 0406 / CRANKSHAFT PISTON

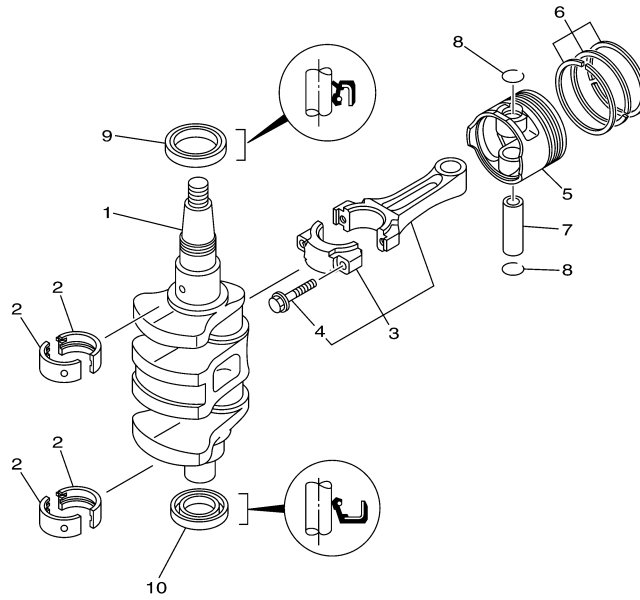

6AH1100-F030

## Part List

F15CESH 0406 / CRANKSHAFT PISTON

REF - NO	PART NUMBER	PART NAME	QUANTITY	REMARKS
1	6AH-11411-00-00	CRANKSHAFT	1	
2	6AH-11416-00-00	PLANE BEARING, CRANKSHAFT 1	4	UR BLUE
2	6AH-11416-20-00	PLANE BEARING, CRANKSHAFT 1	4	UR BROWN
2	6AH-11416-10-00	PLANE BEARING, CRANKSHAFT 1	4	UR BLACK
3	6AH-11650-00-00	CONNECTING ROD ASSY	2	
4	6AH-11654-00-00	.BOLT, CONNECTING ROD	2	
5	6AH-11631-00-00	PISTON (STD)	2	
5	6AH-11636-00-00	PISTON (0.50MM O/S)	2	AP
5	6AH-11635-00-00	PISTON (0.25MM O/S)	2	AP
6	6AH-11603-00-00	PISTON RING SET (STD)	2	
6	6AH-11605-00-00	PISTON RING SET (0.50MM O/S)	2	AP
6	6AH-11604-00-00	PISTON RING SET (0.25MM O/S)	2	AP
7	137-11633-10-00	PIN, PISTON	2	
8	93450-17129-00	CIRCLIP	4	
9	93102-37004-00	.OIL SEAL	1	
10	93102-25014-00	.OIL SEAL	1	

F15CESH 0406 / CYLINDER CRANKCASE 2

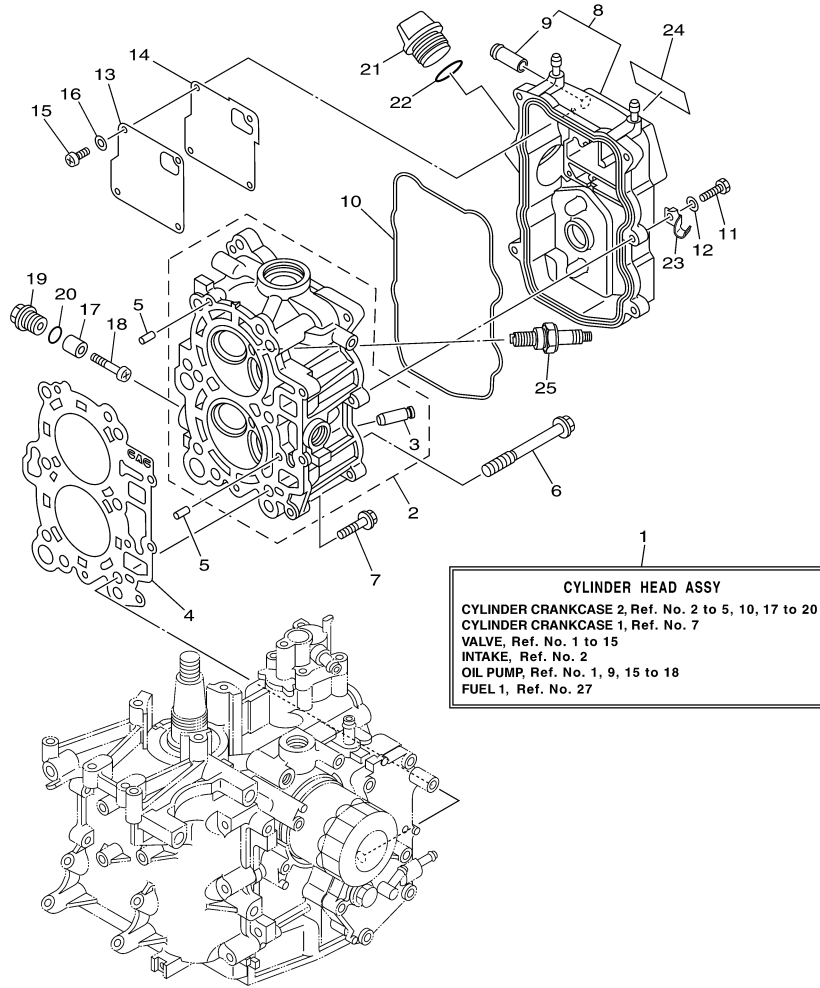

## Part List

F15CESH 0406 / CYLINDER CRANKCASE 2

REF - NO	PART NUMBER	PART NAME	QUANTITY	REMARKS
1	6AH-W009A-00-1S	CYLINDER HEAD COMPLETE	1	
2	6AH-11111-00-94	HEAD, CYLINDER 1	1	
3	6AH-11133-10-00	.GUIDE, VALVE 1	4	
4	6AH-11181-00-00	GASKET, CYLINDER HEAD 1	1	
5	93606-12019-00	.PIN, DOWEL	2	
6	90105-09006-00	BOLT, FLANGE	6	
7	90119-06MA3-00	BOLT, WITH WASHER	3	
8	6AH-11191-00-1S	COVER, CYLINDER HEAD 1	1	
9	6AH-11372-00-00	.NIPPLE, HOSE	1	
10	6AH-11356-00-00	.SEAL, CYLINDER 2	1	
11	97095-06020-00	BOLT	5	
12	92995-06600-00	WASHER	5	
13	6AH-11168-00-00	COVER, BREATHER	1	
14	6AH-11169-00-00	.GASKET, BREATHER COVER	1	
15	98507-04010-00	SCREW, PAN HEAD	4	
16	92907-04600-00	WASHER	4	
17	6G8-11325-00-00	ANODE	2	
18	97880-05025-00	SCREW, PAN HEAD	2	
19	6G8-11197-01-00	PLUG, BLIND	2	
20	93210-13M63-00	.O-RING	2	
21	6G8-15363-00-00	PLUG, OIL	1	
22	93210-24M79-00	.O-RING	1	
23	90465-08059-00	CLAMP	1	
24	62Y-12138-40-00	MARK, CAUTION	1	
25	NGK-DPR6E-B9-00	PLUG, SPARK (NGK DPR6EB)	2	



F15CESH 0406 / VALVE

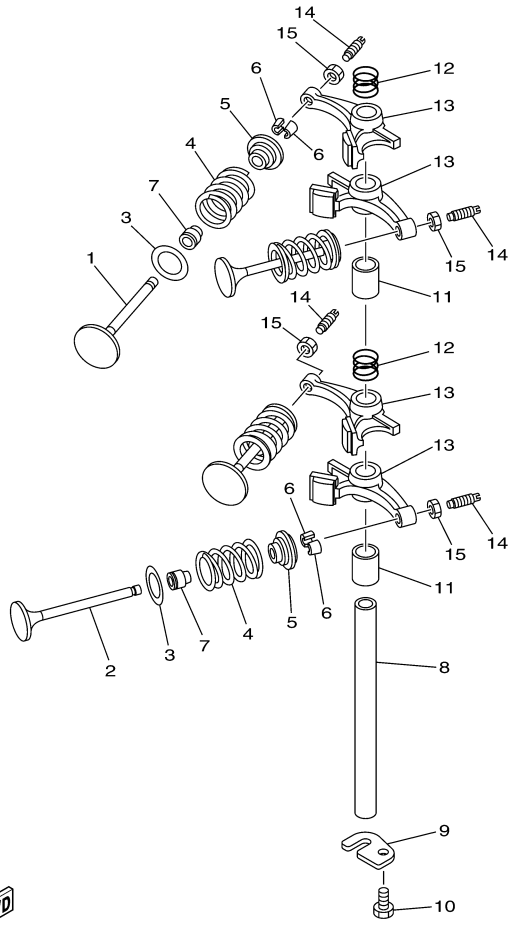

6AH1100-F050

## Part List

F15CESH 0406 / VALVE

REF - NO	PART NUMBER	PART NAME	QUANTITY	REMARKS
1	6AH-12111-00-00	VALVE, INTAKE	2	
2	6AH-12121-00-00	VALVE, EXHAUST	2	
3	62Y-12116-00-00	SEAT, VALVE SPRING	4	
4	3YF-12113-00-00	SPRING, VALVE INNER	4	
5	30X-12117-00-00	RETAINER, VALVE SPRING	4	
6	30X-12118-00-00	LOCK, VALVE SPRING RETAINER	8	
7	51Y-12119-00-00	SEAL, VALVE STEM	4	
8	66M-12146-00-00	SHAFT, ROCKER	1	
9	6AH-12279-00-00	PLATE	1	
10	97013-06012-00	BOLT	1	
11	90387-13006-00	COLLAR	2	
12	90501-120A5-00	SPRING, COMPRESSION	2	
13	6AH-12151-00-00	ARM, VALVE ROCKER	4	
14	64J-12159-00-00	SCREW, VALVE ADJUSTING	4	
15	62Y-12158-00-00	NUT, LOCK	4	

F15CESH 0406 / INTAKE

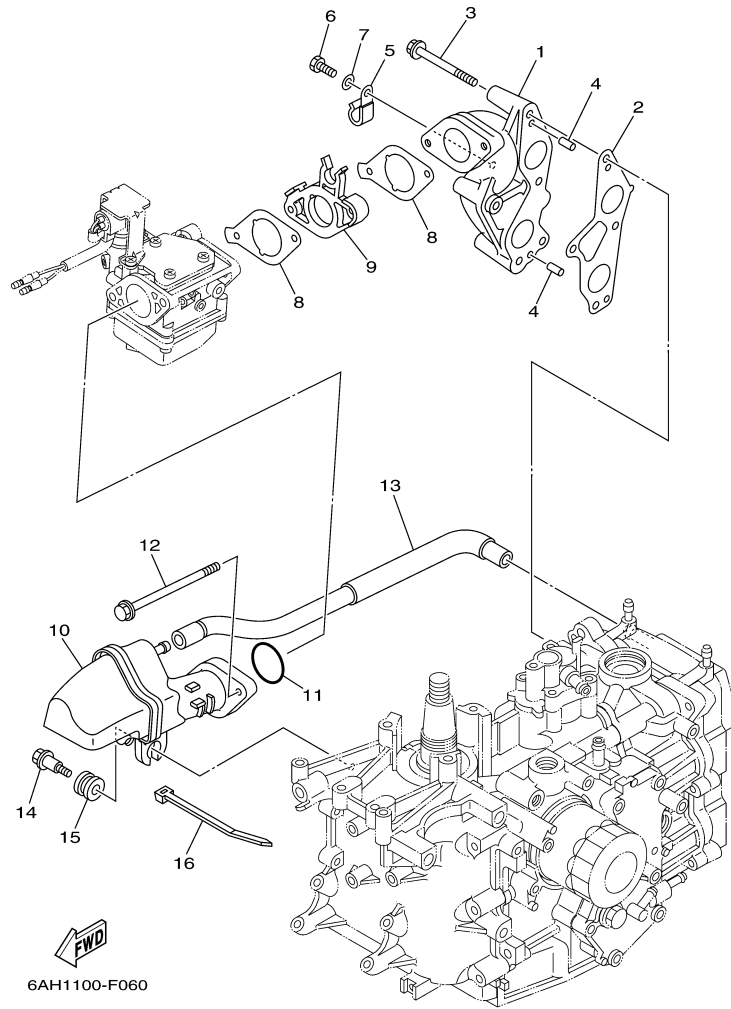

©2014 Yamaha Motor Corporation, U.S.A. All rights reserved.

## Part List

F15CESH 0406 / INTAKE

REF - NO	PART NUMBER	PART NAME	QUANTITY	REMARKS
1	6AH-13641-00-94	MANIFOLD, INTAKE 1	1	
2	6AH-13645-00-00	.GASKET, MANIFOLD 1	1	
3	97595-06555-00	BOLT, WITH WASHER	4	
4	91690-50014-00	PIN, SPRING	2	
5	90465-08M83-00	CLAMP	2	
6	97095-06012-00	BOLT	2	
7	92995-06600-00	WASHER	2	
8	6AH-13646-00-00	.GASKET, MANIFOLD 2	2	
9	6AH-14271-00-00	INSULATOR	1	
10	6AH-14440-00-00	SILENCER ASSY, INTAKE	1	
11	93210-35M86-00	.O-RING	1	
12	95895-06100-00	BOLT, FLANGE	2	
13	6AH-15373-00-00	PIPE, BREATHER	1	
14	90109-06MA1-00	BOLT	1	
15	90480-16616-00	GROMMET	1	
16	90465-13M18-00	CLAMP	1	

F15CESH 0406 / CARBURETOR

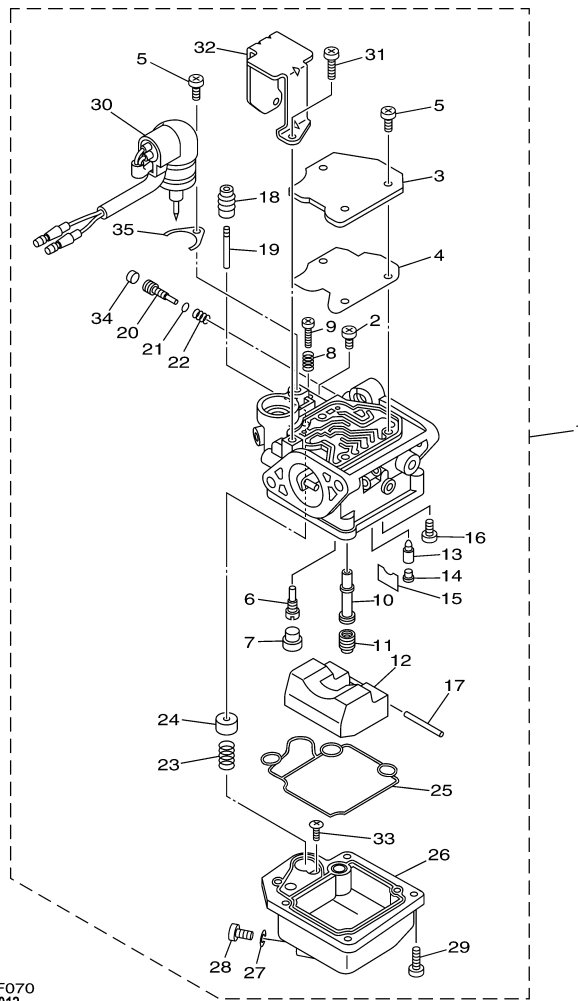

  
6AH1100-F070  
Rev. 3-20-2012



## Part List

F15CESH 0406 / CARBURETOR

REF - NO	PART NUMBER	PART NAME	QUANTITY	REMARKS
1	6AG-14301-40-00	CARBURETOR ASSY 1	1	F15CEH/PH
1	6AG-14301-00-00	CARBURETOR ASSY 1	1	F15CMH
2	98580-04006-00	.SCREW, PAN HEAD	1	
3	65W-14572-00-00	.PLATE	1	
4	65W-14126-10-00	.GASKET	1	
5	97980-04110-00	.SCREW, WITH WASHER	4	
6	6AG-14948-05-00	.JET (#45)	1	FOR 6AH-14301-00
6	6AH-14948-02-00	.JET (#38)	1	FOR 6AG-14301-40
6	676-14948-05-00	.JET (#45)	1	FOR 6AH-14301-40
6	6AG-14948-02-00	.JET (#38)	1	FOR 6AG-14301-00
7	679-14966-00-00	.RUBBER CAP	1	
8	90501-10326-00	.SPRING, COMPRESSION	1	
9	63V-14523-00-00	.SCREW, STOP	1	
10	6AH-14947-10-00	.JET, NEEDLE	1	F15C
11	676-14943-19-00	.JET, MAIN (#80)	1	F15C
12	6AH-14985-00-00	.FLOAT	1	
13	6G1-14546-01-00	.VALVE, NEEDLE	1	
14	676-14186-00-00	.PIN, FLOAT	1	
15	663-14159-00-00	.CLIP	1	
16	98580-04008-00	.SCREW, PAN HEAD	1	
17	6H4-14548-00-00	.PIN, FLOAT ARM	1	
18	65W-14373-01-00	.COVER, PLUNGER CAP	1	
19	6AH-14379-00-00	.ROD, STARTER	1	
20	6AH-14923-00-00	.SCREW, PILOT	1	
21	67C-14397-00-00	.O-RING	1	
22	67C-14555-00-00	.SPRING	1	
23	65W-14335-00-00	.SPRING, PLUNGER	1	F15C
24	6AH-14371-00-00	.PLUNGER, STARTER	1	
25	6AH-14384-00-00	.GASKET, FLOAT CHAMBER	1	
26	6AH-14980-00-00	.BODY, FLOAT CHAMBER	1	
27	65W-14398-00-00	.GASKET	1	
28	65W-14992-00-00	.SCREW, DRAIN	1	
29	97980-04114-00	.SCREW, WITH WASHER	4	
30	6AH-14380-10-00	.PRIME STARTER ASSY	1	E-SPEC
30	6AH-14380-00-00	.PRIME STARTER ASSY	1	M-SPEC
31	97980-04108-00	.SCREW, WITH WASHER	2	
32	6AH-14346-00-00	.PLATE	1	
33	67C-14567-00-00	.SCREW	1	
34	67C-1432A-00-00	.PLUG	1	
35	65W-14346-00-00	.PLATE	1	

## Part Notes

F15CESH 0406 / CARBURETOR

PART NUMBER	NOTE TEXT
6AH-14380-10-00	 OEM: The O-Ring for sealing this part to the carburetor body is not shown separately. The Part Number for the O-Ring is 93210-17001-00.
6AH-14380-00-00	 OEM: The O-Ring for sealing this part to the carburetor body is not shown separately. The Part Number for the O-Ring is 93210-17001-00.

©2014 Yamaha Motor Corporation, U.S.A. All rights reserved.

F15CESH 0406 / OIL PUMP

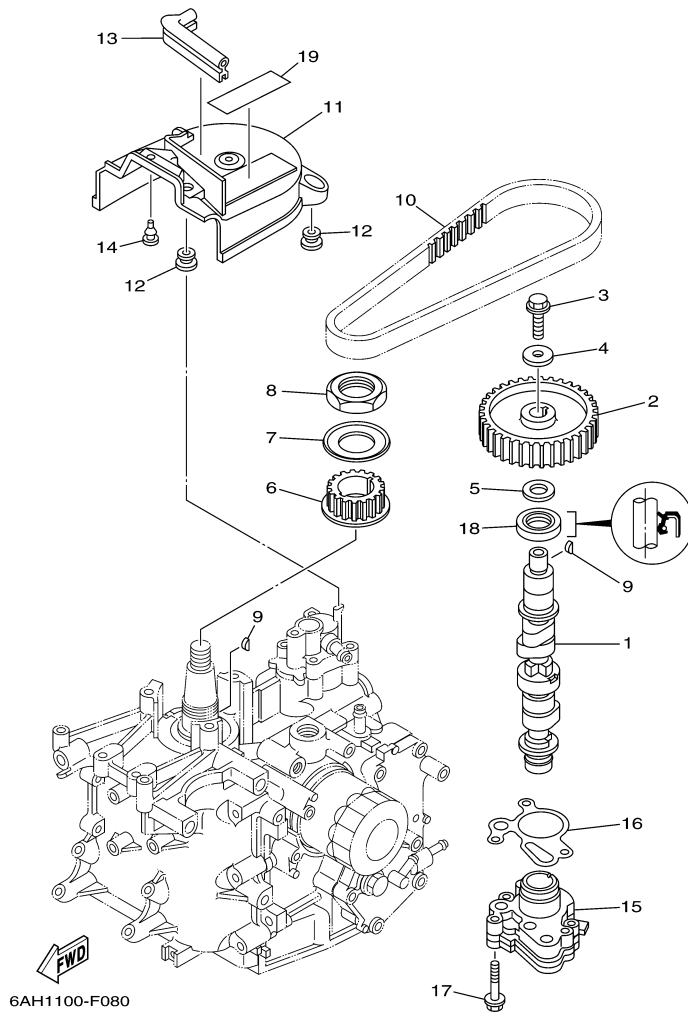

6AH1100-F080

## Part List

F15CESH 0406 / OIL PUMP

REF - NO	PART NUMBER	PART NAME	QUANTITY	REMARKS
1	6AH-12170-00-00	CAMSHAFT ASSY 1	1	
2	6AH-11537-00-94	GEAR, DRIVEN	1	
3	90105-081A7-00	BOLT, FLANGE	1	
4	90201-08784-00	WASHER, PLATE	1	
5	90201-15423-00	WASHER, PLATE	1	
6	6AH-11536-00-00	GEAR, DRIVE	1	
7	6AH-11557-00-00	WASHER 1	1	
8	90170-30003-00	NUT	1	
9	90280-03M01-00	.KEY, WOODRUFF	2	
10	6AH-46241-00-00	BELT	1	
11	6AH-46297-00-00	COVER, DUST	1	
12	90480-10627-00	GROMMET	3	
13	6AH-42617-00-00	DAMPER, FORM	1	
14	90480-06M19-00	GROMMET	1	
15	6AH-13300-00-00	OIL PUMP ASSY	1	
16	6AH-13329-00-00	.GASKET, PUMP COVER	1	
17	90105-06035-00	BOLT, FLANGE	3	
18	93102-22009-00	.OIL SEAL	1	
19	6AH-13437-40-00	MARK, CAUTION	1	



F15CESH 0406 / FUEL 1

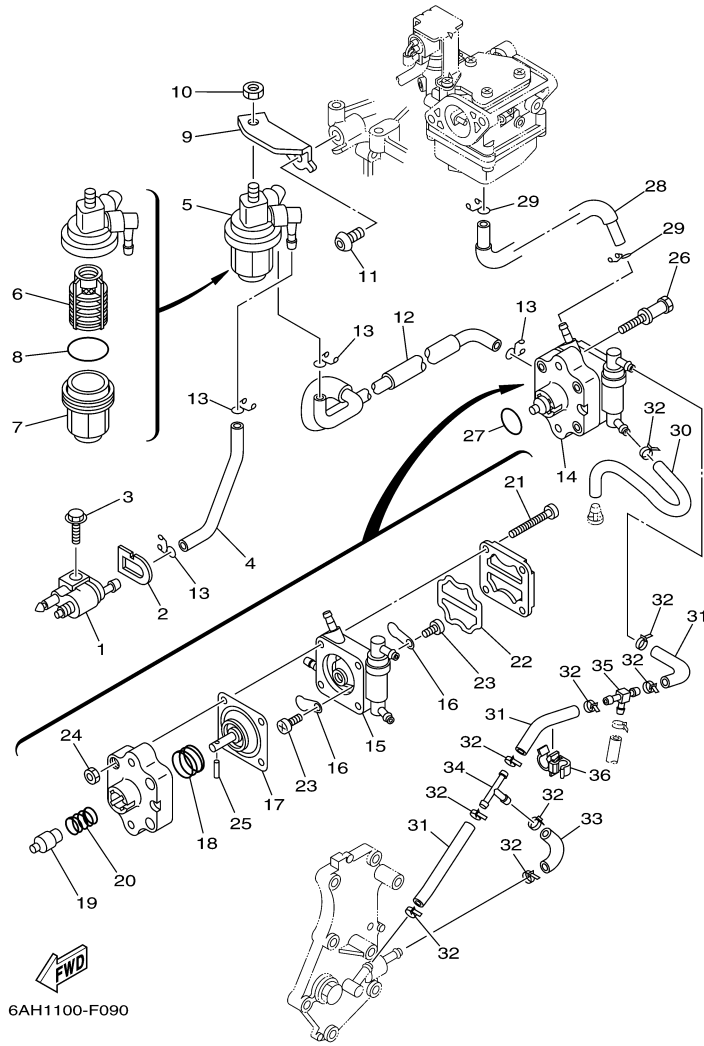

©2014 Yamaha Motor Corporation, U.S.A. All rights reserved.

## Part List

F15CESH 0406 / FUEL 1

REF - NO	PART NUMBER	PART NAME	QUANTITY	REMARKS
1	6G1-24304-02-00	FUEL PIPE JOINT COMP. 1	1	
2	61N-24329-00-00	SEAL	1	
3	95895-06020-00	BOLT, FLANGE	1	
4	6AH-24311-00-00	PIPE, FUEL 1	1	
5	61N-24560-00-00	FILTER ASSY	1	
6	61N-24563-00-00	.ELEMENT, FILTER	1	
7	61N-24521-00-00	.CUP, FILTER	1	
8	93210-32738-00	.O-RING	1	
9	6AH-24566-00-00	BRACKET, FILTER	1	
10	95380-08600-00	NUT	1	
11	90111-08055-00	BOLT,HEX. SOCKET BUTTON	1	
12	6AH-24312-00-00	PIPE 2	1	
13	90467-09M17-00	CLIP	4	
14	6AH-24410-00-00	FUEL PUMP ASSY	1	
15	6AH-24413-00-00	.BODY 2	1	
16	6A0-24421-01-00	.VALVE, CHECK	2	
17	66M-24411-11-00	.DIAPHRAGM	1	
18	66M-24423-00-00	.SPRING, DIAPHRAGM	1	
19	66M-13131-10-00	.PLUNGER	1	
20	66M-24454-00-00	.SPRING	1	
21	66M-24444-00-00	.SCREW	4	
22	66M-24471-01-00	.DIAPHRAGM	1	
23	6E7-14325-00-00	.SCREW, PAN HEAD	2	
24	95380-04600-00	.NUT	4	
25	66M-24374-00-00	.PIN	1	
26	90109-06215-00	BOLT	2	
27	93210-20M65-00	.O-RING	1	
28	6AH-24313-00-00	PIPE 3	1	
29	90467-09M17-00	CLIP	2	
30	6AH-24315-00-00	PIPE 5	1	
31	90445-09026-00	HOSE (L68)	3	
32	90465-11M10-00	CLAMP	9	
33	6AH-24317-00-00	PIPE 7	1	
34	688-24378-00-00	PIPE, JOINT 3	1	
35	6C5-24378-00-00	PIPE, JOINT 3	1	
36	90464-09018-00	CLAMP	1	



## Part List

F15CESH 0406 / FUEL 2

REF - NO	PART NUMBER	PART NAME	QUANTITY	REMARKS
1	6Y2-24306-56-00	FUEL PIPE COMP. 1	1	AP
2	6E5-24305-06-00	.FUEL PIPE JOINT COMP 2	1	
3	93210-08287-00	..O-RING	1	
4	6Y2-24305-06-00	.FUEL PIPE JOINT COMP 2	1	
5	93210-08287-00	..O-RING	1	
6	90445-13M01-00	.HOSE (L2050)	1	
7	6E5-24351-51-00	.BAND 1	4	
8	90445-13M00-00	.HOSE (L850)	1	
9	6Y2-24360-60-00	.PRIMER PUMP ASSY	1	

F15CESH 0406 / STARTER

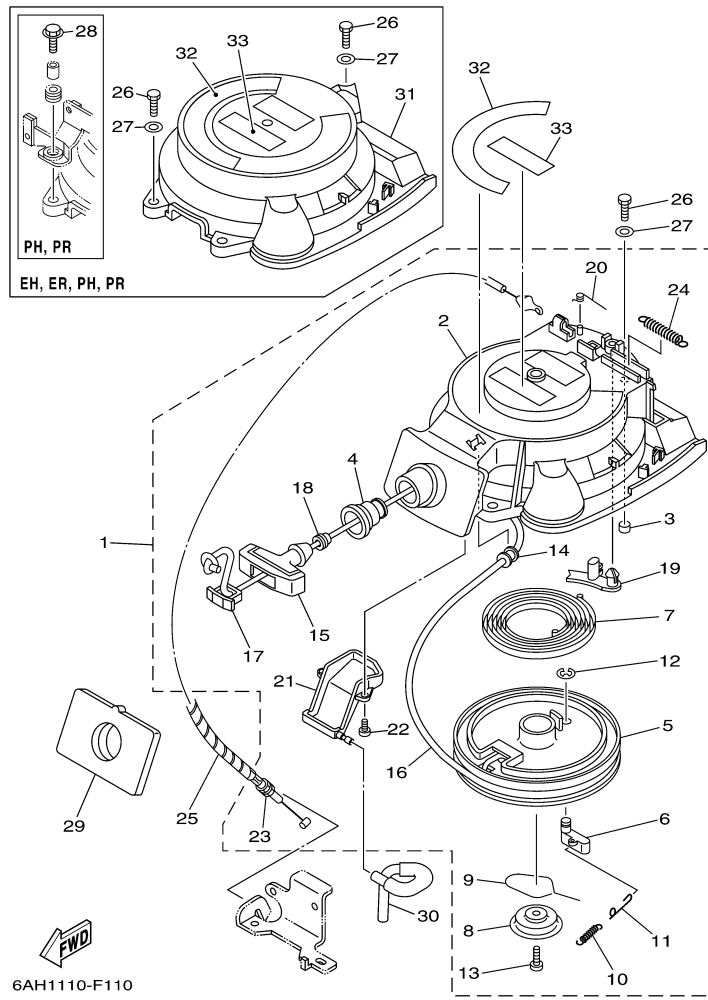

©2014 Yamaha Motor Corporation, U.S.A. All rights reserved.

## Part List

F15CESH 0406 / STARTER

REF - NO	PART NUMBER	PART NAME	QUANTITY	REMARKS
1	6AH-15710-00-00	STARTER ASSY	1	MH
2	6AH-15711-00-00	.CASE, STARTER	1	
3	67D-15764-00-00	.COLLAR 1	3	
4	6AH-15795-00-00	.GUIDE, ROPE	1	
5	63V-15714-00-00	.DRUM, SHEAVE	1	
6	63V-15741-00-00	.PAWL, DRIVE	1	
7	63V-15713-00-00	.SPRING, STARTER	1	
8	68T-15716-00-00	.PLATE, DRIVE	1	
9	63V-15705-01-00	.SPRING, DRIVE PAWL	1	
10	63V-15767-01-00	.SPRING	1	
11	68T-15784-00-00	.SPRING, RETURN	1	
12	63V-15744-00-00	.CIRCLIP	1	
13	68T-15793-00-00	.SCREW	1	
14	68T-15764-00-00	.COLLAR 1	1	
15	689-15755-01-00	.HANDLE, STARTER	1	
16	90890-44373-00	ROPE, STARTER	1	UNAVAILABLE, CUT TO 1.8M
17	6F5-15779-02-00	.COVER	1	
18	6A0-15789-00-00	.DAMPER	1	
19	66T-15794-00-00	.STOPPER	1	
20	66T-15734-00-00	.SPRING, RETURN	1	
21	6AH-15782-00-00	.COVER, SHEAVE	1	
22	6AH-15793-00-00	.SCREW	2	
23	6AH-15770-00-00	.CABLE COMP, STARTER STOP	1	
24	66T-15731-00-00	.SPRING, RETURN	1	
25	90446-06M90-00	HOSE (L120)	1	MH
26	97095-06020-00	BOLT	3	MH/EH/ER
26	97095-06020-00	BOLT	1	PH/PR
27	92995-06600-00	WASHER	3	MH/EH/ER
27	92995-06600-00	WASHER	1	PH/PR
28	90119-06169-00	BOLT, WITH WASHER	2	PH/PR
29	6AH-15762-00-00	SEAL, RUBBER 2	1	MH
30	6AH-24316-00-00	PIPE 6	1	MH
31	6AH-81337-00-00	COVER, FLYWHEEL	1	EH/ER/PH/PR
32	6AH-14427-40-00	LABEL, INSTRUCTION	1	
33	6A1-83625-41-00	MARK 5	1	

F15CESH 0406 / GENERATOR

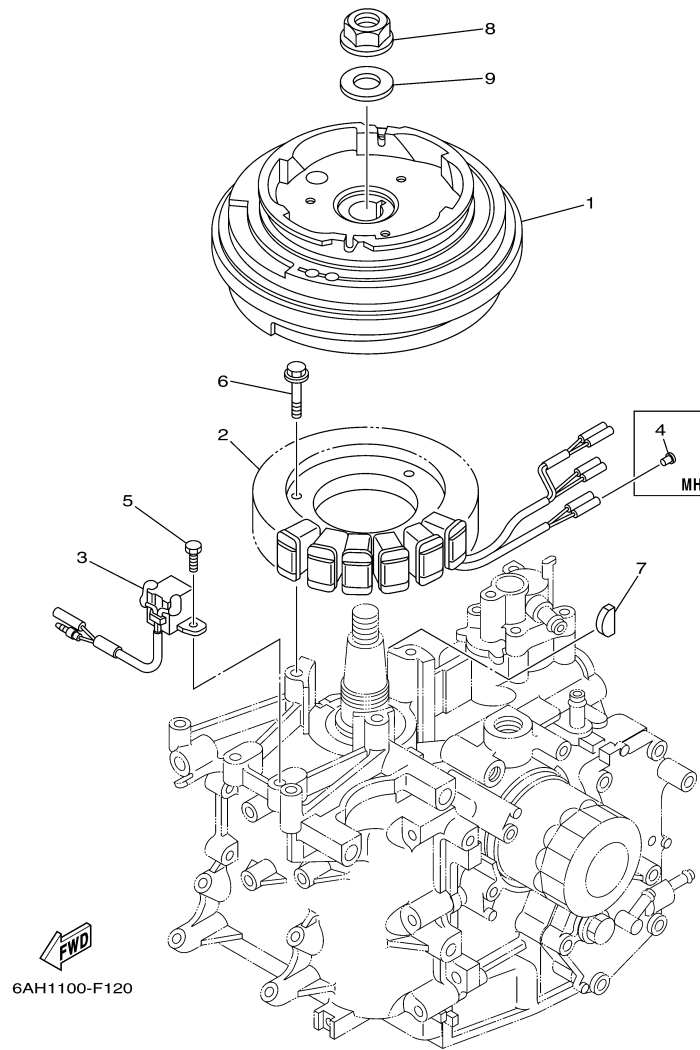

©2014 Yamaha Motor Corporation, U.S.A. All rights reserved.

## Part List

F15CESH 0406 / GENERATOR

REF - NO	PART NUMBER	PART NAME	QUANTITY	REMARKS
1	6AH-85550-10-00	ROTOR ASSY	1	EH/ER/PH/PR
1	6AH-85550-00-00	ROTOR ASSY	1	MH
2	6AH-85510-00-00	STATOR ASSY	1	
3	6AH-85580-00-00	COIL, PULSER	1	
4	703-82119-00-00	COVER, LEAD WIRE	2	MH
5	97095-05012-00	BOLT	2	
6	95895-06030-00	BOLT, FLANGE	3	
7	90280-05013-00	KEY, WOODRUFF	1	
8	90179-16M05-00	NUT	1	
9	90201-16M44-00	WASHER, PLATE	1	



F15CESH 0406 / ELECTRICAL 1

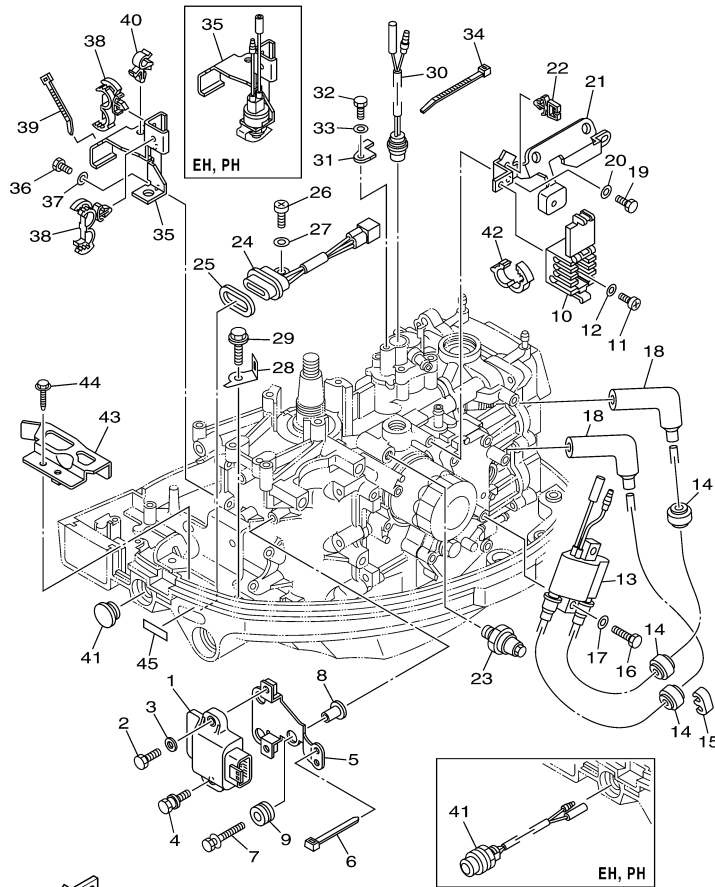

6AH1110-F130

## Part List

F15CESH 0406 / ELECTRICAL 1

REF - NO	PART NUMBER	PART NAME	QUANTITY	REMARKS
1	6AH-85540-00-00	C.D.I. UNIT ASSY	1	
2	97095-06020-00	BOLT	1	
3	92995-06600-00	WASHER	1	
4	90109-06221-00	BOLT	1	
5	6AH-81948-00-00	BRACKET	1	
6	90465-13M18-00	CLAMP	1	
7	90119-06M35-00	BOLT, WITH WASHER	3	
8	90387-06M60-00	COLLAR	3	
9	90480-10M23-00	GROMMET	3	
10	6AH-82522-00-00	CLAMP, COUPLER	1	
11	97880-06010-00	SCREW, PAN HEAD	1	
12	90201-06M05-00	WASHER, PLATE	1	
13	6F5-85570-12-00	IGNITION COIL ASSY	1	
14	90480-25003-00	GROMMET	3	
15	67F-82361-00-00	CLAMP, CORD	1	
16	97095-06025-00	BOLT	2	
17	92995-06600-00	WASHER	2	
18	6AH-82370-00-00	PLUG CAP ASSY	2	
19	97095-06014-00	BOLT	2	
20	92995-06600-00	WASHER	2	
21	6AH-85542-00-00	BRACKET	1	
22	90464-07M56-00	CLAMP	2	
23	64J-82504-00-00	OIL PRESSURE SWITCH ASSY	1	
24	62Y-84301-00-00	PILOT LIGHT ASSY 1	1	
25	6H4-83589-00-00	GASKET	1	
26	97885-06012-00	SCREW, PAN HEAD	1	
27	92995-06600-00	WASHER	1	
28	6AH-82388-00-00	PLATE	1	MH/EH/ER
29	90109-06M86-00	BOLT	1	MH/EH/ER
30	6AH-82560-00-00	THERMO SWITCH ASSY	1	
31	6AH-82588-00-00	PLATE	1	
32	97095-06014-00	BOLT	1	
33	92995-06600-00	WASHER	1	
34	90465-11M10-00	CLAMP	1	
35	6AH-82540-00-00	NEUTRAL SWITCH ASSY	1	EH/PH
35	6AH-82554-00-00	STAY, NEUTRAL SWITCH	1	MH/ER/PR
36	97095-06016-00	BOLT	2	
37	92995-06600-00	WASHER	2	
38	90464-18246-00	CLAMP	2	
39	90465-13M18-00	CLAMP	1	
40	90464-10M32-00	CLAMP	1	
41	68T-81870-00-00	STARTING SWITCH ASSY	1	EH/PH
41	6G1-42725-00-00	GROMMET	1	MH/ER/PR
42	90464-16003-00	CLAMP	1	MH/EH/PH
42	90464-16001-00	CLAMP	1	ER/PR
43	6AH-82389-00-00	PLATE 2	1	
44	90109-06M86-00	BOLT	1	
45	67C-85415-00-00	MARK, SIGNAL LAMP	1	

F15CESH 0406 / ELECTRICAL 2

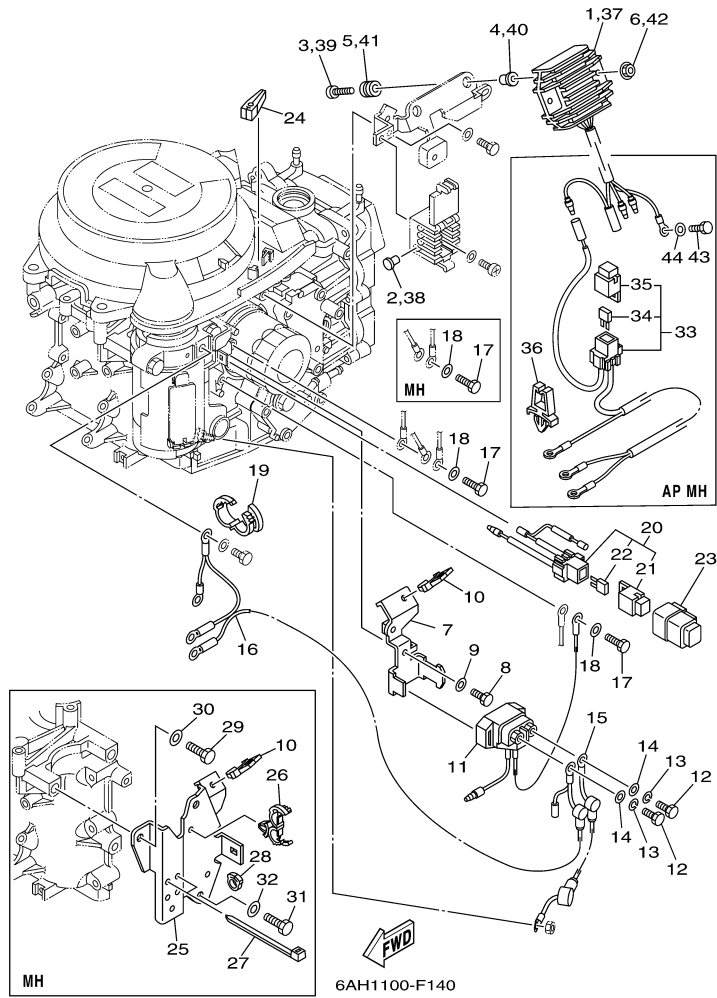

©2014 Yamaha Motor Corporation, U.S.A. All rights reserved.

## Part List

F15CESH 0406 / ELECTRICAL 2

REF - NO	PART NUMBER	PART NAME	QUANTITY	REMARKS
1	6AH-81960-00-00	RECTIFIER & REGULATOR ASSY	1	EH/ER/PH/PR
2	703-82119-00-00	COVER, LEAD WIRE	1	EH/ER/PH/PR
3	98980-06030-00	SCREW, BIND	2	EH/ER/PH/PR
4	90387-06M70-00	COLLAR	2	EH/ER/PH/PR
5	90480-13M24-00	GROMMET	2	EH/ER/PH/PR
6	95780-06500-00	NUT, FLANGE	2	EH/ER/PH/PR
7	6AH-81945-00-00	PLATE, SWITCH FITTING	1	EH/ER/PH/PR
8	97095-06014-00	BOLT	1	EH/ER/PH/PR
9	92995-06600-00	WASHER	1	EH/ER/PH/PR
10	90464-08004-00	CLAMP	1	
11	68T-81940-00-00	STARTER RELAY ASSY	1	EH/ER/PH/PR
12	97095-06010-00	BOLT	2	EH/ER/PH/PR
13	92995-06100-00	WASHER, SPRING	2	EH/ER/PH/PR
14	92995-06600-00	WASHER	2	EH/ER/PH/PR
15	6AH-82117-00-00	WIRE, LEAD	1	EH/ER/PH/PR
16	6AH-82105-00-00	BATTERY CABLE	1	EH/ER/PH/PR
17	97095-06014-00	BOLT	2	EH/ER/PH/PR
17	97095-06014-00	BOLT	1	MH
18	92995-06600-00	WASHER	2	EH/ER/PH/PR
18	92995-06600-00	WASHER	1	MH
19	90464-16001-00	CLAMP	1	EH/ER/PH/PR
20	6AH-82150-00-00	FUSE HOLDER ASSY	1	EH/ER/PH/PR
21	67F-8215B-10-00	.CAP (YELLOW)	1	
22	67F-82151-00-00	.FUSE (20A)	2	
23	6AH-82157-00-00	DAMPER	1	EH/ER/PH/PR
24	67F-2812A-00-00	.PULLER, FUSE	1	EH/ER/PH/PR
25	6AH-82398-00-00	PLATE 3	1	MH
26	90464-18246-00	CLAMP	1	MH
27	90465-13M18-00	CLAMP	3	MH
28	90464-09010-00	CLAMP	1	MH
29	97095-08025-00	BOLT	2	MH
30	92995-08600-00	WASHER	2	MH
31	97095-08016-00	BOLT	1	MH
32	92995-08600-00	WASHER	1	MH
33	6AH-81949-00-00	WIRE, LEAD	1	AP MH
34	67F-82151-00-00	.FUSE (20A)	2	
35	67F-8215B-00-00	.CAP (BLACK)	1	
36	90464-06001-00	CLAMP	1	AP MH
37	6AH-81960-00-00	RECTIFIER & REGULATOR ASSY	1	AP MH
38	703-82119-00-00	COVER, LEAD WIRE	1	AP MH
39	98980-06030-00	SCREW, BIND	2	AP MH
40	90387-06M70-00	COLLAR	2	AP MH
41	90480-13M24-00	GROMMET	2	AP MH
42	95780-06500-00	NUT, FLANGE	2	AP MH
43	97095-06014-00	BOLT	1	AP MH
44	92995-06600-00	WASHER	1	AP MH

F15CESH 0406 / ELECTRICAL 3

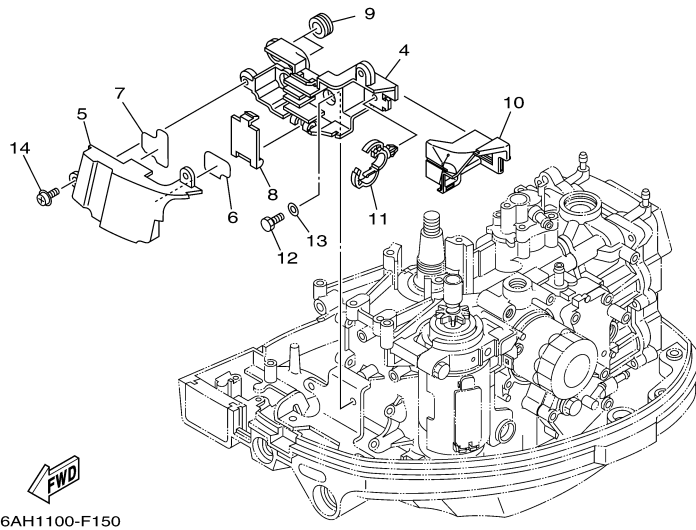
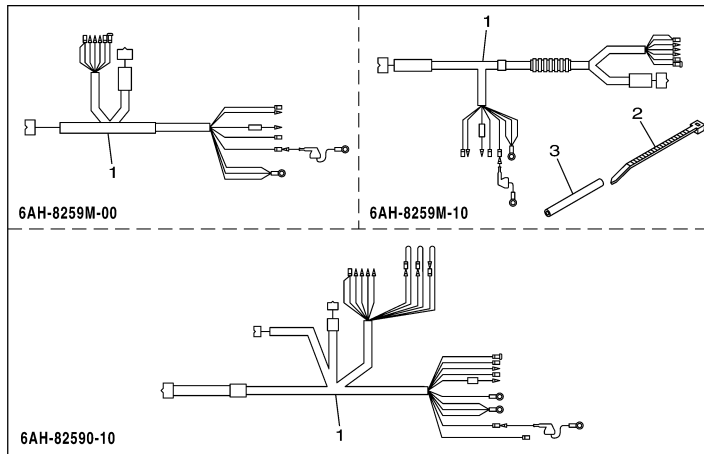

6AH1100-F150

## Part List

F15CESH 0406 / ELECTRICAL 3

REF - NO	PART NUMBER	PART NAME	QUANTITY	REMARKS
1	6AH-8259M-10-00	WIRE HARNESS ASSY 2	1	MH
1	6AH-82590-10-00	WIRE HARNESS ASSY	1	ER
1	6AH-8259M-00-00	WIRE HARNESS ASSY 2	1	EH
2	90465-13M18-00	CLAMP	1	MH
3	90445-08029-00	HOSE	1	MH
4	6AH-8552A-00-00	HOUSING	1	MH/EH/ER
5	6AH-8552E-00-00	COVER, CASE	1	MH/EH/ER
6	6AH-42735-30-00	PROTECTOR	1	MH/EH/ER
7	6AH-42735-40-00	PROTECTOR	1	MH/EH/ER
8	6AH-85537-00-00	COVER	1	MH/EH/ER
9	90480-19368-00	GROMMET	2	MH/EH/ER
10	6AH-85547-00-00	DAMPER	1	MH/EH/ER
11	90464-20181-00	CLAMP	1	MH/EH/ER
12	97095-06014-00	BOLT	2	MH/EH/ER
13	92995-06600-00	WASHER	2	MH/EH/ER
14	97985-06214-00	SCREW, WITH WASHER	2	MH/EH/ER

F15CESH 0406 / ELECTRICAL 4

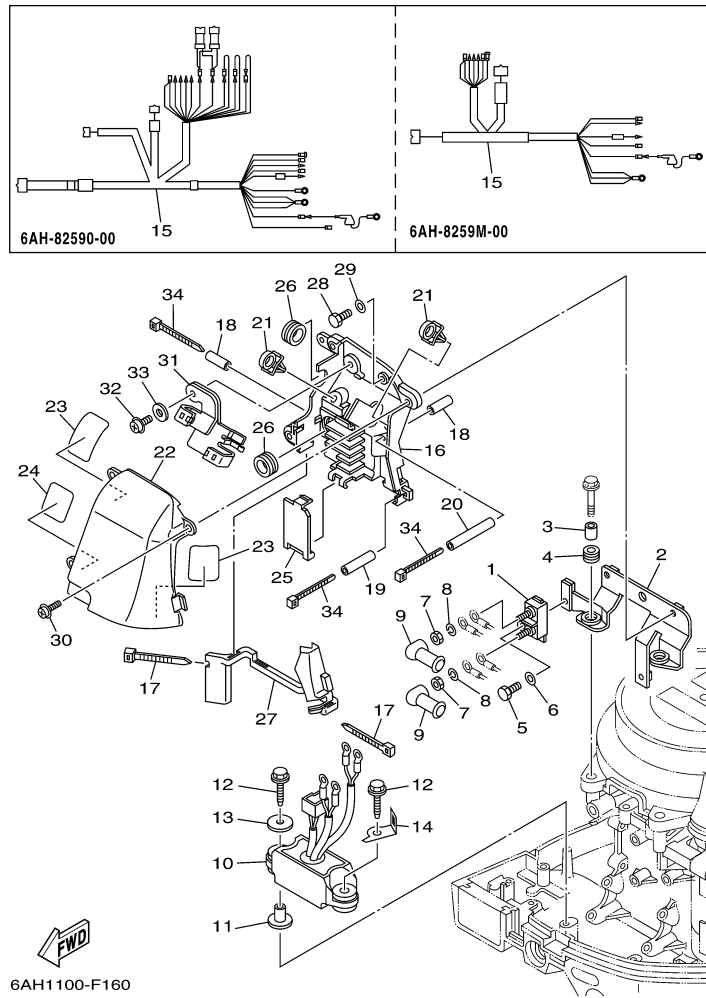

## Part List

F15CESH 0406 / ELECTRICAL 4

REF - NO	PART NUMBER	PART NAME	QUANTITY	REMARKS
1	6H5-81925-00-00	TERMINAL	1	PH/PR
2	6AH-81929-00-00	BRACKET, TERMINAL	1	PH/PR
3	90387-06182-00	COLLAR	2	PH/PR
4	6AH-82317-00-00	DAMPER, IGNITION COIL	2	PH/PR
5	97095-06014-00	BOLT	1	PH/PR
6	92995-06600-00	WASHER	1	PH/PR
7	90170-06M30-00	NUT	2	PH/PR
8	90204-06M00-00	WASHER, SPRING	2	PH/PR
9	6G5-82119-00-00	COVER, LEAD WIRE	2	PH/PR
10	6AH-81950-00-00	RELAY ASSY	1	PH/PR
11	90387-06M03-00	COLLAR	2	PH/PR
12	90109-06MA2-00	BOLT	2	PH/PR
13	90201-06416-00	WASHER, PLATE	1	PH/PR
14	6AH-82388-00-00	PLATE	1	PH/PR
15	6AH-82590-00-00	WIRE HARNESS ASSY	1	PR
15	6AH-8259M-00-00	WIRE HARNESS ASSY 2	1	PH
16	6AH-8552A-10-00	HOUSING	1	PH/PR
17	90465-13M18-00	CLAMP	2	PH/PR
18	90445-07025-00	HOSE	2	PH/PR
19	90445-07026-00	HOSE	1	PH/PR
20	90445-07027-00	HOSE	1	PH/PR
21	90464-12001-00	CLAMP	2	PH/PR
22	6AH-8552E-10-00	COVER, CASE	1	PH/PR
23	6AH-42735-10-00	PROTECTOR	2	PH/PR
24	6AH-42735-20-00	PROTECTOR	1	PH/PR
25	6AH-85537-10-00	COVER	1	PH/PR
26	90480-19368-00	GROMMET	2	PH/PR
27	6AH-85547-10-00	DAMPER	1	PH/PR
28	97095-06014-00	BOLT	3	PH/PR
29	92995-06600-00	WASHER	3	PH/PR
30	97985-06214-00	SCREW, WITH WASHER	3	PH/PR
31	6AH-85525-10-00	PLATE	1	PH/PR
32	97985-06214-00	SCREW, WITH WASHER	1	PH/PR
33	90201-06068-00	WASHER, PLATE	1	PH/PR
34	90464-76001-00	CLAMP	3	PH/PR



F15CESH 0406 / ELECTRICAL 5

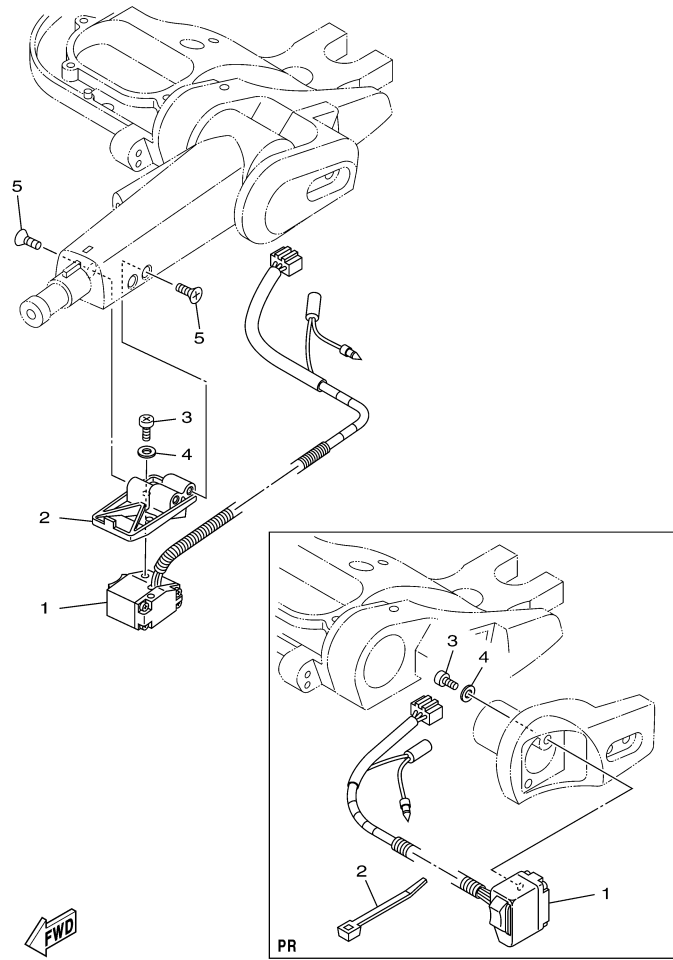

6AH1110-F170

## Part List

F15CESH 0406 / ELECTRICAL 5

REF - NO	PART NUMBER	PART NAME	QUANTITY	REMARKS
1	6AH-82563-00-00	TRIM & TILT SWITCH ASSY	1	PH/PR
2	69A-42176-00-00	STAY 2	1	PH
2	90465-11M10-00	CLAMP	2	PR
3	97885-06020-00	SCREW, PAN HEAD	2	PH/PR
4	92995-06600-00	WASHER	2	PH/PR
5	90151-06040-00	SCREW, COUNTERSUNK	3	PH

F15CESH 0406 / STARTING MOTOR

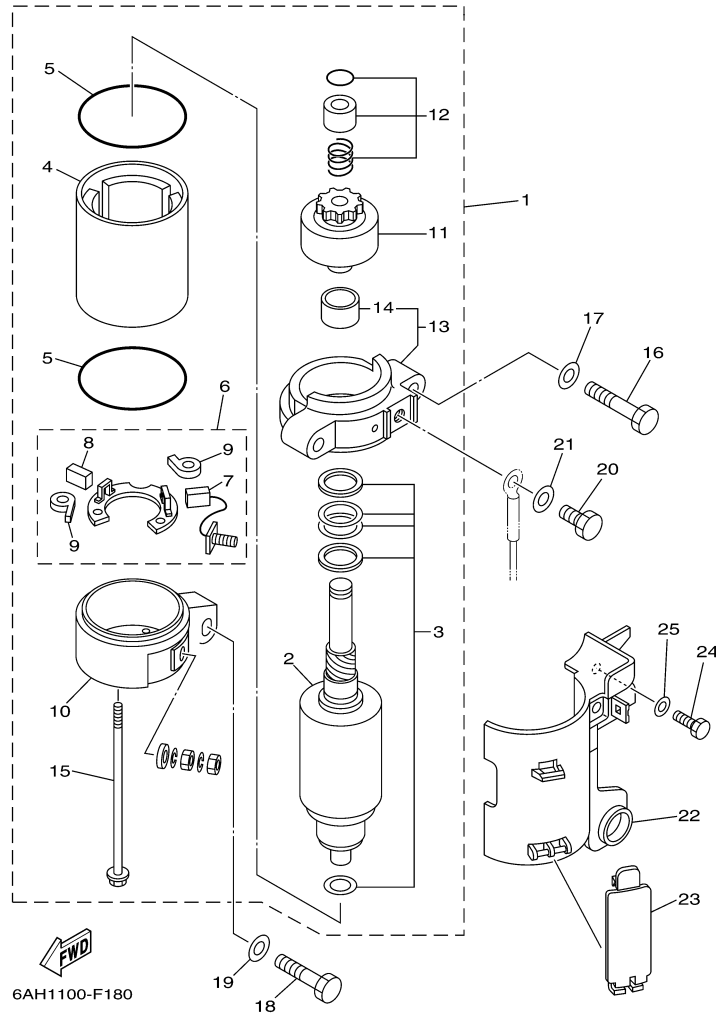

©2014 Yamaha Motor Corporation, U.S.A. All rights reserved.

## Part List

F15CESH 0406 / STARTING MOTOR

REF - NO	PART NUMBER	PART NAME	QUANTITY	REMARKS
1	6AH-81800-00-00	STARTING MOTOR ASSY	1	EH/ER/PH/PR
2	689-81850-11-00	.ARMATURE ASSY	1	
3	689-81809-11-00	.WASHER KIT	1	
4	689-81810-11-00	.STATOR ASSY	1	
5	689-81847-11-00	.O-RING	2	
6	689-81840-11-00	.BRUSH HOLDER ASSY	1	
7	689-81811-11-00	..BRUSH 1	1	
8	689-81812-11-00	..BRUSH 2	1	
9	689-81813-10-00	..SPRING, BRUSH	2	
10	6AH-81820-00-00	.REAR BRACKET ASSY	1	
11	689-81807-12-00	.GEAR ASSY, STARTING MOTOR	1	
12	68T-81857-00-00	.RETAINER	1	
13	6AH-81830-00-00	.FRONT BRACKET ASSY	1	
14	689-81831-00-00	..METAL, FRONT	1	
15	689-81826-10-00	.BOLT	2	
16	97013-08045-00	BOLT	2	EH/ER/PH/PR
17	92903-08600-00	WASHER, PLATE	2	EH/ER/PH/PR
18	97013-08035-00	BOLT	1	EH/ER/PH/PR
19	92903-08600-00	WASHER, PLATE	1	EH/ER/PH/PR
20	97095-08016-00	BOLT	1	EH/ER/PH/PR
21	92995-08600-00	WASHER	1	EH/ER/PH/PR
22	6AH-81942-00-00	COVER	1	EH/ER/PH/PR
23	6AH-82581-00-00	STAY, CORD CLAMP	1	EH/ER/PH/PR
24	97095-06014-00	BOLT	1	EH/ER/PH/PR
25	92995-06600-00	WASHER	1	EH/ER/PH/PR

F15CESH 0406 / BOTTOM COWLING

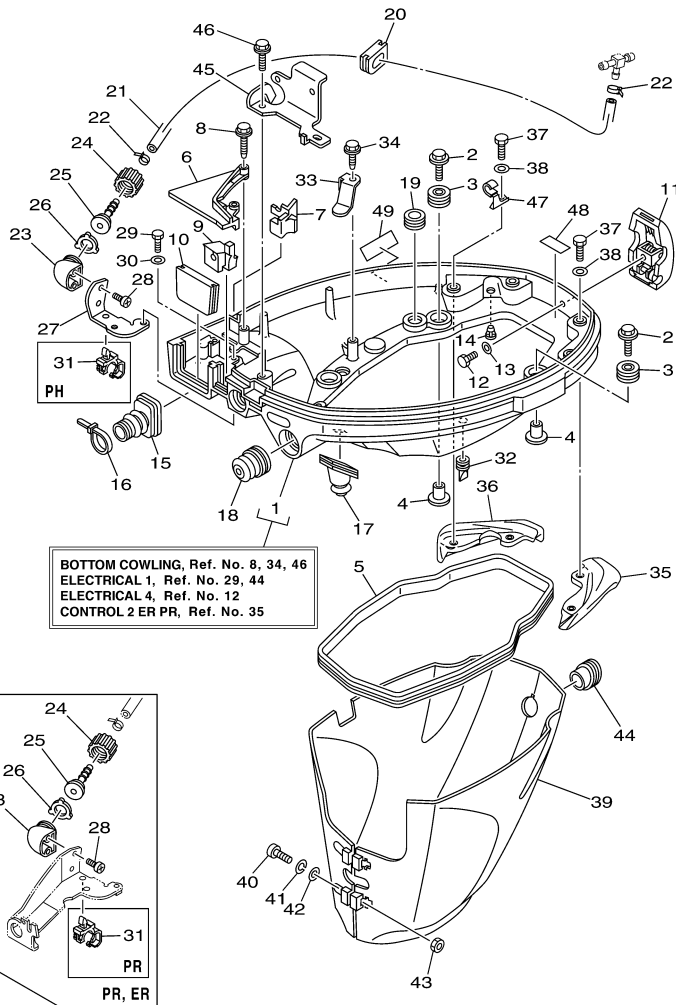

BOTTOM COWLING, Ref. No. 8, 34, 46  
 ELECTRICAL 1, Ref. No. 29, 44  
 ELECTRICAL 4, Ref. No. 12  
 CONTROL 2 ER PR, Ref. No. 35

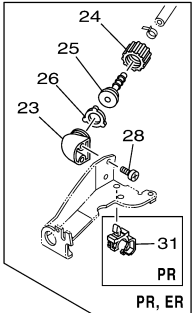

PR, ER



6AH1110-F190

## Part List

F15CESH 0406 / BOTTOM COWLING

REF - NO	PART NUMBER	PART NAME	QUANTITY	REMARKS
1	6AH-42710-10-4D	BOTTOM COWLING ASSY	1	PH/PR
1	6AH-42710-00-4D	BOTTOM COWLING ASSY	1	MH/EH/ER
2	68F-85119-00-00	BOLT	4	
3	90480-21M82-00	GROMMET	4	
4	90387-06176-00	COLLAR	4	
5	6AH-42716-00-00	RUBBER, SEAL 1	1	
6	6AH-42738-00-4D	PLATE, FITTING	1	
7	6AH-42718-00-00	RUBBER, SEAL 3	1	
8	90109-06M82-00	BOLT	2	
9	6AH-42725-00-00	GROMMET	1	MH
9	6AH-42725-20-00	GROMMET	1	ER/PR
9	6AH-42725-10-00	GROMMET	1	EH/PH
10	6AH-42724-10-00	GROMMET	1	ER/PR
10	6AH-42724-00-00	GROMMET	1	MH/EH/PH
11	6AH-42801-00-00	COWLING CLAMP COMP.	1	
12	97095-06012-00	BOLT	1	
13	92995-06600-00	WASHER	1	
14	6H3-44391-01-00	NIPPLE, HOSE	1	
15	6AH-26326-10-00	GROMMET	1	ER
15	6AH-26326-00-00	GROMMET	1	MH/EH/PH/PR
16	90465-11M10-00	CLAMP	1	MH/EH/PH/PR
17	6AH-42727-00-00	GROMMET	1	
18	65W-42726-10-00	.GROMMET	1	ER/PR
18	65W-42726-00-00	GROMMET	1	MH/EH/PH
19	90480-16007-00	GROMMET	1	
20	6AH-42726-00-00	GROMMET	1	
21	6AH-24314-00-00	PIPE 4	1	
22	90465-11M10-00	CLAMP	2	
23	68T-12572-00-00	ADAPTER	1	
24	6R3-12581-00-00	JOINT, HOSE 1	1	
25	6R3-12582-00-00	JOINT, HOSE 2	1	
26	6R3-12583-00-00	GASKET, HOSE JOINT	1	
27	6AH-12535-00-00	PLATE	1	MH/EH/PH
28	90167-06002-00	SCREW, TAPPING	2	
29	97095-06010-00	BOLT	2	MH/EH/PH
30	92995-06600-00	WASHER	2	MH/EH/PH
31	90464-12M58-00	CLAMP	1	PH/PR
32	65W-42717-00-00	RUBBER, SEAL 2	2	
33	6AH-42743-00-00	BRACKET	1	
34	90109-06M86-00	BOLT	1	
35	6AH-42761-00-00	STOPPER	1	
36	6AH-42762-00-00	STOPPER	1	
37	97075-06012-00	BOLT	4	
38	92995-06600-00	WASHER	4	
39	6AH-42741-00-00	APRON	1	
40	97885-06030-00	SCREW, PAN HEAD	2	
41	92995-06100-00	WASHER, SPRING	2	
42	92995-06600-00	WASHER	2	
43	95380-06600-00	NUT, HEXAGON	2	
44	6AH-42717-00-00	RUBBER, SEAL 2	1	
45	6AH-15774-00-00	STAY 4	1	MH/EH/ER
46	90109-06M86-00	BOLT	1	MH/EH/ER
47	90465-08M82-00	CLAMP	1	
48	6C5-82377-00-00	LABEL	1	
49	6G8-13444-41-00	MARK	1	

F15CESH 0406 / STEERING MH EH PH

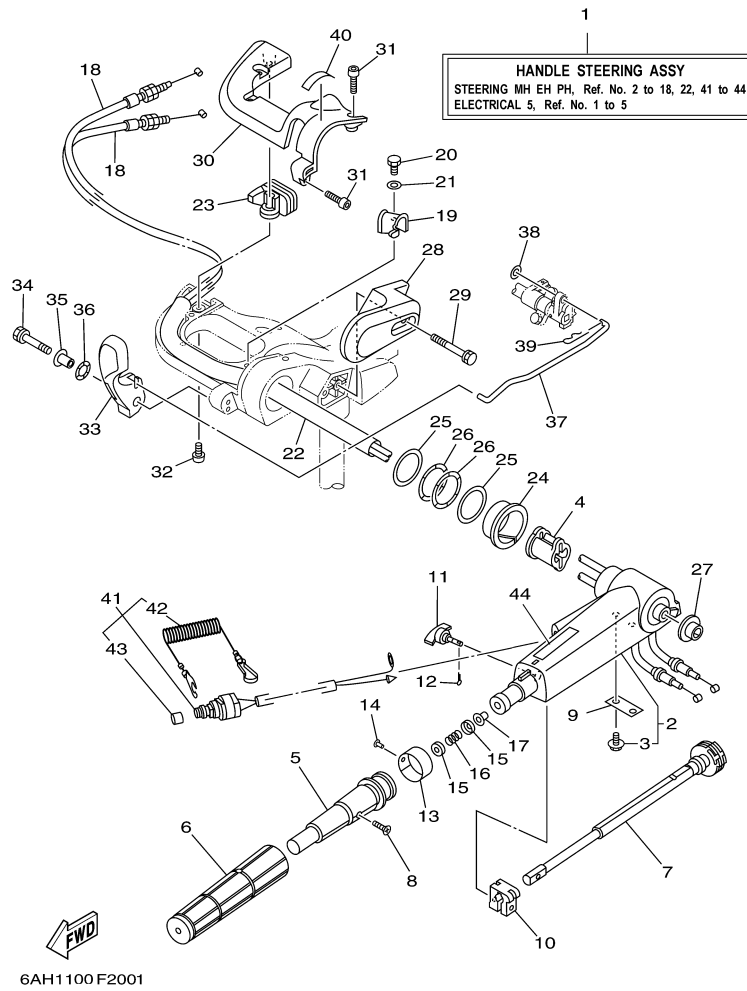

©2014 Yamaha Motor Corporation, U.S.A. All rights reserved.



## Part List

F15CESH 0406 / STEERING MH EH PH

REF - NO	PART NUMBER	PART NAME	QUANTITY	REMARKS
1	6AH-W0084-11-4D	HANDLE STEERING ASSY	1	PH
1	6AH-W0084-01-4D	HANDLE STEERING ASSY	1	MH/EH
2	6AH-42101-11-4D	HANDLE, STEERING	1	PH
2	6AH-42101-01-4D	HANDLE, STEERING	1	MH/EH
3	90109-06M86-00	.BOLT	2	
4	6AH-26288-00-00	GROMMET, CABLE	1	
5	66M-42119-00-00	GRIP, STEERING HANDLE	1	
6	67D-42177-00-00	RUBBER, HANDLE	1	
7	65W-42138-00-00	LEVER, THROTTLE	1	
8	90149-05M13-00	SCREW	1	
9	65W-42159-00-00	STAY	1	
10	6G1-42126-00-00	FRICITION, STEERING HANDLE GRIP	1	
11	65W-42125-00-00	BOLT, FRICTION ADJUSTING	1	
12	91490-16010-00	PIN. COTTER	1	
13	6J0-42137-00-00	INDICATOR, THROTTLE	1	
14	90269-02M09-00	RIVET	1	
15	6X4-44188-00-00	WASHER	2	
16	90501-23215-00	SPRING, COMPRESSION	1	
17	90386-08004-00	BUSH	1	
18	6AH-26311-00-00	CABLE, THROTTLE 1	2	
19	6AH-44554-00-00	PLATE	1	
20	97095-06014-00	BOLT	1	
21	92995-06600-00	WASHER	1	
22	6AH-2634E-00-00	PROTECTOR 1	1	
23	6AH-42551-00-00	GROMMET	1	
24	90386-45001-00	BUSH	1	
25	90201-39008-00	WASHER, PLATE	2	
26	90206-39001-00	WASHER, WAVE	2	
27	90381-20001-00	BUSH, SOLID	1	
28	6AH-42131-00-4D	COVER, HANDLE STEERING	1	
29	97595-06555-00	BOLT, WITH WASHER	2	
30	6AH-42532-00-00	COVER	1	
31	90111-06072-00	BOLT,HEX. SOCKET BUTTON	4	
32	97780-60520-00	SCREW, TAPPING	1	
33	6AH-44111-00-00	HANDLE, GEAR SHIFT	1	
34	90119-06M05-00	BOLT, WITH WASHER	1	
35	90387-06M86-00	.COLLAR	1	
36	90206-15M18-00	WASHER, WAVE	1	
37	6AH-44124-00-00	LINK, SHIFT ROD	1	
38	92990-06200-00	WASHER, PLAIN	1	
39	90468-18008-00	CLIP	1	
40	6G8-44191-00-00	INDICATOR, SHIFT	1	
41	6AH-82575-00-00	ENGINE STOP SWITCH ASSY	1	
42	682-82556-00-00	..LANYARD, STOP SWITCH	1	
43	689-8257Y-00-00	..CAP	1	
44	6E0-83627-41-00	LABEL, CAUTION 7	1	

## Part Notes

F15CESH 0406 / STEERING MH EH PH

PART NUMBER	NOTE TEXT
90468-18008-00 	OEM: This part number is among the Top 100 Most Popular Marine Maintenance Parts as of March 2014.
682-82556-00-00 	OEM: This part number is among the Top 100 Most Popular Marine Maintenance Parts as of March 2014.

©2014 Yamaha Motor Corporation, U.S.A. All rights reserved.



F15CESH 0406 / STEERING FRICTION

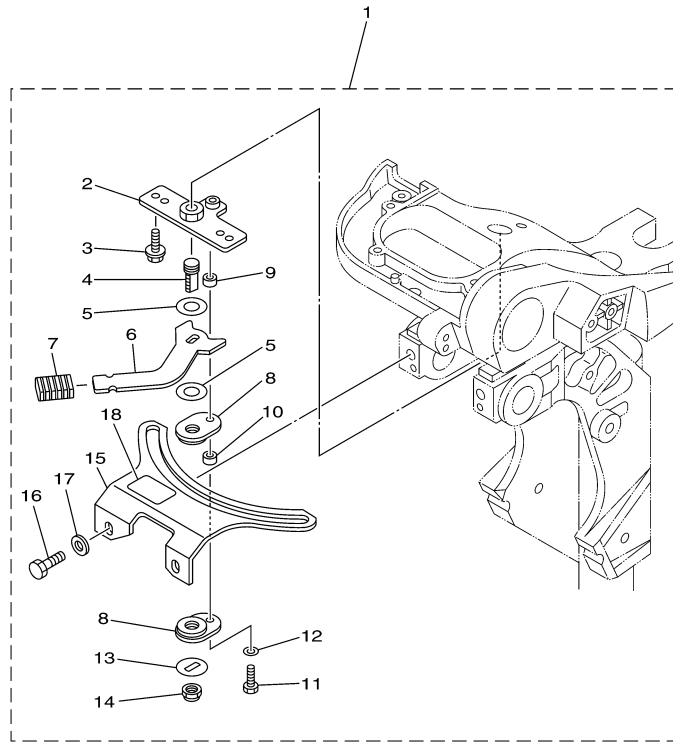

6AH1100-F210

## Part List

F15CESH 0406 / STEERING FRICTION

REF - NO	PART NUMBER	PART NAME	QUANTITY	REMARKS
1	6AH-42508-10-00	STEERING FRICTION ASSY	1	PH
1	6AH-42508-00-00	STEERING FRICTION ASSY	1	MH/EH
2	68T-42525-01-00	.PLATE, FRICTION	1	
3	90119-05018-00	.BOLT, WITH WASHER	2	
4	67C-42562-00-00	.SHAFT, STEERING LOCK	1	
5	90202-10M56-00	.WASHER, PLATE	2	
6	68T-42561-00-00	.KNOB, STEERING LOCK	1	
7	689-43633-00-00	.COVER, TILT LEVER	1	
8	65W-42528-00-00	.PLATE, FRICTION	2	
9	90387-05M05-00	.COLLAR	1	
10	90387-05M11-00	.COLLAR	1	
11	97095-05020-00	.BOLT	1	
12	92995-05600-00	.WASHER	1	
13	90209-10M26-00	.WASHER	1	
14	90185-10M14-00	.NUT, SELF-LOCKING	1	
15	6AH-42527-00-00	.PLATE, FRICTION	1	
16	90101-08022-00	.BOLT	2	
17	90201-08065-00	.WASHER, PLATE	2	
18	68T-43155-00-00	.MARK 1	1	FOR 6AH-42508-00

F15CESH 0406 / CONTROL 1 MH EH PH

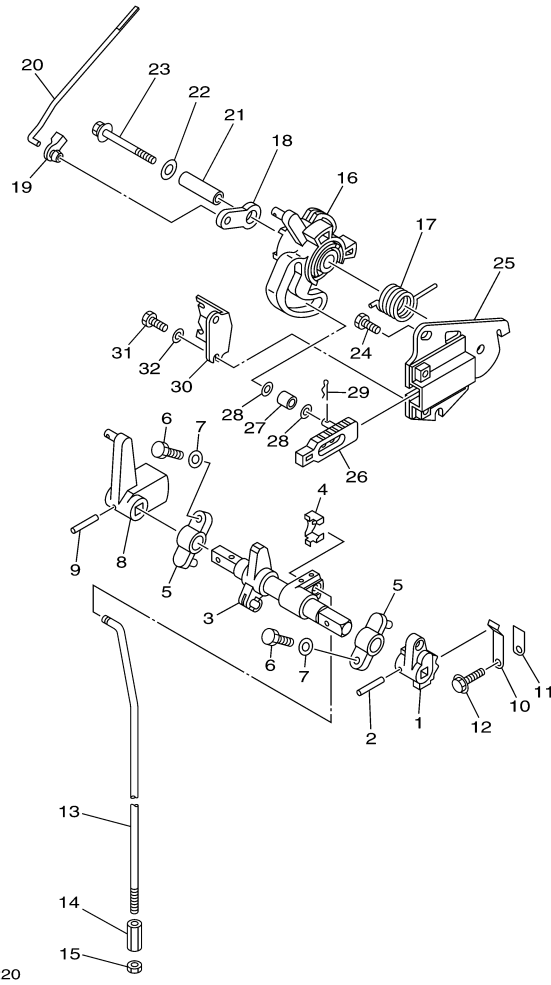

©2014 Yamaha Motor Corporation, U.S.A. All rights reserved.

## Part List

F15CESH 0406 / CONTROL 1 MH EH PH

REF - NO	PART NUMBER	PART NAME	QUANTITY	REMARKS
1	6AH-44123-00-00	ARM, SHIFT ROD	1	
2	90254-03M05-00	PIN, SPRING	1	
3	6AH-44121-00-00	LEVER, SHIFT ROD	1	
4	6AH-26364-00-00	END, CABLE 2	1	
5	6G1-41662-01-94	BRACKET 2	2	
6	97095-06020-00	BOLT	2	
7	92995-06600-00	WASHER	2	
8	6AH-44125-00-00	LEVER, SHIFT ROD	1	
9	90254-03M05-00	PIN, SPRING	1	
10	65W-44116-00-00	SPRING	1	
11	66R-44114-00-00	STOPPER	1	
12	95895-06014-00	BOLT, FLANGE	1	
13	6AH-44143-10-00	ROD, SHIFT	1	L (22.1")
13	6AH-44143-00-00	ROD, SHIFT	1	S (17.1")
14	90170-06015-00	NUT	1	
15	95380-06700-00	NUT	1	
16	6AH-41638-00-00	PULLEY	1	
17	90508-20M44-00	SPRING, TORSION	1	
18	65W-41283-00-00	.LEVER, FREE ACCEL.	1	
19	6J8-41262-00-00	JOINT, CHOKE LEVER	1	
20	6AH-41211-00-00	LINK, ACCEL.	1	
21	90387-06139-00	.COLLAR	1	
22	90201-06M31-00	.WASHER, PLATE	1	
23	97595-06555-00	BOLT, WITH WASHER	1	
24	97095-06014-00	BOLT	2	
25	6AH-14571-00-00	BRACKET, THROTTLE	1	
26	6AH-44167-00-00	PLUNGER, SHIFT CAM	1	
27	62Y-42171-00-00	BUSHING	1	
28	90201-05M04-00	WASHER, PLATE	2	
29	90468-10005-00	CLIP	1	
30	6AH-14497-00-00	STAY, THROTTLE WIRE	1	
31	97095-06014-00	BOLT	2	
32	92995-06600-00	WASHER	2	





## Part List

F15CESH 0406 / CONTROL 2 ER PR

REF - NO	PART NUMBER	PART NAME	QUANTITY	REMARKS
1	6AH-44123-00-00	ARM, SHIFT ROD	1	
2	90254-03M05-00	PIN, SPRING	1	
3	6AH-44121-00-00	LEVER, SHIFT ROD	1	
4	6AH-26364-00-00	END, CABLE 2	1	
5	6G1-41662-01-94	BRACKET 2	2	
6	97095-06020-00	BOLT	2	
7	92995-06600-00	WASHER	2	
8	6AH-44125-00-00	LEVER, SHIFT ROD	1	
9	90254-03M05-00	PIN, SPRING	1	
10	65W-44116-00-00	SPRING	1	
11	66R-44114-00-00	STOPPER	1	
12	95895-06014-00	BOLT, FLANGE	1	
13	6AH-44143-10-00	ROD, SHIFT	1	L (22.1")
13	6AH-44143-00-00	ROD, SHIFT	1	S (17.1")
14	90170-06015-00	NUT	1	
15	95380-06700-00	NUT	1	
16	6AH-48532-00-00	BRACKET, REMOTE CONTROL 2	1	
17	90480-19031-00	GROMMET	1	
18	682-48538-50-00	.CLAMP, CABLE 1	1	
19	91690-30012-00	.PIN, SPRING	1	
20	97095-06014-00	BOLT	2	
21	92995-06600-00	WASHER	2	
22	663-48344-00-00	.CABLE END, REMOTE CONTROL	1	
23	90468-18008-00	CLIP	1	
24	6AH-41638-00-00	PULLEY	1	
25	90508-20M44-00	SPRING, TORSION	1	
26	65W-41283-00-00	.LEVER, FREE ACCEL.	1	
27	6J8-41262-00-00	JOINT, CHOKE LEVER	1	
28	6AH-41211-00-00	LINK, ACCEL.	1	
29	90387-06139-00	.COLLAR	1	
30	90201-06M31-00	.WASHER, PLATE	1	
31	97595-06555-00	BOLT, WITH WASHER	1	
32	97095-06014-00	BOLT	2	
33	6AH-14571-00-00	BRACKET, THROTTLE	1	
34	6AH-48531-00-00	BRACKET, REMOTE CONTROL 1	1	
35	90109-06M86-00	BOLT	1	
36	663-48344-00-00	.CABLE END, REMOTE CONTROL	1	
37	90468-18008-00	CLIP	1	

## Part Notes

F15CESH 0406 / CONTROL 2 ER PR

PART NUMBER	NOTE TEXT
90468-18008-00 	OEM: This part number is among the Top 100 Most Popular Marine Maintenance Parts as of March 2014.
90468-18008-00 	OEM: This part number is among the Top 100 Most Popular Marine Maintenance Parts as of March 2014.

©2014 Yamaha Motor Corporation, U.S.A. All rights reserved.

F15CESH 0406 / REMO CON ATTACHMENT

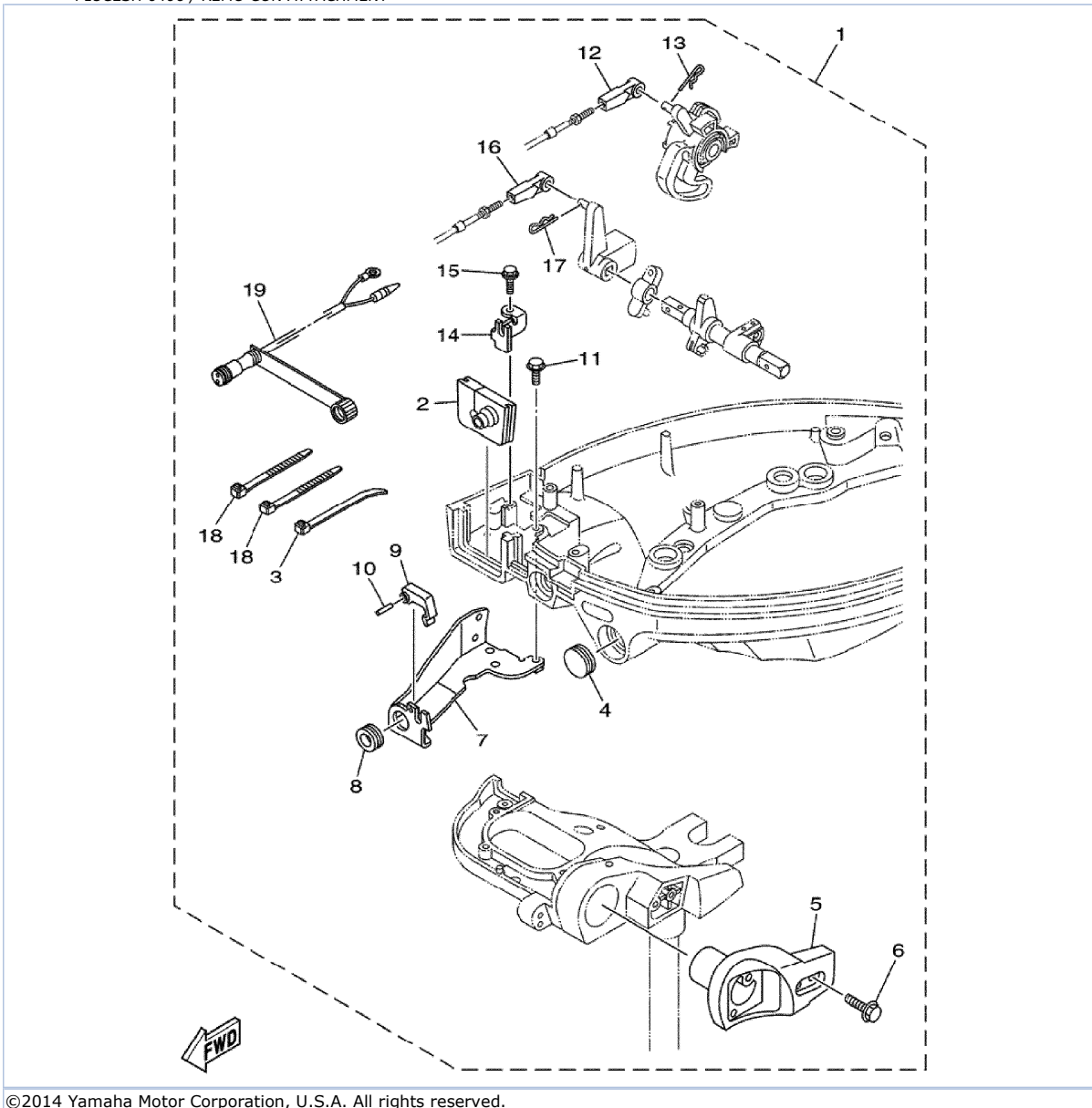

©2014 Yamaha Motor Corporation, U.S.A. All rights reserved.



## Part List

F15CESH 0406 / REMO CON ATTACHMENT

REF - NO	PART NUMBER	PART NAME	QUANTITY	REMARKS
1	6AH-48501-00-00	REMOTE CONT. ATTACHMENT ASSY.	1	
2	6AH-42724-10-00	.GROMMET	1	
3	90465-11M10-00	.CLAMP	1	
4	65W-42726-10-00	.GROMMET	1	
5	6AH-83773-00-00	.BRACKET, SWITCH	1	
6	97595-06530-00	.BOLT, WITH WASHER	2	
7	6AH-48532-00-00	.BRACKET, REMOTE CONTROL 2	1	
8	90480-19031-00	.GROMMET	1	
9	682-48538-50-00	.CLAMP, CABLE 1	1	
10	91690-30012-00	.PIN, SPRING	1	
11	97595-06514-00	.BOLT, WITH WASHER	2	
12	663-48344-00-00	.CABLE END, REMOTE CONTROL	1	
13	90468-18008-00	.CLIP	1	
14	6AH-48531-00-00	.BRACKET, REMOTE CONTROL 1	1	
15	90101-06M86-00	.BOLT	1	
16	663-48344-00-00	.CABLE END, REMOTE CONTROL	1	
17	90468-18008-00	.CLIP	1	
18	90465-13M18-00	.CLAMP	2	
19	6D5-84340-00-00	.SOCKET CORD ASSY 1	1	

## Part Notes

F15CESH 0406 / REMO CON ATTACHMENT

PART NUMBER	NOTE TEXT
90468-18008-00 	OEM: This part number is among the Top 100 Most Popular Marine Maintenance Parts as of March 2014.
90468-18008-00 	OEM: This part number is among the Top 100 Most Popular Marine Maintenance Parts as of March 2014.

©2014 Yamaha Motor Corporation, U.S.A. All rights reserved.





## Part List

F15CESH 0406 / BRACKET 1 MH EH ER

REF - NO	PART NUMBER	PART NAME	QUANTITY	REMARKS
1	6AH-43111-00-4D	BRACKET, CLAMP 1	1	
2	6E0-43118-01-00	HANDLE, TRANSOM CLAMP	1	
3	90243-04M01-00	PIN	1	
4	6E7-43116-00-00	SCREW, TRANSOM CLAMP	1	
5	648-43114-01-00	PAD, TRANSOM CLAMP	1	
6	6AH-43112-00-4D	BRACKET, CLAMP 2	1	
7	6E0-43118-01-00	HANDLE, TRANSOM CLAMP	1	
8	90243-04M01-00	PIN	1	
9	6E7-43116-00-00	SCREW, TRANSOM CLAMP	1	
10	648-43114-01-00	PAD, TRANSOM CLAMP	1	
11	63W-43131-10-00	BOLT, CLAMP BRACKET	1	ER, FOR REMOTE CONTROL
11	63W-43131-01-00	BOLT, CLAMP BRACKET	1	MH, EH
12	90386-22MA4-00	BUSH	2	
13	66R-43113-00-00	PLATE, CLAMP BRACKET	1	
14	90185-22043-00	NUT, SELF-LOCKING	2	
15	90387-06M13-00	COLLAR	1	
16	90101-06M18-00	BOLT	1	
17	92990-06600-00	WASHER, PLATE	1	
18	95380-06700-00	NUT	1	
19	6L2-43160-01-00	TILT ROD ASSY	1	
20	689-43165-00-00	..PLATE, TILT LOCK	1	
21	91690-30008-00	..PIN, SPRING	1	
22	90502-10M07-00	SPRING, CONICAL	1	
23	6AH-43311-10-4D	BRACKET, SWIVEL 1	1	L (22.1")
23	6AH-43311-00-4D	BRACKET, SWIVEL 1	1	S (17.1")
24	6AH-43631-00-00	LEVER, TILT	1	
25	6AH-43616-00-00	ROD, TILT LOCK	1	
26	6AH-43646-00-00	SHAFT, LEVER	1	
27	6AH-43641-00-00	LEVER, TILT	1	
28	6AH-43191-00-00	SHAFT, STOPPER	1	
29	99080-05600-00	CIRCLIP	1	
30	6AH-43617-00-00	ROD, TILT LOCK	1	
31	99080-05600-00	CIRCLIP	2	
32	6AH-43350-00-00	RECEIVER ASSY	1	
33	90506-18014-00	SPRING, TENSION	1	
34	6AH-43614-00-00	PLATE, TILT LOCK	1	
35	90506-20020-00	SPRING, TENSION	2	
36	6AH-43615-00-00	PLATE, TILT LOCK	1	
37	68T-43611-00-00	SHAFT, TILT LOCK	1	
38	90387-06138-00	COLLAR	2	
39	93430-04M03-00	CIRCLIP	1	
40	68T-43659-00-00	SHAFT, REVERSE LOCK	1	
41	99080-05600-00	CIRCLIP	1	
42	6AH-43627-00-00	STOPPER	2	
43	90109-06M84-00	BOLT	4	
44	90206-10M24-00	WASHER, WAVE	2	

## Part Notes

F15CESH 0406 / BRACKET 1 MH EH ER

PART NUMBER	NOTE TEXT
92990-06600-00 	OEM: This part number is among the Top 100 Most Popular Marine Maintenance Parts as of March 2014.

©2014 Yamaha Motor Corporation, U.S.A. All rights reserved.

F15CESH 0406 / BRACKET 2 PH PR

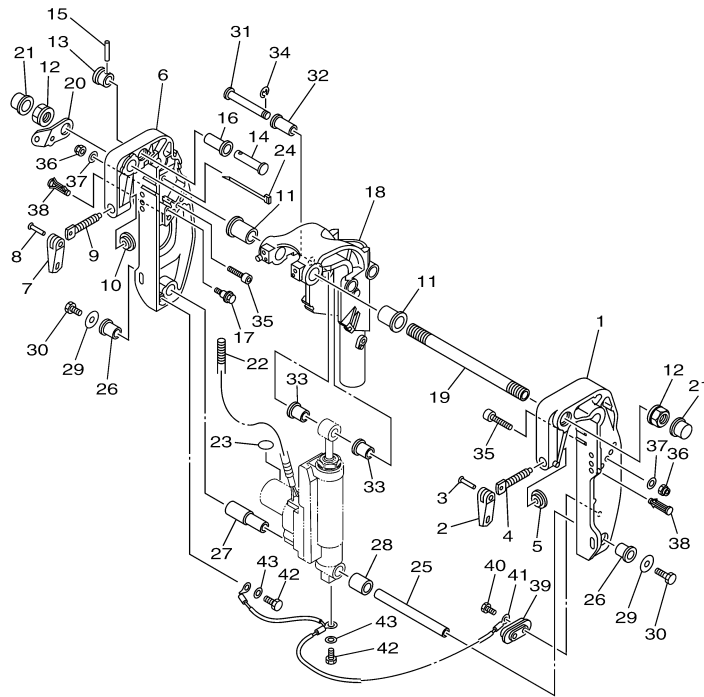

6AH1300-F240

©2014 Yamaha Motor Corporation, U.S.A. All rights reserved.

## Part List

F15CESH 0406 / BRACKET 2 PH PR

REF - NO	PART NUMBER	PART NAME	QUANTITY	REMARKS
1	69A-43111-01-4D	BRACKET, CLAMP 1	1	
2	6E0-43118-01-00	HANDLE, TRANSOM CLAMP	1	
3	90243-04M01-00	PIN	1	
4	6E7-43116-00-00	SCREW, TRANSOM CLAMP	1	
5	648-43114-01-00	PAD, TRANSOM CLAMP	1	
6	69A-43112-01-4D	BRACKET, CLAMP 2	1	
7	6E0-43118-01-00	HANDLE, TRANSOM CLAMP	1	
8	90243-04M01-00	PIN	1	
9	6E7-43116-00-00	SCREW, TRANSOM CLAMP	1	
10	648-43114-01-00	PAD, TRANSOM CLAMP	1	
11	90386-22MA4-00	BUSH	2	
12	90185-22043-00	NUT, SELF-LOCKING	2	
13	65W-43192-00-00	KNOB, STOPPER	1	
14	65W-43191-00-00	SHAFT, STOPPER	1	
15	91690-30018-00	PIN, SPRING	1	
16	90386-14MA1-00	BUSH	1	
17	90109-06M04-00	BOLT	1	
18	69A-43311-11-4D	BRACKET, SWIVEL 1	1	L (22.1")
19	69A-43131-00-00	BOLT, CLAMP BRACKET	1	UR FOR REMOTE CONTROL
20	69A-43113-00-00	PLATE, CLAMP BRACKET	1	
21	6G5-43145-01-00	CAP, CLAMP BRACKET	2	
22	90446-14MH7-00	HOSE (L560)	1	
23	69A-43155-00-00	MARK 1	1	
24	90465-13M97-00	CLAMP	1	
25	69G-43818-00-00	PIN, LOWER SHOCK MOUNT	1	
26	90386-16MA7-00	BUSH	2	
27	90386-16MA8-00	BUSH	1	
28	90387-16M02-00	COLLAR	1	
29	90201-08M00-00	WASHER, PLATE	2	
30	97080-08016-00	BOLT	2	
31	90249-12M36-00	PIN	1	
32	90381-12M10-00	BUSH, SOLID	1	
33	90381-12M11-00	BUSH, SOLID	2	
34	93430-10M00-00	CIRCLIP	1	
35	90110-08081-00	BOLT, HEXAGON SOCKET HEAD	2	
36	90185-08057-00	.NUT, SELF-LOCKING	2	
37	92990-08600-00	.WASHER, PLATE	2	
38	90338-08M19-00	PLUG	2	L (22.1")
39	65W-45251-00-00	ANODE	1	
40	90101-06020-00	BOLT	2	
41	63V-82127-00-00	WIRE, LEAD 2	1	
42	97095-06010-00	BOLT	2	
43	92995-06600-00	WASHER	2	

## Part Notes

F15CESH 0406 / BRACKET 2 PH PR

PART NUMBER	NOTE TEXT
65W-45251-00-00 	OEM: This part number is among the Top 100 Most Popular Marine Maintenance Parts as of March 2014.

©2014 Yamaha Motor Corporation, U.S.A. All rights reserved.

F15CESH 0406 / BRACKET 3

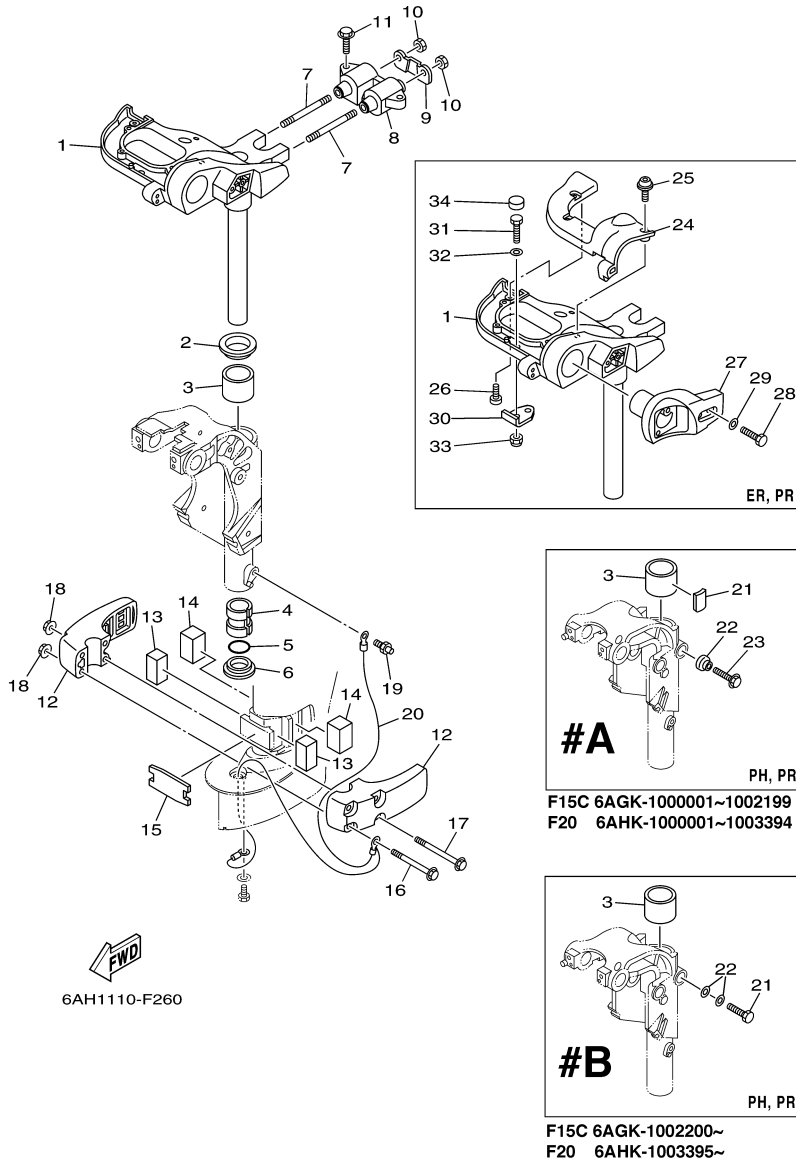

©2014 Yamaha Motor Corporation, U.S.A. All rights reserved.

## Part List

F15CESH 0406 / BRACKET 3

REF - NO	PART NUMBER	PART NAME	QUANTITY	REMARKS
1	6AH-42510-10-4D	STEERING BRACKET ASSY	1	L (22.1")
1	6AH-42510-00-4D	STEERING BRACKET ASSY	1	S (17.1")
2	90209-40008-00	WASHER	1	
3	90386-40001-00	BUSH	1	
4	90386-30048-00	BUSH	1	
5	93210-29M94-00	O-RING	1	
6	90386-30M60-00	BUSH	1	
7	90116-10033-00	BOLT, STUD	2	
8	6AH-44514-00-94	MOUNT DAMPER, UPPER SIDE	1	
9	6AH-44526-00-00	PLATE	1	
10	95380-10600-00	NUT	2	
11	90119-08094-00	BOLT, WITH WASHER	2	
12	6AH-44551-00-4D	HOUSING, LOWER MOUNT RUBBER 1	2	
13	6AH-44557-00-00	MOUNT DAMPER, LOWER FRONT	2	
14	6AH-44555-00-00	MOUNT DAMPER, LOWER SIDE	2	
15	6AH-44574-00-00	STOPPER, LOWER MOUNT RUBBER	1	
16	90119-08M45-00	BOLT, WITH WASHER	2	
17	90119-08M46-00	BOLT, WITH WASHER	2	
18	90179-08M34-00	NUT	4	
19	93700-06M03-00	NIPPLE, GREASE	1	
20	6AH-82127-10-00	WIRE, LEAD 2	1	PH/PR
20	6AH-82127-00-00	WIRE, LEAD 2	1	MH/EH/ER
21	63V-42528-00-00	PLATE, FRICTION	1	PH/PR SEE #A FOR ENG. NO.
21	97095-06014-00	BOLT	1	PH/PR SEE #B FOR ENG. NO. (USE AS A SET)
22	689-43373-01-00	SEAL, DAMPER	1	PH/PR SEE #A FOR ENG. NO.
22	92995-06600-00	WASHER	2	PH/PR SEE #B FOR ENG. NO. (USE AS A SET)
23	90105-06M07-00	.BOLT, FLANGE	1	PH/PR SEE #A FOR ENG. NO.
24	6AH-42532-10-00	COVER	1	ER/PR
25	90111-06072-00	BOLT,HEX. SOCKET BUTTON	4	ER/PR
26	97780-60520-00	SCREW, TAPPING	1	ER/PR
27	6AH-83773-00-00	BRACKET, SWITCH	1	ER/PR
28	97095-06030-00	BOLT	2	ER/PR
29	92995-06600-00	WASHER	2	ER/PR
30	6AH-48511-00-00	HOOK, STEERING	1	ER/PR
31	97095-08025-00	BOLT	1	ER/PR
32	92995-08600-00	WASHER	1	ER/PR
33	90185-08057-00	NUT, SELF-LOCKING	1	ER/PR
34	6AH-44194-00-00	CAP	1	ER/PR

F15CESH 0406 / POWER TILT ASSY

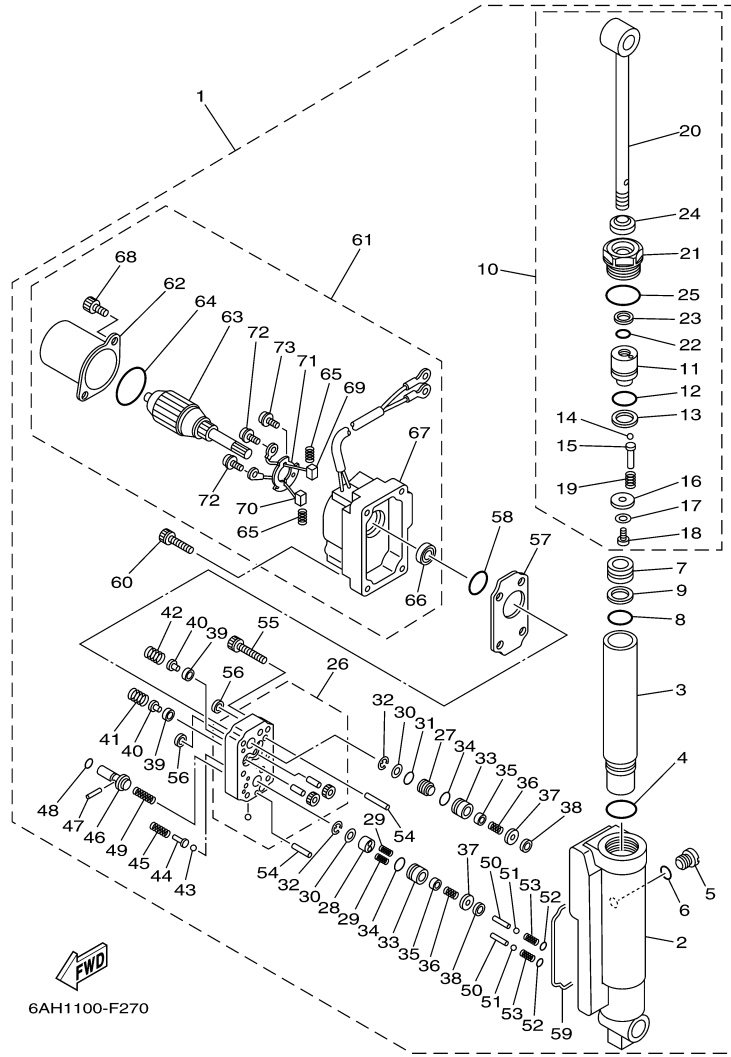

©2014 Yamaha Motor Corporation, U.S.A. All rights reserved.

## Part List

F15CESH 0406 / POWER TILT ASSY

REF - NO	PART NUMBER	PART NAME	QUANTITY	REMARKS
1	6AH-43840-00-4D	POWER TILT ASSY	1	PH/PR
2	6AH-4380K-00-00	.CYLINDER, TILT SUB ASSY	1	
3	6AH-22471-00-00	.CYLINDER, SHOCK ABSORBER	1	
4	93210-320A7-00	.O-RING	1	
5	6H1-4388E-11-00	.PLUG, TAPER SCREW	1	
6	93210-07003-00	.O-RING	1	
7	6AH-43814-00-00	.PISTON, FREE	1	
8	93210-24709-00	.O-RING	1	
9	6C5-43871-00-00	.RING, BACK UP	1	
10	6AH-43810-00-00	.TILT PISTON SUB ASSY	1	
11	6AH-4380D-00-00	.PISTON COMP	1	
12	93210-24709-00	.O-RING	1	
13	6C5-43871-00-00	.RING, BACK UP	1	
14	93501-08001-00	.BALL	5	
15	6AH-4386A-00-00	.PIN, ABSORBER VALVE	5	
16	6AH-4385E-00-00	.PLATE, PISTON	1	
17	92902-06200-00	.WASHER	1	
18	6AH-43878-00-00	.BOLT, SOCKET	1	
19	6AH-43857-00-00	.SPRING, ABSORBER VALVE	5	
20	6AH-43801-00-00	.ROD	1	
21	6AH-43811-00-00	.SCREW, CYLINDER END	1	
22	6H1-43866-00-00	.O-RING	1	
23	69A-43871-00-00	.RING, BACK UP	1	
24	69A-43812-00-00	.SEAL, DUST	1	
25	62X-43862-00-00	.O-RING	1	
26	6AH-43830-00-00	.GEAR PUMP ASSY	1	
27	69A-43841-00-00	.PISTON, SHUTTLE	1	
28	69A-4384M-00-00	.PISTON, SHUTTLE 2	1	
29	62Y-43894-00-00	.SPRING, SHUTTLE RETURN	2	
30	69A-4384F-00-00	.SEAL, MAIN VALVE	2	
31	6H1-43883-00-00	.O-RING	1	
32	99002-03600-00	.CLIP	2	
33	69G-4382G-00-00	.VALVE SEAT	2	
34	93210-12N52-00	.O-RING	2	
35	6T4-43808-00-00	.SEAT VALVE COMP 1	2	
36	69G-43853-00-00	.SPRING, MAIN VALVE	2	
37	69G-4388F-00-00	.SPACER	2	
38	69J-4381C-00-00	.FILTER 3	2	
39	6H1-4384G-11-00	.SEAL, RELIEF VALVE	2	
40	6H1-43844-10-00	.PIN, VALVE SUPPORT	2	
41	6F2-43855-00-00	.SPRING, UP RELIEF	1	
42	6H1-43856-10-00	.SPRING, DOWN RELIEF	1	
43	93501-08001-00	.BALL	2	
44	69A-4386A-00-00	.PIN, ABSORBER VALVE	2	
45	69A-43824-00-00	.SPRING, DOWN RELIEF 2	2	
46	69A-43848-00-00	.ROD, MANUAL RELEASE	1	
47	93602-15250-00	.PIN, DOWEL	1	
48	93210-06001-00	.O-RING	1	
49	6AH-43854-00-00	.SPRING, MANUAL RELEASE	1	
50	69A-4381G-00-00	.PIN 1	2	
51	93501-08001-00	.BALL	2	
52	6H1-43883-00-00	.O-RING	2	
53	69A-4384H-00-00	.SPRING	2	
54	93606-14081-00	.PIN, DOWEL	2	
55	91312-05025-00	.BOLT	6	
56	69J-4381C-00-00	.FILTER 3	2	
57	6AH-4381J-00-00	.PLATE	1	
58	N35-43862-10-00	.O-RING	1	
59	69A-23129-00-00	.GASKET, DRAIN PLUG	1	
60	69A-43878-00-00	.BOLT, SOCKET	4	



61	69A-43880-00-00	.MOTOR ASSY	1	
62	65W-43804-00-00	..STATOR ASSY	1	
63	65W-43805-00-00	..ARMATURE ASSY	1	
64	65W-43869-00-00	..O-RING	1	
65	65W-4386K-00-00	..SPRING, BRUSH	2	
66	65W-43882-00-00	..OIL SEAL	1	
67	69A-43881-00-00	..FRAME, END	1	
68	65W-43887-00-00	..BOLT	2	
69	65W-43892-00-00	..BRUSH 2	1	
70	65W-43891-00-00	..BRUSH 1	1	
71	65W-4380F-00-00	..PLATE, BRUSH HOLDER	1	
72	65W-43879-00-00	..SCREW, WITH WASHER	2	
73	65W-4388E-00-00	..BOLT	1	

F15CESH 0406 / UPPER CASING

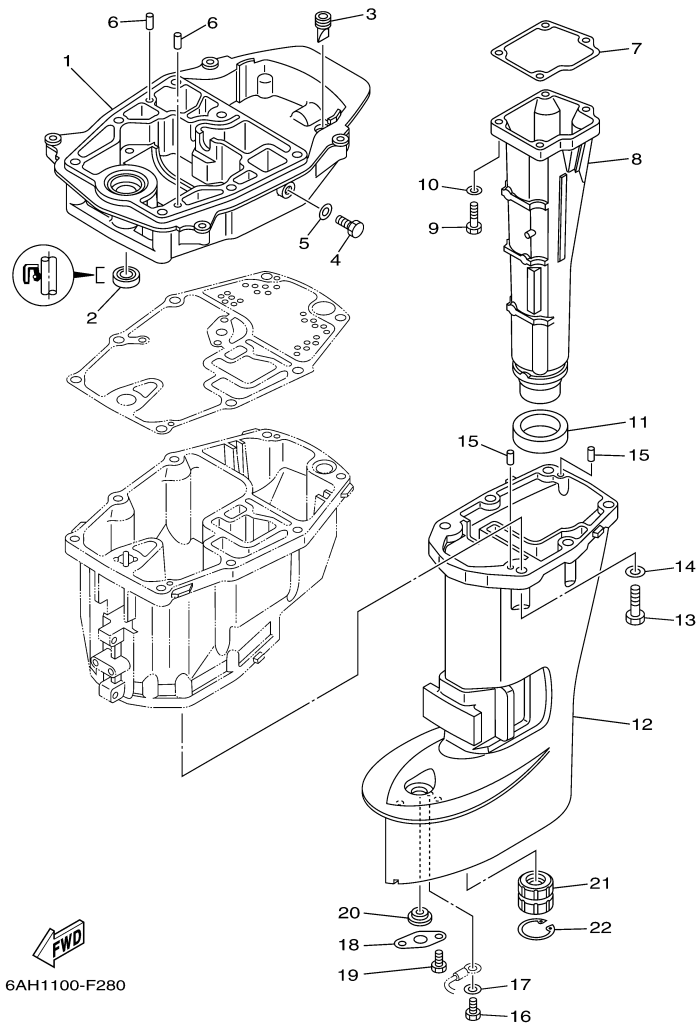

©2014 Yamaha Motor Corporation, U.S.A. All rights reserved.

## Part List

F15CESH 0406 / UPPER CASING

REF - NO	PART NUMBER	PART NAME	QUANTITY	REMARKS
1	6AH-41137-00-5B	GUIDE, EXHAUST	1	
2	93101-12M63-00	.OIL SEAL	1	
3	65W-42717-00-00	RUBBER, SEAL 2	1	
4	97095-08014-00	BOLT	1	
5	90430-08143-00	GASKET	1	
6	93606-19M23-00	PIN, DOWEL	2	
7	6AH-41134-00-00	.GASKET, EXHAUST MANIFOLD	1	
8	6AH-14711-10-5B	MUFFLER 1	1	L (22.1")
8	6AH-14711-00-5B	MUFFLER 1	1	S (17.1")
9	97075-06025-00	BOLT	4	
10	92995-06600-00	WASHER	4	
11	6AH-41138-00-00	.SEAL, EXT. 1	1	
12	6AH-45111-10-4D	CASING, UPPER	1	L (22.1")
12	6AH-45111-00-4D	CASING, UPPER	1	S (17.1")
13	97075-08030-00	BOLT	6	
14	92995-08600-00	WASHER	6	
15	93604-12M07-00	PIN, DOWEL	2	
16	97095-05010-00	BOLT	1	
17	92995-05600-00	WASHER	1	
18	68T-45321-00-00	PLATE	1	
19	97095-06008-00	BOLT	1	
20	90480-14M54-00	GROMMET	1	
21	682-45318-00-00	BUSHING, DRIVE SHAFT	1	L (22.1")
22	93420-30042-00	CIRCLIP	1	L (22.1")

F15CESH 0406 / OIL PAN

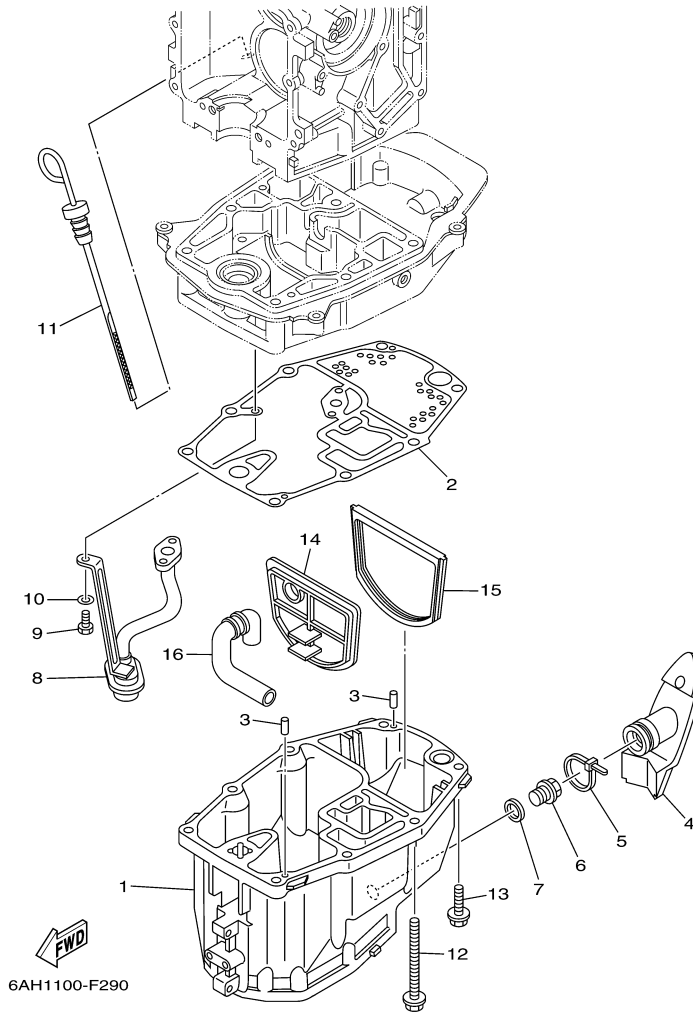

©2014 Yamaha Motor Corporation, U.S.A. All rights reserved.

## Part List

F15CESH 0406 / OIL PAN

REF - NO	PART NUMBER	PART NAME	QUANTITY	REMARKS
1	6AH-15311-00-5B	OIL PAN	1	
2	6AH-15312-00-00	.GASKET, OIL PAN	1	
3	93604-12M07-00	PIN, DOWEL	2	
4	6AH-15316-00-00	DAMPER 1	1	
5	90465-11M59-00	CLAMP	1	
6	90340-14M06-00	PLUG, STRAIGHT SCREW	1	
7	90430-14M09-00	.GASKET	1	
8	6AH-13411-00-00	STRAINER, OIL	1	
9	97013-06016-00	BOLT	3	
10	92903-06600-00	WASHER, PLATE	3	
11	6AH-15362-00-00	PLUG, OIL LEVEL	1	
12	90119-08103-00	BOLT, WITH WASHER	6	
13	90119-08102-00	BOLT, WITH WASHER	2	
14	6AH-45126-00-00	.PLATE, SEAL DAMPER	1	
15	6AH-45115-00-00	.GASKET, UPPER CASING	1	
16	6AH-45135-00-00	PIPE	1	

## Part Notes

F15CESH 0406 / OIL PAN

PART NUMBER	NOTE TEXT
90430-14M09-00 	OEM: This part number is among the Top 100 Most Popular Marine Maintenance Parts as of March 2014.

©2014 Yamaha Motor Corporation, U.S.A. All rights reserved.



## Part List

F15CESH 0406 / LOWER CASING DRIVE 1

REF - NO	PART NUMBER	PART NAME	QUANTITY	REMARKS
1	6AH-45300-10-4D	LOWER UNIT ASSY	1	L (22.1")
1	6AH-45300-00-4D	LOWER UNIT ASSY	1	S (17.1")
2	6AH-45311-00-4D	CASING, LOWER	1	
3	93315-314V8-00	BEARING	1	
4	63V-45536-00-00	SLEEVE, DRIVE SHAFT	1	
5	90209-14011-00	WASHER	1	
6	90201-15017-00	WASHER, PLATE	1	
7	6E8-45587-30-00	SHIM (T:1.20MM)	1	UR
7	6E8-45587-10-00	SHIM (T:1.13MM)	1	UR
8	93332-00005-00	BEARING	1	
9	90340-08002-00	PLUG, STRAIGHT SCREW	2	
10	90430-08020-00	.GASKET	2	
11	6AH-44311-00-00	.HOUSING, WATER PUMP	1	
12	63V-44322-00-00	.INSERT, CARTRIDGE	1	
13	6L2-44367-00-00	.DAMPER, WATER SEAL 3	1	
14	63V-44352-01-00	.IMPELLER	1	
15	664-44338-00-00	.KEY, WOODRUFF	1	
16	93210-49046-00	.O-RING	1	
17	68T-44323-00-00	.OUTER PLATE, CARTRIDGE	1	
18	93604-12M07-00	PIN, DOWEL	2	
19	97080-08045-00	BOLT	4	
20	63V-44328-00-00	PLATE	2	
21	69G-45331-01-5B	HOUSING, BEARING	1	
22	626-45316-09-00	.BUSHING, DRIVE SHAFT	1	
23	93101-20001-00	.OIL SEAL	2	
24	69G-45315-A0-00	.PACKING, LOWER CASING	1	
25	93210-06ME6-00	.O-RING	1	
26	97080-08025-00	BOLT	2	
27	6AH-44150-10-00	SHIFT CAM ASSY	1	L (22.1")
27	6AH-44150-00-00	SHIFT CAM ASSY	1	S (17.1")
28	6AH-45510-10-00	DRIVE SHAFT ASSY	1	L (22.1")
28	6AH-45510-00-00	DRIVE SHAFT ASSY	1	S (17.1")
29	63V-45551-00-00	PINION (13T)	1	
30	90179-08M06-00	NUT	1	
31	6E7-45560-01-00	GEAR 1 (27T)	1	
32	6E7-45571-00-00	GEAR 2 (27T)	1	
33	626-45577-00-00	SHIM (T:0.10MM)	1	UR
33	626-45577-10-00	SHIM (T:0.20MM)	1	UR
33	626-45577-40-00	SHIM (T:0.50MM)	1	UR
33	626-45577-30-00	SHIM (T:0.40MM)	1	UR
33	626-45577-20-00	SHIM (T:0.30MM)	1	UR
34	90201-17682-00	WASHER, PLATE	1	
35	683-45611-00-00	SHAFT, PROPELLER	1	
36	650-45635-00-00	PLUNGER, SHIFT	1	
37	682-45631-00-00	CLUTCH, DOG	1	
38	90250-05010-00	PIN, STRAIGHT	1	
39	648-45633-00-00	RING, CROSS PIN	1	
40	90501-150A0-00	SPRING, COMPRESSION	1	
41	683-45361-02-4D	CAP, LOWER CASING	1	
42	93306-00501-00	BEARING	1	
43	93315-317U2-00	BEARING	1	
44	93101-17054-00	.OIL SEAL	2	
45	93210-57M09-00	.O-RING	1	
46	93210-56M80-00	.O-RING	1	
47	97075-06020-00	BOLT	2	
48	92995-06600-00	WASHER	2	
49	664-45567-01-00	SHIM (T:0.10MM)	1	UR
49	664-45567-10-00	SHIM (T:0.12MM)	1	UR
49	664-45567-20-00	SHIM (T:0.15MM)	1	UR
49	664-45567-60-00	SHIM (T:0.50MM)	1	UR
49	664-45567-40-00	SHIM (T:0.30MM)	1	UR

49	664-45567-50-00	SHIM (T:0.40MM)	1	UR
49	664-45567-30-00	SHIM (T:0.18MM)	1	UR

**Part Notes**

*F15CESH 0406 / LOWER CASING DRIVE 1*

PART NUMBER		NOTE TEXT
90430-08020-00		OEM: This part number is among the Top 100 Most Popular Marine Maintenance Parts as of March 2014.

©2014 Yamaha Motor Corporation, U.S.A. All rights reserved.



F15CESH 0406 / LOWER CASING DRIVE 2

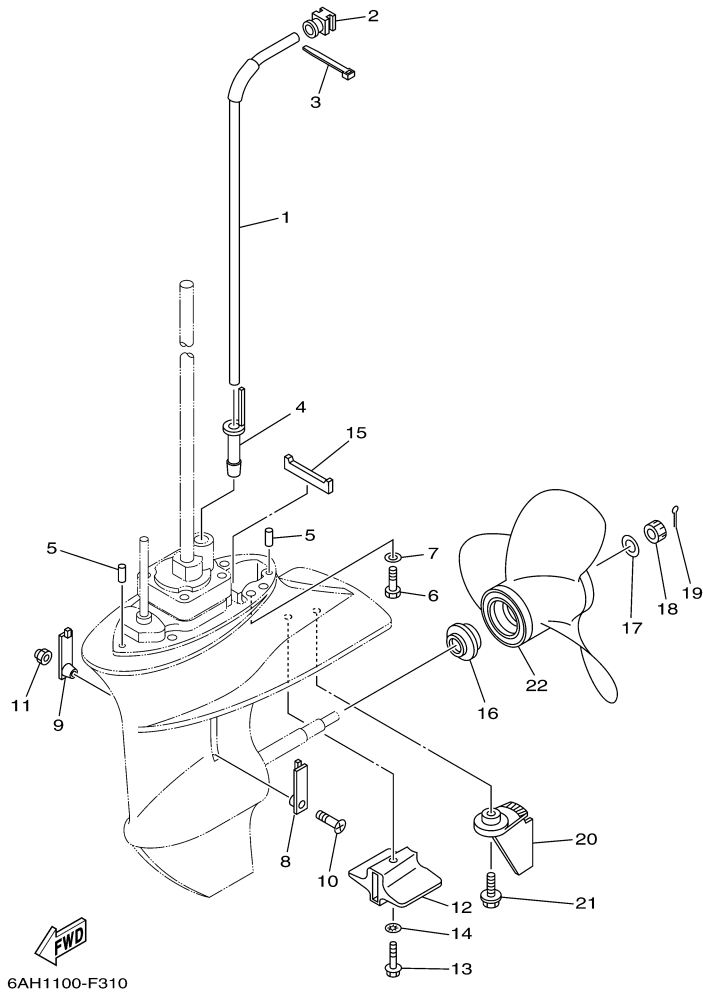

©2014 Yamaha Motor Corporation, U.S.A. All rights reserved.

## Part List

F15CESH 0406 / LOWER CASING DRIVE 2

REF - NO	PART NUMBER	PART NAME	QUANTITY	REMARKS
1	6AH-44361-10-00	TUBE, WATER	1	L (22.1")
1	6AH-44361-00-00	TUBE, WATER	1	S (17.1")
2	6AH-44365-00-00	.DAMPER, WATER SEAL 1	1	
3	90465-11M10-00	CLAMP	1	
4	6AH-44368-00-00	.RUBBER, WATER SEAL 4	1	
5	93604-12M07-00	PIN, DOWEL	2	
6	97075-08030-00	BOLT	4	
7	92995-08600-00	WASHER	4	
8	6G1-45214-00-00	COVER, WATER INLET 1	1	
9	63V-45215-00-00	COVER, WATER INLET 2	1	
10	90152-05M04-00	SCREW, COUNTERSUNK	1	
11	90185-05002-00	NUT, NYLON	1	
12	6AH-45251-00-00	ANODE	1	
13	95895-06035-00	BOLT, FLANGE	1	
14	92990-06300-00	WASHER, INTERNAL TOOTH	1	
15	63V-45375-00-00	DAMPER, SEAL	1	
16	6E7-45987-01-00	SPACER 1	1	
17	90201-10M01-00	WASHER, PLATE	1	
18	90171-10M01-00	NUT, CASTLE	1	
19	91490-30020-00	PIN. COTTER	1	
20	6AH-45371-00-4D	TAB-TRIM	1	
21	90119-06M88-00	BOLT, WITH WASHER	1	
22	683-45943-00-EL	PROPELLER (3X9-1/4"X10-1/2"-J)	1	UR
22	683-45952-00-EL	PROPELLER (3X9-1/4"X9-3/4"-J)	1	UR
22	683-45941-00-EL	PROPELLER (3X9-1/4"X12"-J)	1	UR
22	63V-45952-10-EL	PROPELLER (3X9-1/4"X10"-J1)	1	UR
22	63V-45943-10-EL	PROPELLER (3X9-1/4"X11"-J1)	1	UR
22	63V-45945-10-EL	PROPELLER (3X9-1/4"X9"-J1)	1	UR
22	63V-45941-10-EL	PROPELLER (3X9-1/4"X12"-J1)	1	UR

F15CESH 0406 / STEERING GUIDE

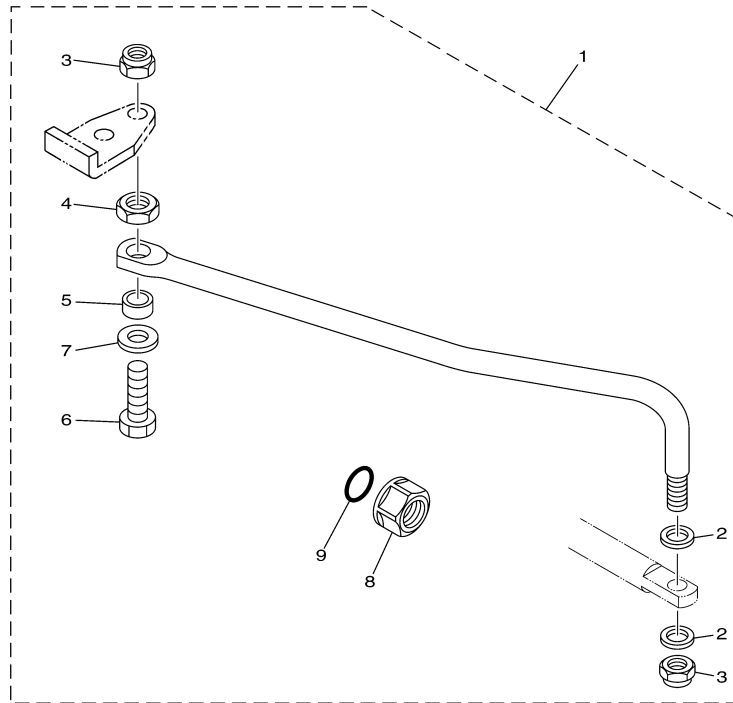

6AH1100-F340

## Part List

F15CESH 0406 / STEERING GUIDE

REF - NO	PART NUMBER	PART NAME	QUANTITY	REMARKS
1	6AH-61350-00-00	STEERING GUIDE ATTACHMENT KIT	1	AP ER/PR
2	90201-10M20-00	.WASHER, PLATE	2	
3	90185-09M01-00	.NUT, SELF-LOCKING	2	
4	90170-09M03-00	.NUT	1	
5	90387-10M42-00	.COLLAR	1	
6	6E5-61355-00-00	.BOLT	1	
7	90201-10M63-00	.WASHER, PLATE	1	
8	6E5-43145-01-00	.CAP, CLAMP BRACKET	1	
9	93210-16275-00	.O-RING	1	

F15CESH 0406 / REPAIR KIT 1

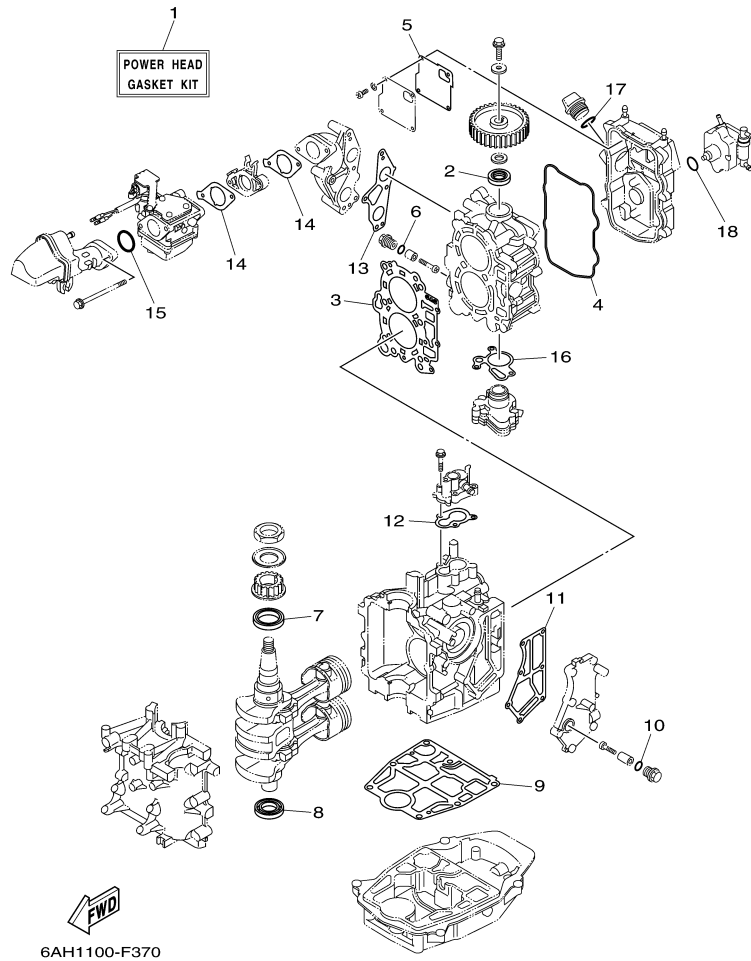

©2014 Yamaha Motor Corporation, U.S.A. All rights reserved.

## Part List

F15CESH 0406 / REPAIR KIT 1

REF - NO	PART NUMBER	PART NAME	QUANTITY	REMARKS
1	6AH-W0001-00-00	POWER HEAD GASKET KIT	1	
2	93102-22009-00	.OIL SEAL	1	
3	6AH-11181-00-00	.GASKET, CYLINDER HEAD 1	1	
4	6AH-11356-00-00	.SEAL, CYLINDER 2	1	
5	6AH-11169-00-00	.GASKET, BREATHER COVER	1	
6	93210-13M63-00	.O-RING	2	
7	93102-37004-00	.OIL SEAL	1	
8	93102-25014-00	.OIL SEAL	1	
9	6AH-11351-00-00	.GASKET, CYLINDER	1	
10	93210-13M63-00	.O-RING	1	
11	6AH-41114-00-00	.GASKET, EXHAUST OUTER COVER	1	
12	6AH-12414-00-00	.GASKET, COVER	1	
13	6AH-13645-00-00	.GASKET, MANIFOLD 1	1	
14	6AH-13646-00-00	.GASKET, MANIFOLD 2	2	
15	93210-35M86-00	.O-RING	1	
16	6AH-13329-00-00	.GASKET, PUMP COVER	1	
17	93210-24M79-00	.O-RING	1	
18	93210-20M65-00	.O-RING	1	

F15CESH 0406 / REPAIR KIT 2

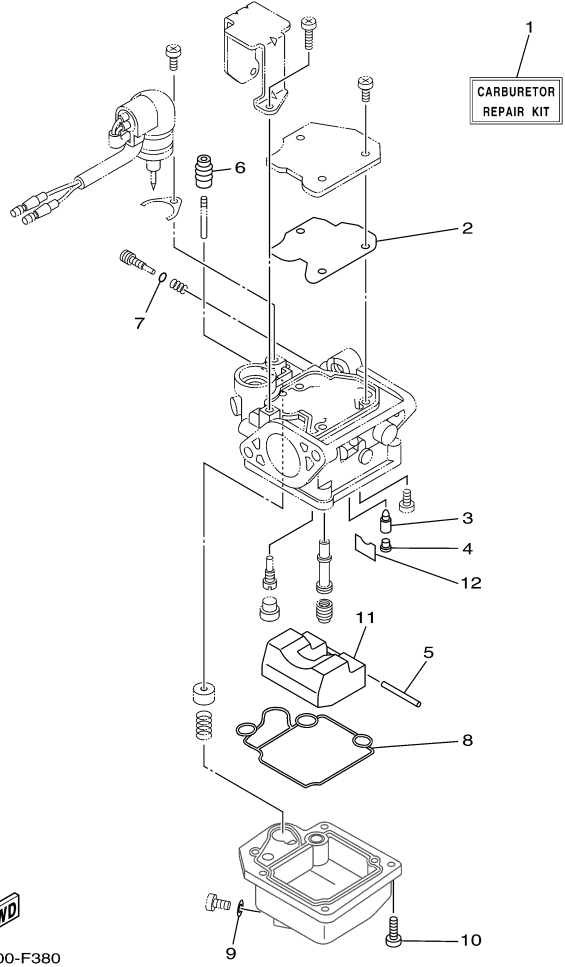

  
6AH1100-F380  
Rev. 3-20-2012

## Part List

F15CESH 0406 / REPAIR KIT 2

REF - NO	PART NUMBER	PART NAME	QUANTITY	REMARKS
1	6AH-W0093-00-00	CARBURETOR REPAIR KIT	1	
2	65W-14126-10-00	.GASKET	1	
3	6G1-14546-01-00	.VALVE, NEEDLE	1	
4	676-14186-00-00	.PIN, FLOAT	1	
5	6H4-14548-00-00	.PIN, FLOAT ARM	1	
6	65W-14373-01-00	.COVER, PLUNGER CAP	1	
7	67C-14397-00-00	.O-RING	1	
8	6AH-14384-00-00	.GASKET, FLOAT CHAMBER	1	
9	65W-14398-00-00	.GASKET	1	
10	97980-04114-00	.SCREW, WITH WASHER	4	
11	6AH-14985-00-00	.FLOAT	1	
12	663-14159-00-00	.CLIP	1	



F15CESH 0406 / REPAIR KIT 3

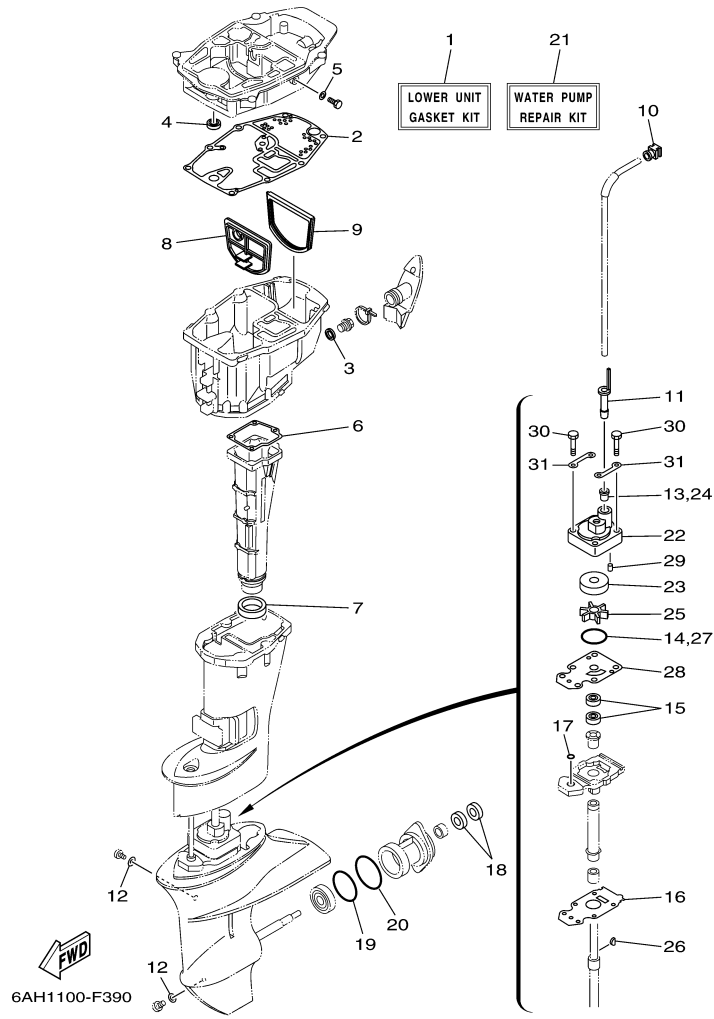

©2014 Yamaha Motor Corporation, U.S.A. All rights reserved.



## Part List

F15CESH 0406 / REPAIR KIT 3

REF - NO	PART NUMBER	PART NAME	QUANTITY	REMARKS
1	6AH-W0001-20-00	LOWER UNIT GASKET KIT	1	
2	6AH-15312-00-00	.GASKET, OIL PAN	1	
3	90430-14M09-00	.GASKET	1	
4	93101-12M63-00	.OIL SEAL	1	
5	90430-08143-00	.GASKET	1	
6	6AH-41134-00-00	.GASKET, EXHAUST MANIFOLD	1	
7	6AH-41138-00-00	.SEAL, EXT 1	1	
8	6AH-45126-00-00	.PLATE, SEAL DAMPER	1	
9	6AH-45115-00-00	.GASKET, UPPER CASING	1	
10	6AH-44365-00-00	.DAMPER, WATER SEAL 1	1	
11	6AH-44368-00-00	.RUBBER, WATER SEAL 4	1	
12	90430-08020-00	.GASKET	2	
13	6L2-44367-00-00	.DAMPER, WATER SEAL 3	1	
14	93210-49046-00	.O-RING	1	
15	93101-20001-00	.OIL SEAL	2	
16	69G-45315-A0-00	.PACKING, LOWER CASING	1	
17	93210-06ME6-00	.O-RING	1	
18	93101-17054-00	.OIL SEAL	2	
19	93210-57M09-00	.O-RING	1	
20	93210-56M80-00	.O-RING	1	
21	6AH-W0078-00-00	WATER PUMP REPAIR KIT	1	
22	6AH-44311-00-00	.HOUSING, WATER PUMP	1	
23	63V-44322-00-00	.INSERT, CARTRIDGE	1	
24	6L2-44367-00-00	.DAMPER, WATER SEAL 3	1	
25	63V-44352-01-00	.IMPELLER	1	
26	664-44338-00-00	.KEY, WOODRUFF	1	
27	93210-49046-00	.O-RING	1	
28	68T-44323-00-00	.OUTER PLATE, CARTRIDGE	1	
29	93604-12M07-00	.PIN, DOWEL	2	
30	97080-08045-00	.BOLT	4	
31	63V-44328-00-00	.PLATE	2	

## Part Notes

F15CESH 0406 / REPAIR KIT 3

PART NUMBER		NOTE TEXT
90430-14M09-00		OEM: This part number is among the Top 100 Most Popular Marine Maintenance Parts as of March 2014.
90430-08020-00		OEM: This part number is among the Top 100 Most Popular Marine Maintenance Parts as of March 2014.

©2014 Yamaha Motor Corporation, U.S.A. All rights reserved.

## F15CESH 0406 / MODELS IN THIS CATALOG

F15CMSH 6AGK-1000001~1005905  
F15CMLH 6AGK-1000001~1005905  
F15CESH 6AGK-1000001~1005905  
F15CELH 6AGK-1000001~1005905  
F15CPLH 6AGK-1000001~1005905  
(6AG1)

F20ELH 6AHK-1000001~1008550  
F20ELR 6AHK-1000001~1008550  
F20ESH 6AHK-1000001~1008550  
F20ESR 6AHK-1000001~1008550  
F20MSH 6AHK-1000001~1008550  
F20MLH 6AHK-1000001~1008550  
F20PLH 6AHK-1000001~1008550  
F20PLR 6AHK-1000001~1008550  
(6AH1)

**ALL THESE MODELS USE THIS SAME PARTS CATALOG.  
BE SURE TO ORDER ONLY THOSE PARTS APPLICABLE  
TO THE DESIRED MODEL.**

©2014 Yamaha Motor Corporation, U.S.A. All rights reserved.