

F90TLR 0406 / TOP COWLING

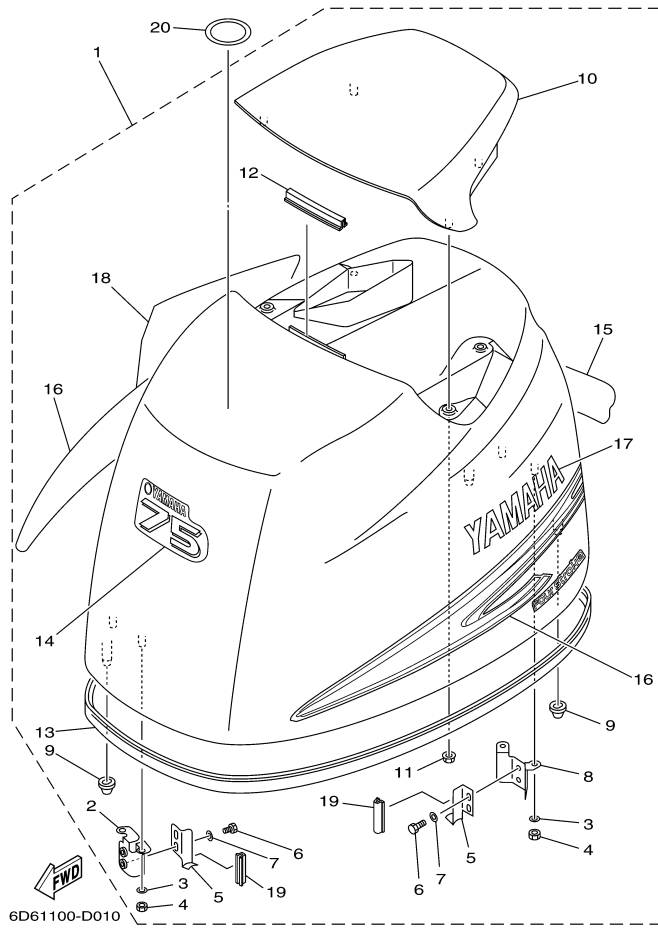

©2014 Yamaha Motor Corporation, U.S.A. All rights reserved.

## Part List

F90TLR 0406 / TOP COWLING

REF - NO	PART NUMBER	PART NAME	QUANTITY	REMARKS
1	6D8-42610-00-4D	TOP COWLING ASSY	1	UR F90
1	6D8-42610-A0-4D	TOP COWLING ASSY	1	UR F90TJR
2	67F-42647-00-00	.HOLDER, CLAMP BAND	1	
3	92990-06100-00	.WASHER, SPRING	4	
4	95380-06600-00	.NUT, HEXAGON	4	
5	68V-42652-00-00	.HOOK	2	
6	97095-06012-00	.BOLT	4	
7	92995-06600-00	.WASHER	4	
8	67F-42649-00-00	.HOLDER, CLAMP BAND	1	
9	67F-42662-00-00	.DAMPER	3	
10	67F-42613-00-4D	.MOLDING, AIR DUCT	1	
11	90179-06M24-00	.NUT	4	
12	61N-42628-00-00	.SEAL	1	
13	67F-42615-00-00	.SEAL	1	
14	61P-42677-00-00	.GRAPHIC, FRONT	1	UR F90
14	61P-42677-A0-00	.GRAPHIC, FRONT	1	UR F90TJR
15	6D8-42678-00-00	.GRAPHIC, REAR	1	UR F90
15	6D8-42678-A0-00	.GRAPHIC, REAR	1	UR F90TJR
16	67F-W0070-10-00	.GRAPHIC SET	1	
17	67F-42681-10-00	.MARK, COWLING	1	
18	67F-42682-10-00	.MARK, COWLING	1	
19	67F-42628-00-00	.SEAL	2	
20	67F-13434-03-00	LABEL, CAUTION	1	

F90TLR 0406 / CYLINDER CRANKCASE 1

- 1
- CYLINDER BLOCK ASSY**
- CYLINDER CRANKCASE 1, Ref. No. 2 - 10,  
12 - 18, 20 - 31, 35 - 37, 39 - 45
  - CRANKSHAFT PISTON, Ref. No. 1 - 10
  - CYLINDER CRANKCASE 2, Ref. No. 14
  - VALVE, Ref. No. 23 - 25
  - INTAKE 2, Ref. No. 21 - 25
  - FUEL INJECTION PUMP 1, Ref. No. 1
  - FUEL INJECTION PUMP 2, Ref. No. 7, 17
  - GENERATOR, Ref. No. 8
  - ELECTRICAL 1, Ref. No. 30
  - ELECTRICAL 3, Ref. No. 10 - 12
  - ELECTRICAL 4, Ref. No. 4 - 11
  - BOTTOM COWLING, Ref. No. 24
  - OIL PAN, Ref. No. 30

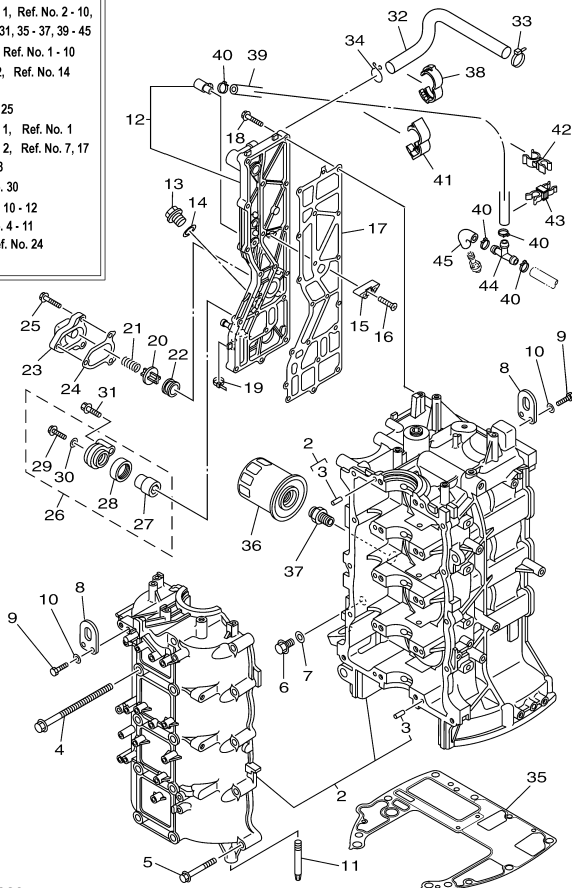



## Part List

F90TLR 0406 / CYLINDER CRANKCASE 1

REF - NO	PART NUMBER	PART NAME	QUANTITY	REMARKS
1	6D8-W009B-03-1S	CYLINDER BLOCK ASSY	1	UR FOR 62P-1009564~ 61P-1024598~
1	6D8-W009B-02-1S	CYLINDER BLOCK ASSY	1	
2	6D8-15100-01-1S	CRANKCASE ASSY	1	
3	93606-12019-00	.PIN, DOWEL	10	
4	90119-10M88-00	BOLT, WITH WASHER	10	
5	90119-08M66-00	BOLT, WITH WASHER	10	
6	90340-14M06-00	PLUG, STRAIGHT SCREW	1	
7	90430-14115-00	.GASKET	1	
8	62Y-11119-00-00	HANGER, ENGINE	2	
9	97095-06020-00	BOLT	4	
10	92995-06600-00	WASHER	4	
11	67F-15142-00-00	GUIDE 1	2	
12	6D8-41113-10-1S	OUTER COVER, EXHAUST	1	UR FOR 62P-1009564~ 61P-1024598~
12	6D8-41113-00-1S	OUTER COVER, EXHAUST	1	
13	90340-18M09-00	PLUG, STRAIGHT SCREW	1	
14	90430-18130-00	.GASKET	1	
15	6E5-11325-00-00	ANODE	3	
16	98780-04016-00	SCREW, FLAT HEAD	3	
17	67F-41114-A2-00	.GASKET, EXHAUST OUTER COVER	1	UR FOR 62P-1009564~ 61P-1024598~
17	67F-41114-A1-00	GASKET, EXHAUST OUTER COVER	1	
18	90119-06MA4-00	BOLT, WITH WASHER	18	
19	90465-11M10-00	CLAMP	1	
20	6G5-12416-00-00	VALVE, PRESSURE CONTROL	1	
21	90501-16M11-00	SPRING, COMPRESSION	1	
22	90480-20M05-00	GROMMET	1	
23	67F-1246A-01-1S	COVER 1	1	
24	67F-12435-A0-00	.GASKET	1	
25	90119-06MA2-00	BOLT, WITH WASHER	3	
26	69J-11301-10-00	ANODE COVER ASSY	1	
27	68V-11325-02-00	.ANODE	1	
28	67F-11328-00-00	.GROMMET, ANODE	1	
29	90105-06M07-00	.BOLT, FLANGE	1	
30	90430-06M03-00	.GASKET	1	
31	97575-08540-00	BOLT, WITH WASHER	1	
32	67F-1243A-00-00	HOSE 1	1	
33	90465-11M10-00	CLAMP	1	
34	90467-20M15-00	CLIP	1	
35	68V-11351-00-00	.GASKET, CYLINDER	1	
36	5GH-13440-00-00	ELEMENT ASSY, OIL CLEANER	1	
37	90401-20145-00	BOLT, UNION	1	
38	90464-16001-00	CLAMP	1	
39	6D8-42541-00-00	PIPE 1	1	UR FOR 62P-1009564~ 61P-1024598~
40	90465-11M10-00	CLAMP	4	UR FOR 62P-1009564~ 61P-1024598~
41	90464-16003-00	CLAMP	1	UR FOR 62P-1009564~ 61P-1024598~
42	90464-10010-00	CLAMP	1	UR FOR 62P-1009564~ 61P-1024598~
43	90464-11009-00	CLAMP	1	UR FOR 62P-1009564~ 61P-1024598~
44	688-24378-00-00	PIPE, JOINT 3	1	UR FOR 62P-1009564~ 61P-1024598~
45	61A-24316-00-00	PIPE 6	1	UR FOR 62P-1009564~ 61P-1024598~

## Part Notes

F90TLR 0406 / CYLINDER CRANKCASE 1

PART NUMBER	NOTE TEXT
90480-20M05-00 	OEM: This part number is among the Top 100 Most Popular Marine Maintenance Parts as of March 2014.
68V-11325-02-00 	OEM: This part number is among the Top 100 Most Popular Marine Maintenance Parts as of March 2014.
67F-11328-00-00 	OEM: This part number is among the Top 100 Most Popular Marine Maintenance Parts as of March 2014.

©2014 Yamaha Motor Corporation, U.S.A. All rights reserved.



## Part List

F90TLR 0406 / CRANKSHAFT PISTON

REF - NO	PART NUMBER	PART NAME	QUANTITY	REMARKS
1	6D8-11411-00-00	CRANKSHAFT	1	
2	67F-11416-00-00	PLANE BEARING, CRANKSHAFT 1	4	UR GREEN
2	67F-11416-20-00	PLANE BEARING, CRANKSHAFT 1	4	UR RED
2	67F-11416-10-00	PLANE BEARING, CRANKSHAFT 1	4	UR BLUE
3	67F-11417-00-00	PLANE BEARING, CRANKSHAFT 2	5	UR YELLOW
3	67F-11417-30-00	PLANE BEARING, CRANKSHAFT 2	5	UR RED
3	67F-11417-20-00	PLANE BEARING, CRANKSHAFT 2	5	UR BLUE
3	67F-11417-10-00	PLANE BEARING, CRANKSHAFT 2	5	UR GREEN
4	67F-11418-00-00	PLANE BEARING, CRANKSHAFT 3	1	UR GREEN
4	67F-11418-20-00	PLANE BEARING, CRANKSHAFT 3	1	UR RED
4	67F-11418-10-00	PLANE BEARING, CRANKSHAFT 3	1	UR BLUE
5	6D8-W1164-10-00	PISTON/CON-ROD ASSY (0.25MM OS)	4	AP
5	6D8-W1164-00-00	PISTON/CON-ROD ASSY (STD)	4	
6	67F-11654-00-00	.BOLT, CONNECTING ROD	2	
7	6D8-11604-01-00	PISTON RING SET (0.25MM O/S)	4	AP
7	6D8-11603-01-00	PISTON RING SET (STD)	4	
8	6D8-11656-00-00	PLANE BEARING, CONNECTING ROD	8	UR YELLOW
8	6D8-11656-30-00	PLANE BEARING, CONNECTING ROD	8	UR RED
8	6D8-11656-20-00	PLANE BEARING, CONNECTING ROD	8	UR BLUE
8	6D8-11656-10-00	PLANE BEARING, CONNECTING ROD	8	UR GREEN
9	93102-48008-00	.OIL SEAL	1	
10	93101-48001-00	.OIL SEAL	1	

F90TLR 0406 / CYLINDER CRANKCASE 2

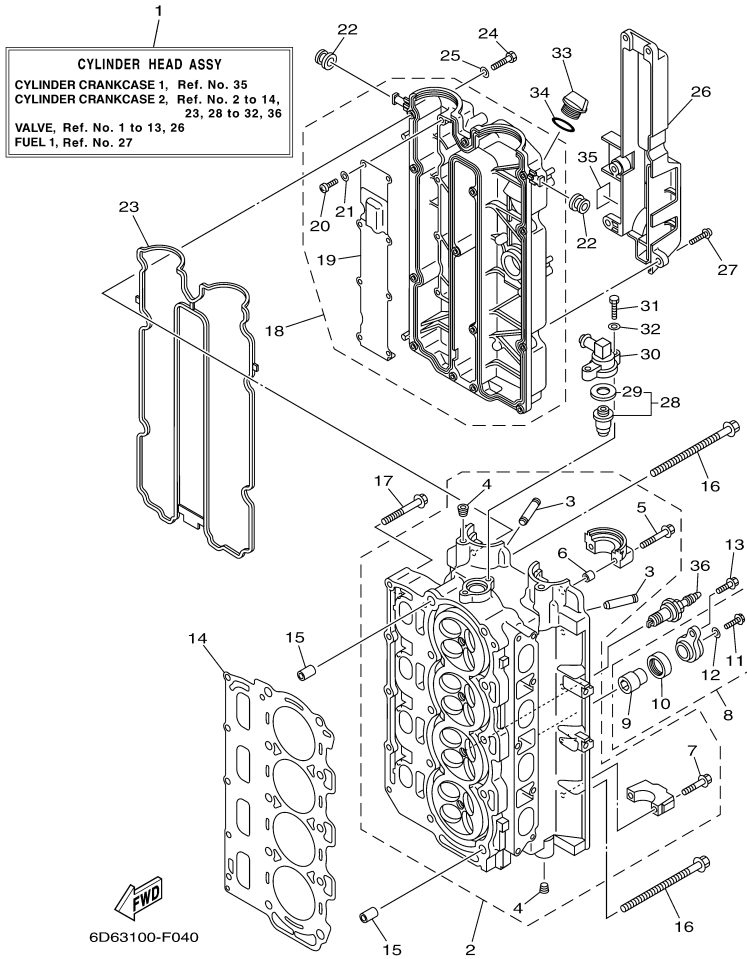

©2014 Yamaha Motor Corporation, U.S.A. All rights reserved.





## Part List

F90TLR 0406 / CYLINDER CRANKCASE 2

REF - NO	PART NUMBER	PART NAME	QUANTITY	REMARKS
1	6D8-W009A-02-1S	CYLINDER HEAD COMPLETE	1	
2	6D8-11110-01-94	CYLINDER HEAD ASSY	1	
3	67F-11133-10-00	.GUIDE, VALVE 1	16	
4	90344-51019-00	.PLUG, TAPER SCREW	4	
5	90119-07235-00	.BOLT/WASHER-CAM CAPS	4	
6	91809-08006-00	.PIN, DOWEL	4	
7	K0F-A9904-20-00	.BOLT, WITH WASHER	16	
8	69J-11301-10-00	ANODE COVER ASSY	2	
9	68V-11325-02-00	.ANODE	1	
10	67F-11328-00-00	.GROMMET, ANODE	1	
11	90105-06M07-00	.BOLT, FLANGE	1	
12	90430-06M03-00	.GASKET	1	
13	97575-08540-00	BOLT, WITH WASHER	2	
14	67F-11181-03-00	.GASKET, CYLINDER HEAD 1	1	
15	90387-10M08-00	COLLAR	2	
16	90105-10M89-00	BOLT, FLANGE	10	
17	90119-08M91-00	BOLT, WITH WASHER	5	
18	6D8-11191-00-1S	COVER, CYLINDER HEAD 1	1	
19	67F-11168-00-00	.COVER, BREATHER	1	
20	98507-04008-00	.SCREW, PAN HEAD	8	
21	92907-04600-00	.WASHER	8	
22	90480-12072-00	GROMMET	2	
23	6D8-11356-01-00	.SEAL, CYLINDER 2	1	
24	97095-06030-00	BOLT	14	
25	92995-06600-00	WASHER	14	
26	67F-11192-01-00	COVER, CYLINDER HEAD 2	1	
27	90159-06M29-00	SCREW, WITH WASHER	5	
28	67F-12411-01-00	THERMOSTAT	1	
29	67F-12412-00-00	.SEAL, THERMOSTAT	1	
30	68V-12413-00-1S	COVER, THERMOSTAT	1	
31	97095-06025-00	BOLT	2	
32	92995-06600-00	WASHER	2	
33	6G8-15363-00-00	PLUG, OIL	1	
34	93210-24M79-00	.O-RING	1	
35	6D8-83626-00-00	MARK 6	1	
36	NGK-LFR5A-11-00	PLUG, SPARK (NGK LFR5A-11)	4	

## Part Notes

F90TLR 0406 / CYLINDER CRANKCASE 2

PART NUMBER		NOTE TEXT
68V-11325-02-00		OEM: This part number is among the Top 100 Most Popular Marine Maintenance Parts as of March 2014.
67F-11328-00-00		OEM: This part number is among the Top 100 Most Popular Marine Maintenance Parts as of March 2014.
90480-12072-00		OEM: GROMMET used on F115TLR and F/LF115TXR 0410 Production and Earlier
67F-12411-01-00		OEM: This part number is among the Top 100 Most Popular Marine Maintenance Parts as of March 2014.

©2014 Yamaha Motor Corporation, U.S.A. All rights reserved.



F90TLR 0406 / VALVE

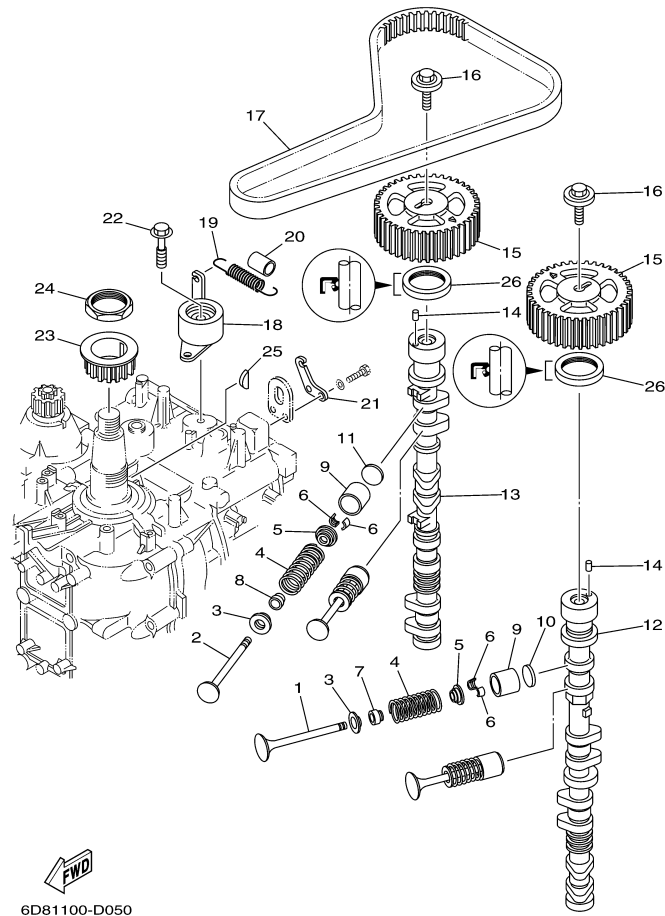

6D81100-D050

©2014 Yamaha Motor Corporation, U.S.A. All rights reserved.

## Part List

F90TLR 0406 / VALVE

REF - NO	PART NUMBER	PART NAME	QUANTITY	REMARKS
1	68V-12111-00-00	VALVE, INTAKE	8	
2	68V-12121-00-00	VALVE, EXHAUST	8	
3	67F-12116-00-00	SEAT, VALVE SPRING	16	
4	67F-12114-00-00	SPRING, VALVE OUTER	16	
5	67F-12117-00-00	RETAINER, VALVE SPRING	16	
6	67F-12118-00-00	COTTER, VALVE	32	
7	K0A-A3721-00-00	SEAL, VALVE STEM	8	
8	K0A-A3722-00-00	SEAL, VALVE STEM 2	8	
9	67F-12153-00-00	LIFTER, VALVE	16	
10	67F-12168-00-00	PAD, ADJUSTING (2.000)	16	UR
10	67F-12168-Y0-00	PAD, ADJUSTING (2.750)	16	UR
10	67F-12168-20-00	PAD, ADJUSTING (2.050)	16	UR
10	67F-12168-30-00	PAD, ADJUSTING (2.075)	16	UR
10	67F-12168-40-00	PAD, ADJUSTING (2.100)	16	UR
10	67F-12168-50-00	PAD, ADJUSTING (2.125)	16	UR
10	67F-12168-60-00	PAD, ADJUSTING (2.150)	16	UR
10	67F-12168-70-00	PAD, ADJUSTING (2.175)	16	UR
10	67F-12168-80-00	PAD, ADJUSTING (2.200)	16	UR
10	67F-12168-A0-00	PAD, ADJUSTING (2.225)	16	UR
10	67F-12168-B0-00	PAD, ADJUSTING (2.250)	16	UR
10	67F-12168-C0-00	PAD, ADJUSTING (2.275)	16	UR
10	67F-12168-D0-00	PAD, ADJUSTING (2.300)	16	UR
10	67F-12168-E0-00	PAD, ADJUSTING (2.325)	16	UR
10	67F-12168-F0-00	PAD, ADJUSTING (2.350)	16	UR
10	67F-12168-G0-00	PAD, ADJUSTING (2.375)	16	UR
10	67F-12168-H0-00	PAD, ADJUSTING (2.400)	16	UR
10	67F-12168-J0-00	PAD, ADJUSTING (2.425)	16	UR
10	67F-12168-K0-00	PAD, ADJUSTING (2.450)	16	UR
10	67F-12168-L0-00	PAD, ADJUSTING (2.475)	16	UR
10	67F-12168-M0-00	PAD, ADJUSTING (2.500)	16	UR
10	67F-12168-N0-00	PAD,ADJUSTING (2.525)	16	UR
10	67F-12168-P0-00	PAD, ADJUSTING (2.550)	16	UR
10	67F-12168-R0-00	PAD, ADJUSTING (2.575)	16	UR
10	67F-12168-S0-00	PAD, ADJUSTING (2.600)	16	UR
10	67F-12168-T0-00	PAD, ADJUSTING (2.625)	16	UR
10	67F-12168-U0-00	PAD, ADJUSTING (2.650)	16	UR
10	67F-12168-V0-00	PAD, ADJUSTING (2.675)	16	UR
10	67F-12168-W0-00	PAD, ADJUSTING (2.700)	16	UR
10	67F-12168-X0-00	PAD, ADJUSTING (2.725)	16	UR
10	67F-12168-10-00	PAD, ADJUSTING (2.025)	16	UR
11	67F-12169-00-00	PAD, ADJUSTING (2.775)	16	UR
11	67F-12169-N0-00	PAD, ADJUSTING (3.300)	16	UR
11	67F-12169-20-00	PAD, ADJUSTING (2.825)	16	UR
11	67F-12169-30-00	PAD, ADJUSTING (2.850)	16	UR
11	67F-12169-40-00	PAD, ADJUSTING (2.875)	16	UR
11	67F-12169-50-00	PAD, ADJUSTING (2.900)	16	UR
11	67F-12169-60-00	PAD, ADJUSTING (2.925)	16	UR
11	67F-12169-70-00	PAD, ADJUSTING (2.950)	16	UR
11	67F-12169-80-00	PAD, ADJUSTING (2.975)	16	UR
11	67F-12169-A0-00	PAD, ADJUSTING (3.000)	16	UR
11	67F-12169-B0-00	PAD, ADJUSTING (3.025)	16	UR
11	67F-12169-C0-00	PAD, ADJUSTING (3.050)	16	UR
11	67F-12169-D0-00	PAD, ADJUSTING (3.075)	16	UR
11	67F-12169-E0-00	PAD, ADJUSTING (3.100)	16	UR
11	67F-12169-F0-00	PAD, ADJUSTING (3.125)	16	UR
11	67F-12169-G0-00	PAD, ADJUSTING (3.150)	16	UR
11	67F-12169-H0-00	PAD, ADJUSTING (3.175)	16	UR
11	67F-12169-J0-00	PAD, ADJUSTING (3.200)	16	UR
11	67F-12169-K0-00	PAD, ADJUSTING (3.225)	16	UR
11	67F-12169-L0-00	PAD, ADJUSTING (3.250)	16	UR
11	67F-12169-M0-00	PAD, ADJUSTING (3.275)	16	UR

11	67F-12169-10-00	PAD, ADJUSTING (2.800)	16	UR
12	6D8-12171-00-00	CAMSHAFT 1	1	
13	67F-12181-00-00	CAMSHAFT 2	1	
14	93605-10108-00	.PIN, DOWEL	2	
15	67F-11537-00-00	GEAR, DRIVEN	2	
16	90119-10M06-00	BOLT, WITH WASHER	2	
17	67F-46241-00-00	BELT	1	
18	67F-11590-00-00	TENSIONER ASSY	1	
19	90506-16M39-00	SPRING, TENSION	1	
20	90445-15M03-00	HOSE (L23)	1	
21	67F-11595-00-00	PLATE, VALVE	1	
22	90119-10M72-00	BOLT, WITH WASHER	1	
23	6D8-11536-00-00	GEAR, DRIVE	1	
24	90170-40003-00	NUT	1	
25	90280-04008-00	KEY, WOODRUFF	1	
26	93102-38M59-00	.OIL SEAL	2	

F90TLR 0406 / INTAKE 1

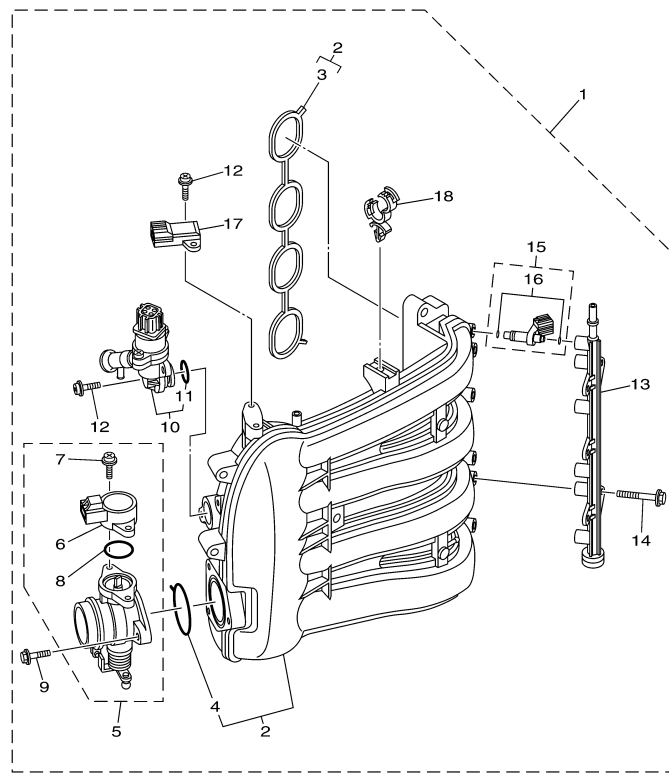

  
6D81100-D060

©2014 Yamaha Motor Corporation, U.S.A. All rights reserved.

## Part List

F90TLR 0406 / INTAKE 1

REF - NO	PART NUMBER	PART NAME	QUANTITY	REMARKS
1	6D8-14200-00-00	INTAKE ASSY	1	
2	6D8-13641-00-00	.MANIFOLD, INTAKE 1	1	
3	6D8-13645-00-00	..GASKET, MANIFOLD 1	1	
4	6D8-13557-00-00	..GASKET	1	
5	6D8-13750-00-00	.THROTTLE BODY ASSY	1	
6	6C5-85885-00-00	..THROTTLE SENSOR ASSY	1	
7	6C5-81145-00-00	..SCREW 1	2	
8	6C5-8182L-00-00	..O-RING 1	1	
9	6C5-14496-00-00	.BOLT	3	
10	6D8-13105-01-00	.CONTROL VALVE ASSY	1	
11	6C5-1319C-00-00	..O-RING	1	
12	6C5-81146-00-00	.SCREW 2	4	
13	6D8-13161-00-00	.PIPE, DELIVERY 1	1	
14	6C5-14446-00-00	.BOLT	2	
15	6D8-13761-00-00	.INJECTOR	4	
16	6C5-1410B-00-00	..PACKING KIT	1	
17	68F-83688-00-00	.SENSOR ASSY	1	
18	90464-18246-00	.CLAMP	1	

F90TLR 0406 / INTAKE 2

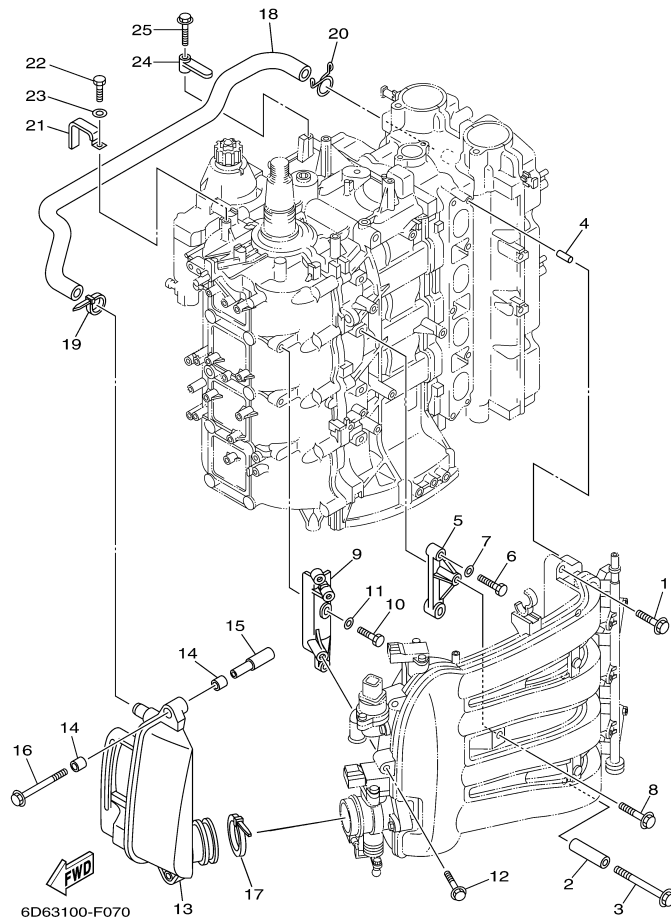

©2014 Yamaha Motor Corporation, U.S.A. All rights reserved.

## Part List

F90TLR 0406 / INTAKE 2

REF - NO	PART NUMBER	PART NAME	QUANTITY	REMARKS
1	90119-08069-00	BOLT, WITH WASHER	4	
2	90387-08033-00	COLLAR	1	
3	90119-08M03-00	BOLT, WITH WASHER	1	
4	91690-50014-00	PIN, SPRING	2	
5	6D8-14291-00-94	BRACKET 1	1	
6	97095-06030-00	BOLT	2	
7	92995-06600-00	WASHER	2	
8	90119-06087-00	BOLT, WITH WASHER	1	
9	6D8-14292-00-94	BRACKET 2	1	
10	97095-06020-00	BOLT	2	
11	92995-06600-00	WASHER	2	
12	90119-06087-00	BOLT, WITH WASHER	2	
13	6D8-14440-01-00	SILENCER ASSY, INTAKE	1	UR F90
14	90386-08001-00	BUSH	4	
15	90387-07013-00	COLLAR	2	
16	90119-06113-00	BOLT, WITH WASHER	2	
17	90464-76001-00	CLAMP	1	
18	6D8-15373-00-00	PIPE, BREATHER	1	
19	90465-11M59-00	CLAMP	1	
20	90467-20M15-00	CLIP	1	
21	90465-12M03-00	CLAMP	1	
22	97095-06012-00	BOLT	1	
23	92995-06600-00	WASHER	1	
24	6D8-82544-00-00	CLAMP	1	
25	95895-06025-00	BOLT, FLANGE	1	

F90TLR 0406 / INTAKE 3

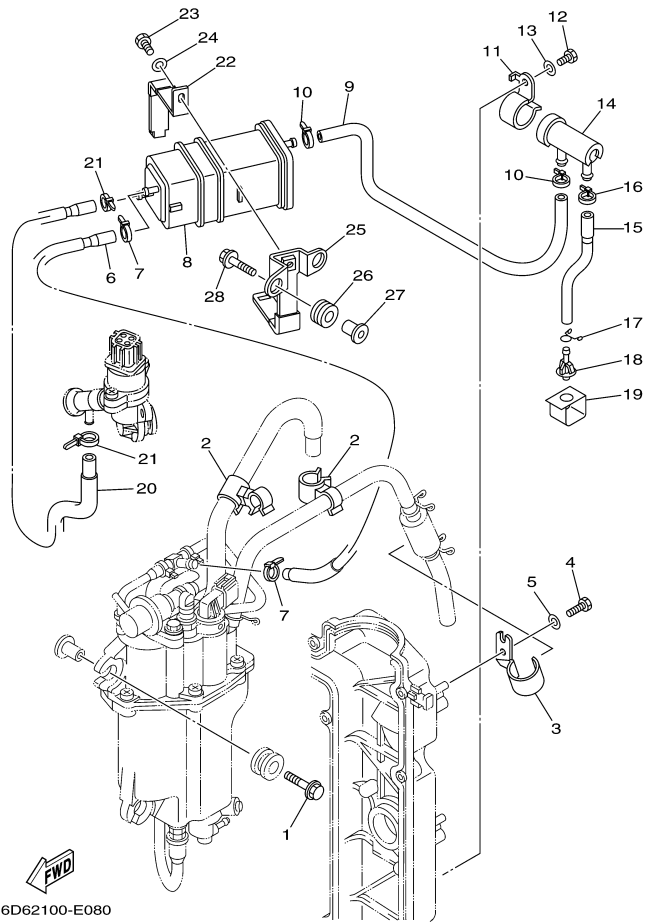

6D62100-E080

©2014 Yamaha Motor Corporation, U.S.A. All rights reserved.



## Part List

F90TLR 0406 / INTAKE 3

REF - NO	PART NUMBER	PART NAME	QUANTITY	REMARKS
1	90119-06M08-00	BOLT, WITH WASHER	3	
2	90464-15007-00	CLAMP	2	
3	6D8-13428-00-00	BRACKET, STRAINER 1	1	
4	97095-06012-00	BOLT	1	
5	92995-06600-00	WASHER	1	
6	6D8-24314-01-00	PIPE 4	1	
7	90465-11M10-00	CLAMP	2	
8	69J-24170-00-00	CANISTER ASSY	1	
9	6D8-24315-00-00	PIPE 5	1	
10	90465-11M10-00	CLAMP	2	
11	6D8-2417H-00-00	CLAMP 1	1	
12	97095-06010-00	BOLT	1	
13	92995-06600-00	WASHER	1	
14	69J-24502-00-00	FILTER, FUEL	1	
15	6D8-24316-00-00	PIPE 6	1	
16	90465-11M10-00	CLAMP	1	
17	90467-09M03-00	CLIP	1	
18	69J-44391-00-00	NIPPLE, HOSE	1	
19	6D8-2413X-00-00	PLATE	1	
20	6D8-24317-01-00	PIPE 7	1	
21	90465-11M10-00	CLAMP	2	
22	69J-2419A-00-00	HOLDER	1	
23	97095-06016-00	BOLT	1	
24	92995-06600-00	WASHER	1	
25	6D8-2134X-00-00	BRACKET, CANISTER	1	
26	90480-10M23-00	GROMMET	2	
27	90387-06M60-00	COLLAR	2	
28	90119-06M59-00	BOLT, WITH WASHER	2	

F90TLR 0406 / FUEL INJECTION PUMP 1

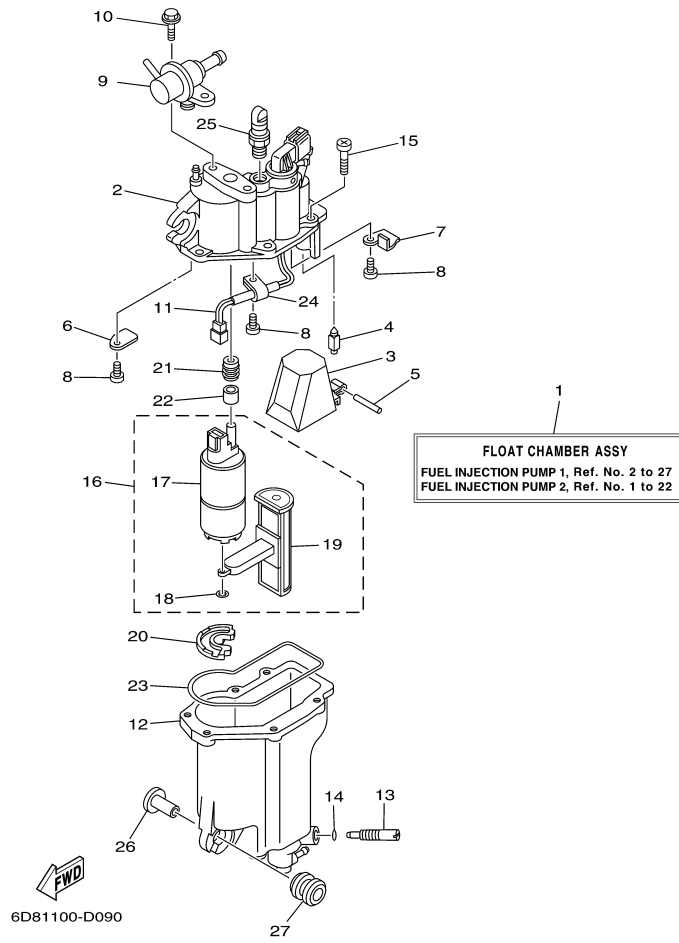

©2014 Yamaha Motor Corporation, U.S.A. All rights reserved.

## Part List

F90TLR 0406 / FUEL INJECTION PUMP 1

REF - NO	PART NUMBER	PART NAME	QUANTITY	REMARKS
1	6D8-14180-20-00	FLOAT CHAMBER ASSY	1	UR FOR 62P-1009564~ 61P-1024598~
1	6D8-14180-00-00	FLOAT CHAMBER ASSY	1	
2	6D8-14182-00-00	COVER, FLOAT CHAMBER	1	
3	6C5-14985-00-00	FLOAT	1	
4	6C5-14546-00-00	VALVE, NEEDLE	1	
5	6C5-14386-00-00	PIN, FLOAT	1	
6	6C5-2441R-00-00	PLATE, BAFFLE 1	1	
7	6C5-2441T-00-00	PLATE, BAFFLE 2	1	
8	6C5-24453-00-00	SCREW	3	
9	6C5-13906-00-00	REGULATOR, PRESSURE	1	
10	6C5-24592-00-00	BOLT	2	
11	6C5-87226-00-00	WIRE HARNESS ASSY	1	
12	6D8-14960-00-00	BODY ASSY	1	
13	6C5-14191-00-00	PLUG, DRAIN	1	
14	6C5-14397-00-00	O-RING	1	
15	6C5-14567-00-00	SCREW	6	
16	6C5-13910-00-00	FUEL PUMP ASSY	1	
17	6C5-13907-00-00	.FUEL PUMP COMP	1	
18	6C5-14127-00-00	.CLIP	1	
19	6C5-13915-00-00	.FILTER	1	
20	6C5-13593-00-00	DAMPER	1	
21	6C5-13781-00-00	DAMPER, PUMP	1	
22	6C5-13716-00-00	COLLAR	1	
23	6C5-14984-00-00	GASKET, FLOAT CHAMBER	1	
24	6C5-21337-00-00	CLAMP, CABLE	1	
25	6C5-14225-00-00	CAP	1	
26	90387-06M69-00	COLLAR	3	
27	90480-09M12-00	GROMMET	3	

F90TLR 0406 / FUEL INJECTION PUMP 2

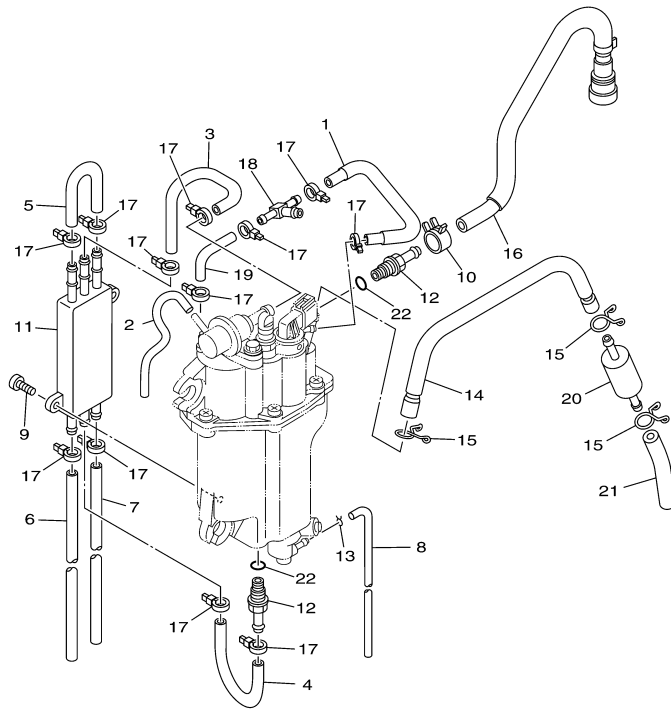

6D82100-E100

©2014 Yamaha Motor Corporation, U.S.A. All rights reserved.

## Part List

F90TLR 0406 / FUEL INJECTION PUMP 2

REF - NO	PART NUMBER	PART NAME	QUANTITY	REMARKS
1	6D8-13546-01-00	HOSE 2	1	
2	6D8-13542-01-00	HOSE, VACUUM SENSING 1	1	
3	6C5-24321-00-00	PIPE 10	1	
4	6C5-24322-00-00	PIPE 11	1	
5	6C5-24323-00-00	PIPE 12	1	
6	6D8-24324-01-00	PIPE 13	1	
7	6D8-42325-10-00	PIPE 14 (L430)	1	UR FOR 62P-1009564~ 61P-1024598~
7	6D8-24325-00-00	PIPE 14 (L500)	1	
8	6C5-14149-00-00	PIPE (L200)	1	
9	6C5-24444-00-00	SCREW	2	
10	6C5-13577-00-00	CLIP	1	
11	6C5-21841-00-00	COOLER	1	
12	6C5-14251-00-00	NIPPLE	2	
13	6C5-2411M-00-00	CLIP	1	
14	6D8-14148-00-00	PIPE	1	
15	6C5-24387-00-00	CLIP	3	
16	6D8-13974-00-00	PIPE, FUEL 4	1	
17	90465-11M10-00	CLAMP	12	
18	6C5-24379-00-00	PIPE, JOINT 4	1	
19	6C5-13545-00-00	HOSE 1	1	
20	6C5-24251-00-00	STRAINER 1	1	
21	6D8-2451B-00-00	HOSE, FUEL INLET	1	
22	6C5-13739-00-00	O-RING	2	

## Part Notes

F90TLR 0406 / FUEL INJECTION PUMP 2

PART NUMBER	NOTE TEXT
6C5-24251-00-00 	OEM: This part number is among the Top 100 Most Popular Marine Maintenance Parts as of March 2014.

©2014 Yamaha Motor Corporation, U.S.A. All rights reserved.

F90TLR 0406 / FUEL 1

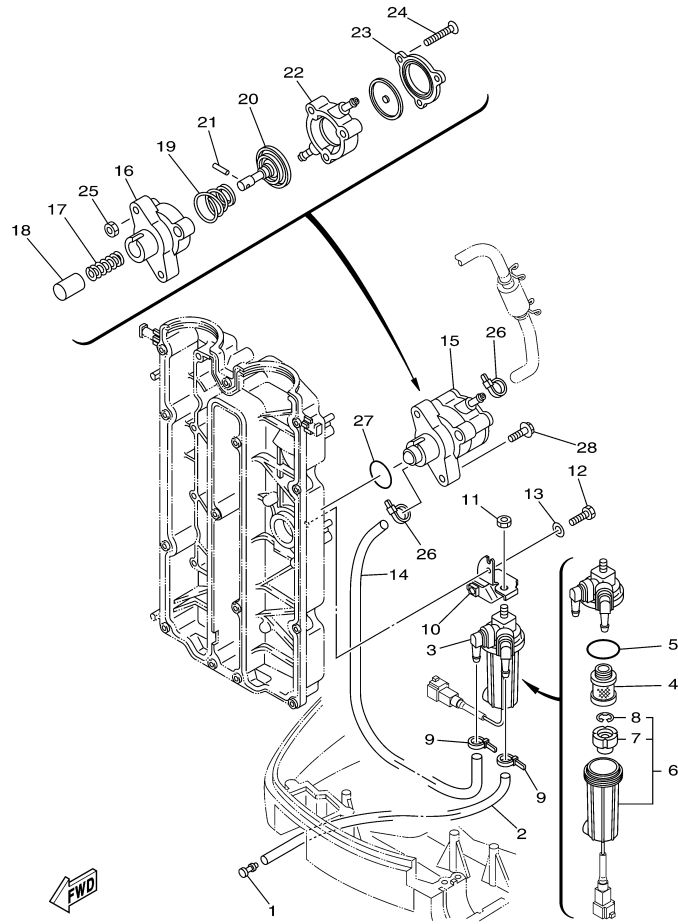

6D63110-F110

©2014 Yamaha Motor Corporation, U.S.A. All rights reserved.

## Part List

F90TLR 0406 / FUEL 1

REF - NO	PART NUMBER	PART NAME	QUANTITY	REMARKS
1	689-85547-00-00	DAMPER	1	
2	90445-13M37-00	HOSE (L2300)	1	
3	6D8-24560-00-00	FILTER ASSY	1	
4	6D8-WS24A-00-00	..ELEMENT, FILTER	1	
5	6D8-24564-00-00	.GASKET	1	
6	6D8-24562-00-00	.CUP, FILTER	1	
7	6D8-24469-00-00	..FLOAT, WATER LEVEL	1	
8	6D8-24519-00-00	..CLIP	1	
9	90465-11M10-00	CLAMP	2	
10	6D8-24566-00-00	BRACKET, FILTER	1	
11	95380-08600-00	NUT	1	
12	97095-06016-00	BOLT	1	
13	92995-06600-00	WASHER	1	
14	6D8-24311-00-00	PIPE, FUEL 1	1	
15	6D8-24410-00-00	FUEL PUMP ASSY	1	
16	68V-24412-00-00	.BODY 1	1	
17	68V-24454-00-00	.SPRING	1	
18	63P-13131-00-00	.PLUNGER	1	
19	68V-24423-00-00	.SPRING, DIAPHRAGM	1	
20	68V-24411-00-00	.DIAPHRAGM	1	
21	68V-24374-00-00	.PIN	1	
22	68V-24413-00-00	.BODY 2	1	
23	6D8-24414-00-00	.BODY 3	1	
24	68V-24444-00-00	.SCREW	3	
25	68V-24149-00-00	.NUT	3	
26	90465-11M10-00	CLAMP	2	
27	93210-30682-00	.O-RING	1	
28	90119-06M83-00	BOLT, WITH WASHER	2	

## Part Notes

F90TLR 0406 / FUEL 1

PART NUMBER	NOTE TEXT
6D8-WS24A-00-00 	OEM: This part number is among the Top 100 Most Popular Marine Maintenance Parts as of March 2014.

©2014 Yamaha Motor Corporation, U.S.A. All rights reserved.

F90TLR 0406 / FUEL 2

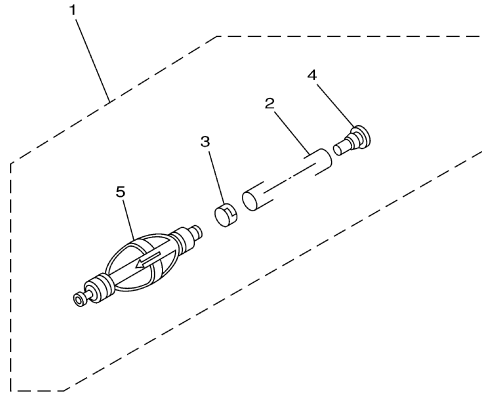

©2014 Yamaha Motor Corporation, U.S.A. All rights reserved.



## Part List

F90TLR 0406 / FUEL 2

REF - NO	PART NUMBER	PART NAME	QUANTITY	REMARKS
1	6Y2-24307-50-00	FUEL PIPE COMP. 2	1	AP
2	90445-13M01-00	.HOSE (L2050)	1	
3	6E5-24351-51-00	.BAND 1	1	
4	90480-06M19-00	.GROMMET	1	
5	6Y2-24360-60-00	.PRIMER PUMP ASSY	1	

F90TLR 0406 / GENERATOR

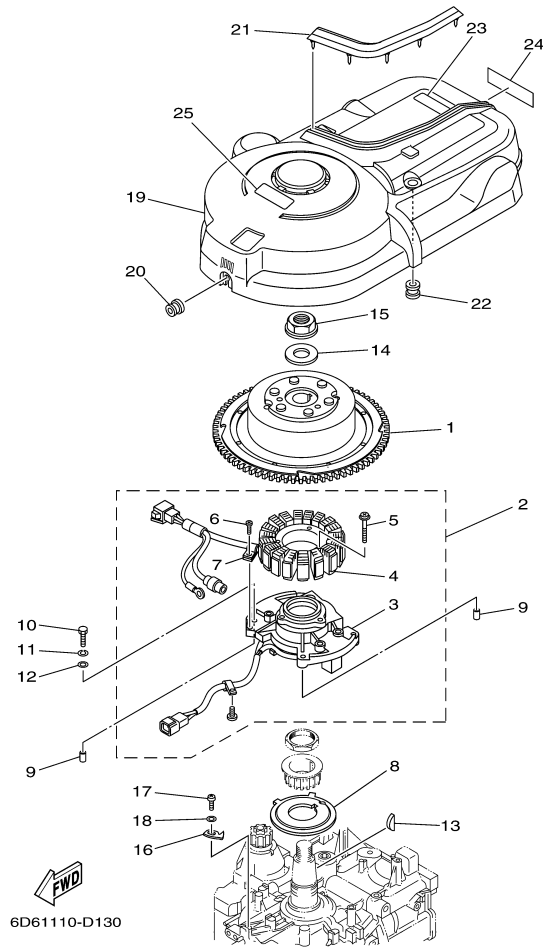

©2014 Yamaha Motor Corporation, U.S.A. All rights reserved.

Part List

F90TLR 0406 / GENERATOR

REF - NO	PART NUMBER	PART NAME	QUANTITY	REMARKS
1	6D8-81450-00-00	ROTOR ASSY	1	
2	6D8-81460-00-00	BASE ASSY	1	
3	6D8-85580-00-00	.COIL, PULSER	1	
4	6D8-81410-00-00	.STATOR ASSY	1	
5	63D-81345-20-00	.SCREW, WITH WASHER (M6X30)	3	
6	97607-04110-00	.SCREW, WITH WASHER	1	
7	445-81328-20-00	.CLAMP	1	
8	68V-81673-00-00	ROTOR	1	
9	99530-08012-00	PIN, DOWEL	2	
10	97095-06030-00	BOLT	4	
11	92995-06100-00	WASHER, SPRING	4	
12	92995-06600-00	WASHER	4	
13	90280-05015-00	KEY, WOODRUFF	1	
14	90201-24014-00	WASHER, PLATE	1	
15	90179-24002-00	NUT	1	
16	6D8-81332-00-00	PLATE, TIMING	1	
17	97885-06010-00	SCREW, PAN HEAD	1	
18	92995-06600-00	WASHER	1	
19	6D8-81337-00-00	COVER, FLYWHEEL	1	
20	90480-12072-00	GROMMET	1	
21	6D8-85547-00-00	DAMPER	1	
22	663-82317-01-00	DAMPER, IGNITION COIL	2	
23	67F-12138-40-00	MARK, CAUTION	1	
24	68V-13437-41-00	MARK, CAUTION	1	
25	6A1-83625-41-00	MARK 5	1	

Part Notes

F90TLR 0406 / GENERATOR

PART NUMBER	NOTE TEXT
90480-12072-00 	OEM: GROMMET used on F115TLR and F/LF115TXR 0410 Production and Earlier

©2014 Yamaha Motor Corporation, U.S.A. All rights reserved.

F90TLR 0406 / ELECTRICAL 1

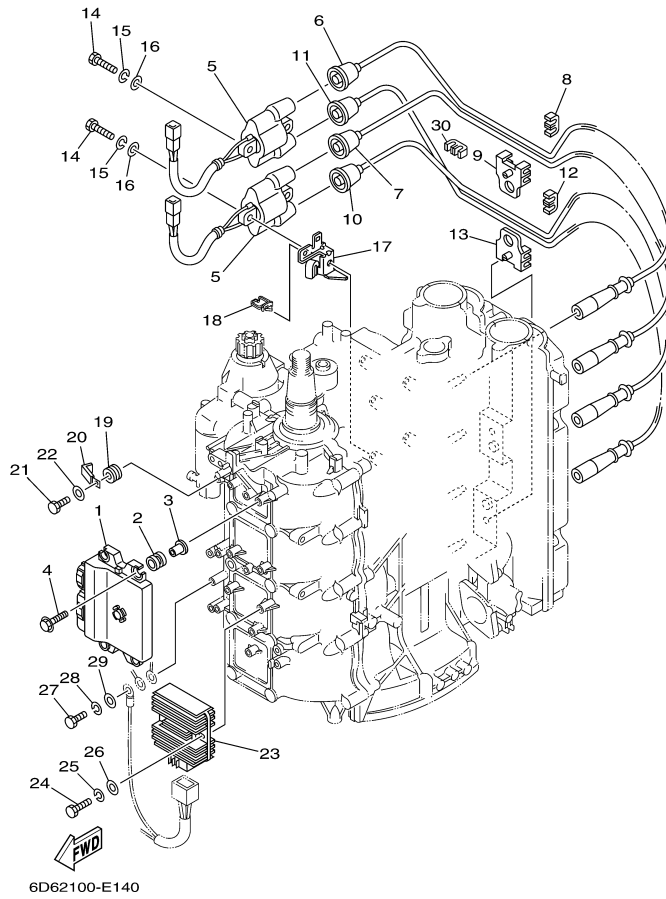

©2014 Yamaha Motor Corporation, U.S.A. All rights reserved.

## Part List

F90TLR 0406 / ELECTRICAL 1

REF - NO	PART NUMBER	PART NAME	QUANTITY	REMARKS
1	6D8-8591A-11-00	ENGINE CONTROL UNIT ASSY	1	UR F90
2	68V-82317-00-00	DAMPER, IGNITION COIL	4	
3	90387-06119-00	COLLAR	4	
4	90119-06M59-00	BOLT, WITH WASHER	4	
5	63P-82310-01-00	IGNITION COIL ASSY	2	
6	67F-82341-00-00	CORD, HIGH TENSION 1	1	#1
7	67F-82342-00-00	CORD, HIGH TENSION 2	1	#2
8	67F-82361-00-00	CLAMP, CORD	1	
9	67F-82362-00-00	CLAMP, CORD 2	1	
10	67F-82343-00-00	CORD, HIGH TENSION 3	1	#3
11	67F-82344-00-00	CORD, HIGH TENSION 4	1	#4
12	67F-82361-00-00	CLAMP, CORD	1	
13	67F-82362-00-00	CLAMP, CORD 2	1	
14	97095-06025-00	BOLT	4	
15	92995-06100-00	WASHER, SPRING	4	
16	92995-06600-00	WASHER	4	
17	6D8-82388-01-00	PLATE	2	
18	90464-08004-00	CLAMP	2	
19	90480-14329-00	GROMMET	1	
20	90465-08M23-00	CLAMP	1	
21	97095-06014-00	BOLT	1	
22	92995-06600-00	WASHER	1	
23	6D3-81960-00-00	RECTIFIER & REGULATOR ASSY	1	
24	97095-06025-00	BOLT	2	
25	92995-06100-00	WASHER, SPRING	2	
26	92995-06600-00	WASHER	2	
27	97095-06016-00	BOLT	1	
28	92995-06100-00	WASHER, SPRING	1	
29	92995-06600-00	WASHER	1	
30	67F-82361-00-00	CLAMP, CORD	1	UR FOR 62P-1009564~ 61P-1024598~

F90TLR 0406 / ELECTRICAL 2

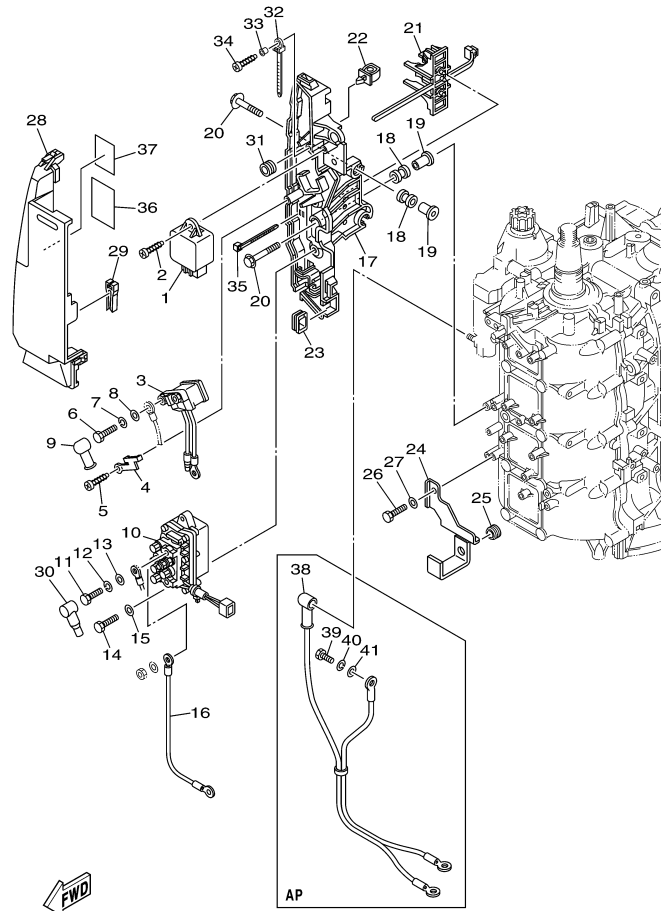

6D62110-E150

## Part List

F90TLR 0406 / ELECTRICAL 2

REF - NO	PART NUMBER	PART NAME	QUANTITY	REMARKS
1	60E-81950-00-00	RELAY ASSY	1	
2	97780-60625-00	SCREW, TAPPING	1	
3	68V-8194A-00-00	RELAY	1	
4	68V-81953-00-00	STAY, RELAY	1	
5	97780-60620-00	SCREW, TAPPING	1	
6	97095-06010-00	BOLT	2	
7	92995-06100-00	WASHER, SPRING	2	
8	92995-06600-00	WASHER	2	
9	6G5-82119-00-00	COVER, LEAD WIRE	2	
10	63P-81950-00-00	RELAY ASSY	1	
11	97095-06010-00	BOLT	2	
12	92995-06100-00	WASHER, SPRING	2	
13	92995-06600-00	WASHER	2	
14	97013-06020-00	BOLT	2	
15	92903-06600-00	WASHER, PLATE	2	
16	61A-81949-00-00	WIRE, LEAD	1	
17	68V-81948-02-00	BRACKET	1	
18	6A0-82317-00-00	DAMPER, IGNITION COIL	5	
19	90387-06119-00	COLLAR	5	
20	90119-06M59-00	BOLT, WITH WASHER	5	
21	68V-82594-00-00	CLAMP	1	
22	90464-12M58-00	CLAMP	1	
23	6D8-81518-00-00	GROMMET	1	
24	6D8-81528-00-00	CLAMP 1	1	
25	90480-13M24-00	GROMMET	1	
26	97095-06014-00	BOLT	1	
27	92995-06600-00	WASHER	1	
28	68V-81942-03-00	COVER	1	
29	67F-2812A-00-00	.PULLER, FUSE	1	
30	682-82119-01-00	COVER, LEAD WIRE	2	
31	6A0-82317-00-00	DAMPER, IGNITION COIL	1	
32	90465-12M53-00	CLAMP	1	
33	90387-06M05-00	COLLAR	1	
34	97780-60625-00	SCREW, TAPPING	1	
35	90465-13M18-00	CLAMP	2	
36	68V-81919-00-00	GRAPHIC, REGULATOR	1	
37	6D8-81919-00-00	GRAPHIC, REGULATOR	1	
38	68V-82105-00-00	BATTERY CABLE	1	AP
39	97013-06020-00	BOLT	1	AP
40	92903-06100-00	WASHER, SPRING	1	AP
41	92903-06600-00	WASHER, PLATE	1	AP

F90TLR 0406 / ELECTRICAL 3

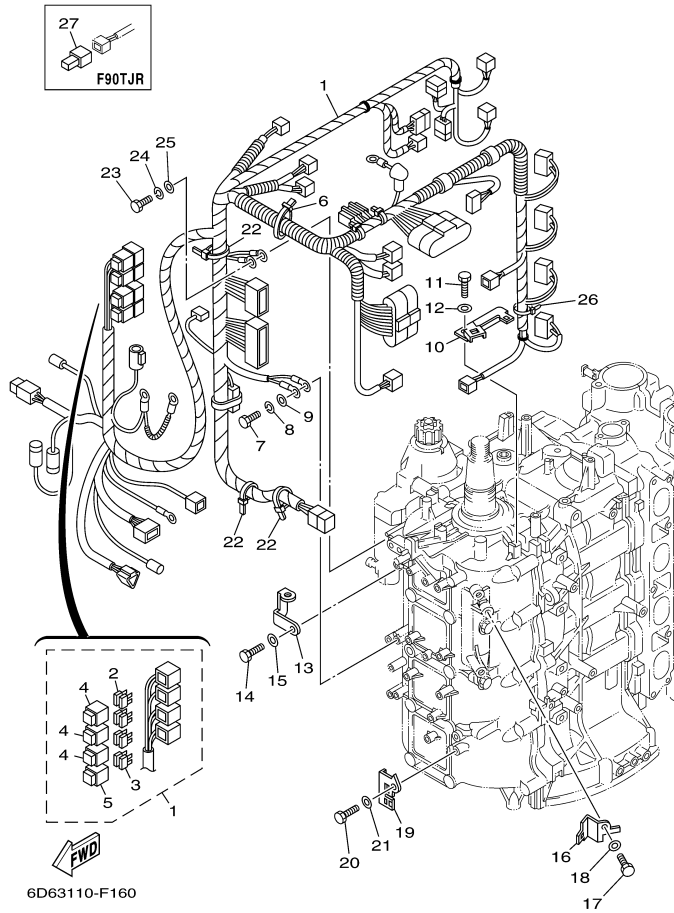

©2014 Yamaha Motor Corporation, U.S.A. All rights reserved.



## Part List

F90TLR 0406 / ELECTRICAL 3

REF - NO	PART NUMBER	PART NAME	QUANTITY	REMARKS
1	6D8-82590-30-00	WIRE HARNESS ASSY	1	
2	67F-82151-00-00	.FUSE (20A)	6	
3	67F-82151-10-00	.FUSE (30A)	2	
4	67F-8215B-10-00	.CAP (YELLOW)	3	
5	67F-8215B-20-00	.CAP (GREEN)	1	
6	90464-76001-00	CLAMP	1	
7	97095-06016-00	BOLT	1	
8	92995-06100-00	WASHER, SPRING	1	
9	92995-06600-00	WASHER	1	
10	6D8-82588-00-00	PLATE	1	
11	97095-06012-00	BOLT	1	
12	92995-06600-00	WASHER	1	
13	6D8-82581-00-00	STAY, CORD CLAMP	1	
14	97095-06014-00	BOLT	1	
15	92995-06600-00	WASHER	1	
16	6D8-82389-00-00	PLATE 2	1	
17	97095-06012-00	BOLT	1	
18	92995-06600-00	WASHER	1	
19	6D8-82398-00-00	PLATE 3	1	
20	97095-06012-00	BOLT	1	
21	92995-06600-00	WASHER	1	
22	90465-13M18-00	CLAMP	3	
23	97095-06016-00	BOLT	1	
24	92995-06100-00	WASHER, SPRING	1	
25	92995-06600-00	WASHER	1	
26	90465-13M11-00	CLAMP	1	
27	68V-82582-10-00	COVER, WIRE HARNESS	1	F90TJR

F90TLR 0406 / ELECTRICAL 4

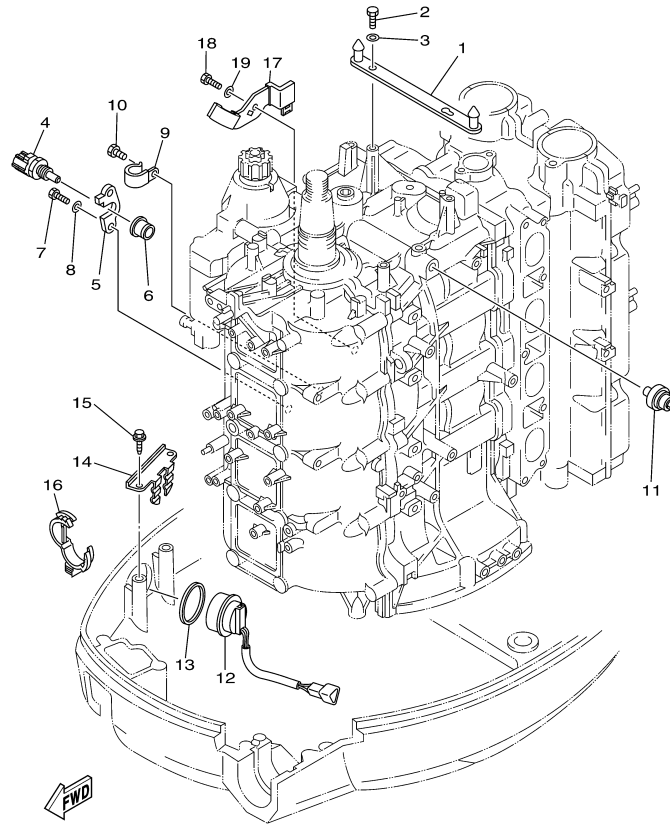

6D62100-E170

©2014 Yamaha Motor Corporation, U.S.A. All rights reserved.

## Part List

F90TLR 0406 / ELECTRICAL 4

REF - NO	PART NUMBER	PART NAME	QUANTITY	REMARKS
1	6D8-8132G-00-00	PLATE	1	
2	97095-06016-00	BOLT	2	
3	92995-06600-00	WASHER	2	
4	67F-85790-00-00	THERMOSENSOR ASSY	1	
5	67F-85757-00-00	RETAINER	1	
6	68V-85753-00-00	.GASKET, SENDER UNIT	1	
7	97095-06016-00	BOLT	2	
8	92995-06600-00	WASHER	2	
9	90465-06M86-00	.CLAMP	1	
10	97095-06010-00	BOLT	1	
11	68V-82504-00-00	OIL PRESSURE SWITCH ASSY	1	
12	63D-82563-10-00	TRIM & TILT SWITCH ASSY	1	
13	6E5-82587-00-00	GASKET	1	
14	67F-83614-00-00	BRACKET	1	
15	90109-06M86-00	BOLT	2	
16	90464-30003-00	CLAMP	2	
17	6D8-8252H-00-00	PLATE, HOLDER	1	
18	97095-06012-00	BOLT	1	
19	92995-06600-00	WASHER	1	

F90TLR 0406 / STARTING MOTOR

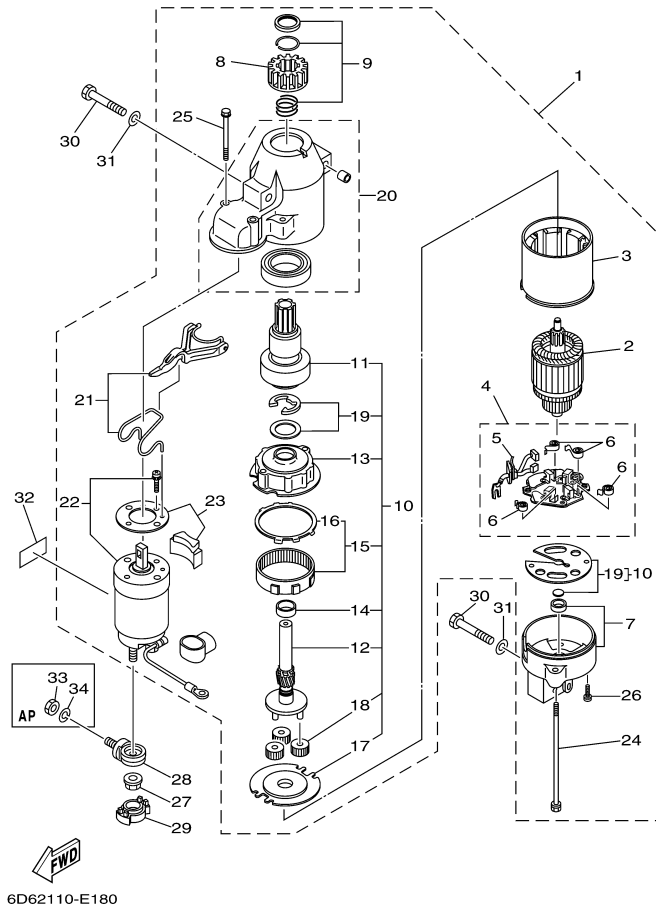

©2014 Yamaha Motor Corporation, U.S.A. All rights reserved.

## Part List

F90TLR 0406 / STARTING MOTOR

REF - NO	PART NUMBER	PART NAME	QUANTITY	REMARKS
1	68V-81800-01-00	STARTING MOTOR ASSY	1	
2	67F-81850-00-00	.ARMATURE ASSY	1	
3	67F-81810-00-00	.STATOR ASSY	1	
4	68F-81840-00-00	.BRUSH HOLDER ASSY	1	
5	67F-81801-00-00	..BRUSH SET	1	
6	67F-81813-00-00	..SPRING, BRUSH	4	
7	68F-81820-00-00	.REAR BRACKET ASSY	1	
8	67F-81808-00-00	.PINION ASSY	1	
9	67F-81857-00-00	.PINION STOPPER SET	1	
10	67F-81807-00-00	.GEAR ASSY, STARTING MOTOR	1	
11	67F-81832-00-00	..CLUTCH, OVER RUN	1	
12	67F-81836-00-00	..SHAFT, PINION	1	
13	67F-81821-00-00	..BRACKET, CENTER 1	1	
14	67F-81841-00-00	..BEARING	1	
15	67F-81891-00-00	..GEAR, RING	1	
16	67F-8183R-00-00	...GASKET	1	
17	67F-81830-00-00	..BRACKET, CENTER 2	1	
18	60V-8183T-00-00	..GEAR, IDLER	3	
19	67F-81809-00-00	..WASHER KIT	1	
20	67F-81842-00-00	.COVER	1	
21	67F-81839-00-00	.LEVER ASSY	1	
22	68V-81941-01-00	.STARTER RELAY ASSY	1	
23	67F-81869-00-00	.COVER, DUST	1	
24	6K7-81826-10-00	.BOLT	2	
25	67F-81828-00-00	.SCREW 2	2	
26	67F-81846-00-00	.SCREW	2	
27	90179-08003-00	NUT	1	
28	60V-81925-00-00	TERMINAL	1	
29	68F-82582-00-00	COVER, WIRE HARNESS	1	
30	97013-08045-00	BOLT	3	
31	92903-08600-00	WASHER, PLATE	3	
32	67F-83627-01-00	LABEL, CAUTION 7	1	
33	95333-08600-00	NUT	1	AP
34	92903-08100-00	WASHER, SPRING	1	AP

F90TLR 0406 / BOTTOM COWLING

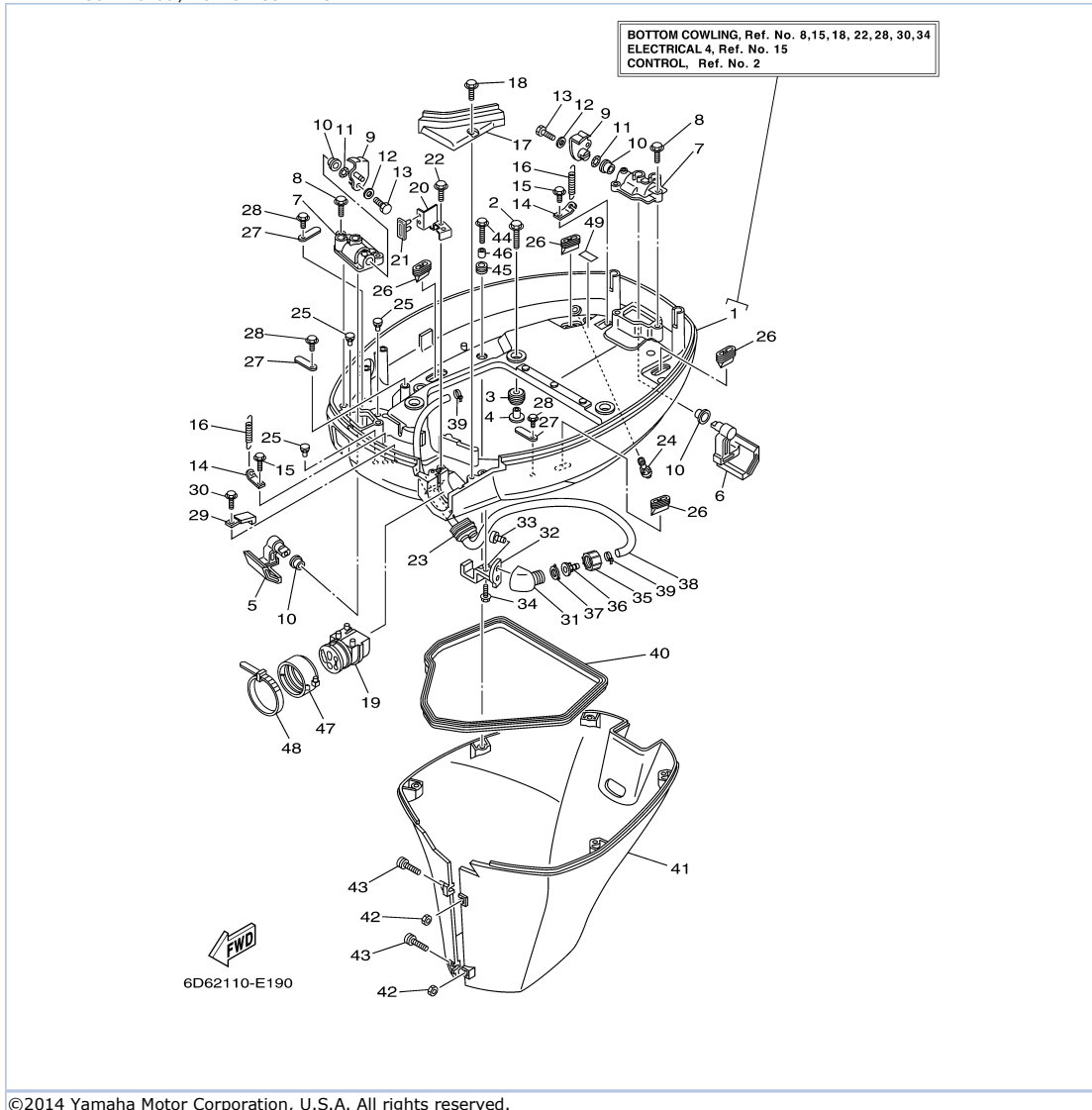

## Part List

F90TLR 0406 / BOTTOM COWLING

REF - NO	PART NUMBER	PART NAME	QUANTITY	REMARKS
1	6D8-42710-00-4D	BOTTOM COWLING ASSY	1	
2	90119-08M22-00	BOLT, WITH WASHER	4	
3	90480-22M15-00	GROMMET	4	
4	90387-08M37-00	COLLAR	4	
5	67F-42815-00-4D	LEVER, CLAMP	1	
6	67F-42816-00-4D	LEVER, CLAMP	1	
7	67F-42828-00-5B	PLATE, CLAMP	2	
8	90109-06M82-00	BOLT	4	
9	68V-42818-01-00	LEVER, CLAMP	2	
10	90386-15M73-00	BUSH	4	
11	90206-15M18-00	WASHER, WAVE	2	
12	90201-06068-00	WASHER, PLATE	2	
13	97095-06016-00	BOLT	2	
14	64D-43144-00-00	HOOK, SPRING	2	
15	90109-06M86-00	BOLT	2	
16	90506-16M34-00	SPRING, TENSION	2	
17	67F-42738-00-5B	PLATE, FITTING	1	
18	90109-06M96-00	BOLT	2	
19	68V-42725-00-00	GROMMET	1	
20	6D8-42756-00-00	STAY, CLAMP	1	
21	6D8-42717-00-00	RUBBER, SEAL 2	1	
22	90109-06M86-00	BOLT	1	
23	6H1-42726-21-00	GROMMET	1	
24	69D-44391-00-00	NIPPLE, HOSE	1	
24	6H3-44391-01-00	NIPPLE, HOSE	1	UR FOR 62P-1009564~ 61P-1024598~
25	6H4-42748-00-00	GROMMET	3	
26	67F-42717-00-00	RUBBER, SEAL 2	4	
27	6E5-82588-00-00	PLATE	3	
28	90109-06M81-00	BOLT	3	
29	90465-08M23-00	CLAMP	1	
30	90109-06M86-00	BOLT	1	
31	68T-12572-00-00	ADAPTER	1	FLUSHING KIT
32	67F-12535-00-00	PLATE	1	FLUSHING KIT
33	90167-06002-00	SCREW, TAPPING	2	FLUSHING KIT
34	90109-06M86-00	BOLT	1	FLUSHING KIT
35	6R3-12581-00-00	JOINT, HOSE 1	1	FLUSHING KIT
36	6R3-12582-00-00	JOINT, HOSE 2	1	FLUSHING KIT
37	6R3-12583-00-00	GASKET, HOSE JOINT	1	FLUSHING KIT
38	67F-24312-00-00	PIPE 2	1	FLUSHING KIT
39	90465-11M10-00	CLAMP	2	FLUSHING KIT
40	61A-42716-00-00	RUBBER, SEAL 1	1	
41	67F-42741-01-8D	APRON	1	
42	95380-06600-00	NUT, HEXAGON	2	
43	90159-06M28-00	SCREW, WITH WASHER	2	
44	90109-06M80-00	.BOLT	5	
45	90480-13M24-00	GROMMET	5	
46	90387-06M43-00	COLLAR	5	
47	68F-42753-00-00	FASTNER	1	AP
48	90464-20258-00	CLAMP	1	AP
49	67F-82377-00-00	LABEL	1	

F90TLR 0406 / CONTROL

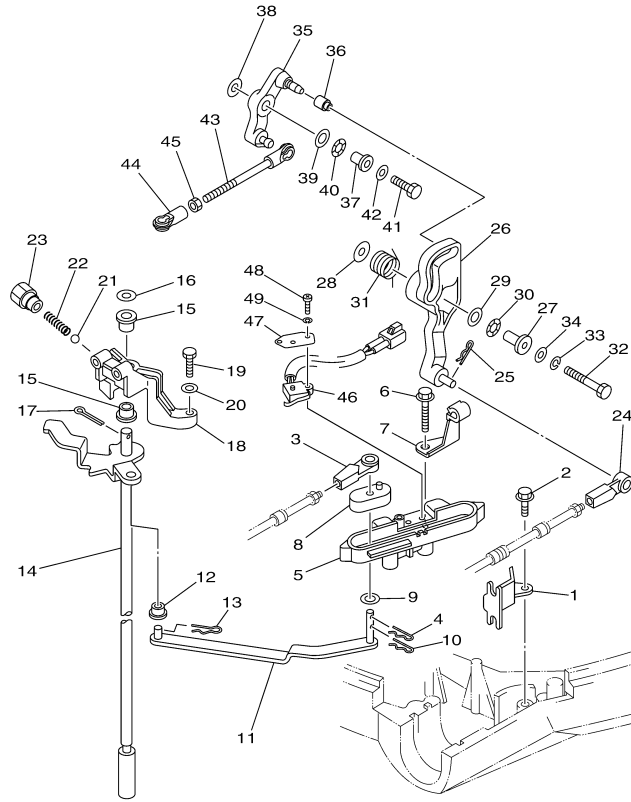

6D81100-D230

©2014 Yamaha Motor Corporation, U.S.A. All rights reserved.





Part List

F90TLR 0406 / CONTROL

REF - NO	PART NUMBER	PART NAME	QUANTITY	REMARKS
1	67F-48538-00-00	CLAMP, CABLE 1	1	
2	90109-06M86-00	BOLT	1	
3	663-48344-00-00	.CABLE END, REMOTE CONTROL	1	
4	90468-18008-00	CLIP	1	
5	6D8-44117-00-00	BRACKET	1	
6	97595-06550-00	BOLT, WITH WASHER	2	
7	90462-10027-00	CLAMP	1	
8	68V-44122-01-00	BUSHING, SHIFT ROD LEVER	1	
9	90202-07M07-00	WASHER, PLATE	1	
10	90468-18008-00	CLIP	1	
11	67F-44121-00-00	LEVER, SHIFT ROD	1	
12	90386-06M12-00	BUSH	1	
13	90468-18008-00	CLIP	1	
14	67F-44120-30-00	HANDLE GEAR SHIFT ASSY	1	UR X (26.1")
14	67F-44120-10-00	HANDLE GEAR SHIFT ASSY	1	UR L (21.1")
15	90386-90M90-00	BUSH	2	
16	90201-09M02-00	WASHER, PLATE	1	
17	91490-20015-00	PIN. COTTER	1	
18	67F-44118-00-00	BRACKET	1	
19	97075-06025-00	BOLT	2	
20	92995-06600-00	WASHER	2	
21	93501-04M02-00	BALL	1	
22	90501-12082-00	SPRING, COMPRESSION	1	
23	648-42715-00-00	BUSHING	1	
24	663-48344-00-00	.CABLE END, REMOTE CONTROL	1	
25	90468-18008-00	CLIP	1	
26	6D8-42154-00-00	LEVER, THROTTLE CONTROL	1	
27	90387-06M21-00	COLLAR	1	
28	90201-06M62-00	WASHER, PLATE	1	
29	90201-10M02-00	WASHER, PLATE	1	
30	90206-10M04-00	WASHER, WAVE	1	
31	67F-44135-00-00	SPRING	1	
32	97095-06035-00	BOLT	1	
33	92995-06100-00	WASHER, SPRING	1	
34	92995-06600-00	WASHER	1	
35	6D8-42157-00-00	LEVER, THROTTLE	1	
36	68V-42171-00-00	BUSHING	1	
37	90387-06013-00	COLLAR	1	
38	90201-06M31-00	.WASHER, PLATE	1	
39	90201-10M02-00	WASHER, PLATE	1	
40	90206-10M04-00	WASHER, WAVE	1	
41	97095-06025-00	BOLT	1	
42	92995-06600-00	WASHER	1	
43	6D8-41237-00-00	JOINT, LINK	1	
44	682-41237-00-00	JOINT, LINK	1	
45	95380-05600-00	NUT	1	
46	60V-8259F-00-00	SWITCH ASSY	1	EXCEPT F90TJR
47	61A-82588-01-00	PLATE	1	EXCEPT F90TJR
48	97885-04016-00	SCREW, PAN HEAD	2	EXCEPT F90TJR
49	92995-04100-00	WASHER	2	EXCEPT F90TJR

Part Notes

F90TLR 0406 / CONTROL

PART NUMBER	NOTE TEXT
90468-18008-00 	OEM: This part number is among the Top 100 Most Popular Marine Maintenance Parts as of March 2014.
90468-18008-00 	OEM: This part number is among the Top 100 Most Popular Marine Maintenance Parts as of March 2014.
90468-18008-00 	OEM: This part number is among the Top 100 Most Popular Marine Maintenance Parts as of March 2014.

90468-18008-00



OEM: This part number is among the Top 100 Most Popular Marine Maintenance Parts as of March 2014.

©2014 Yamaha Motor Corporation, U.S.A. All rights reserved.

F90TLR 0406 / BRACKET 1

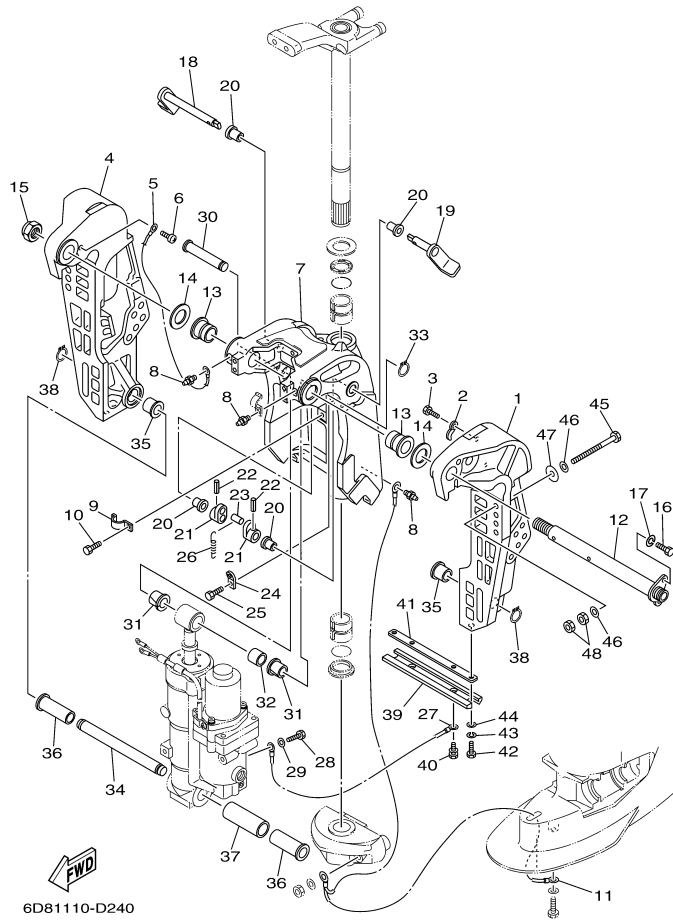

6D81110-D240

©2014 Yamaha Motor Corporation, U.S.A. All rights reserved.

## Part List

F90TLR 0406 / BRACKET 1

REF - NO	PART NUMBER	PART NAME	QUANTITY	REMARKS
1	67F-43111-00-4D	BRACKET, CLAMP	1	
2	90465-10M77-00	CLAMP	2	
3	97095-06010-00	BOLT	2	
4	67F-43112-00-4D	BRACKET, CLAMP 2	1	
5	6E5-82148-00-00	WIRE, LEAD 4	1	
6	97880-06012-00	SCREW, PAN HEAD	1	
7	6D8-43311-00-4D	BRACKET, SWIVEL 1	1	
8	93700-06M03-00	NIPPLE, GREASE	3	
9	90465-08M63-00	CLAMP	1	
10	97095-06010-00	BOLT	1	
11	67F-82127-00-00	WIRE, LEAD 2	1	
12	64E-43131-01-00	BOLT, CLAMP BRACKET	1	
13	90386-25M31-00	BUSH	2	
14	90201-26M59-00	WASHER, PLATE	2	
15	90185-22M11-00	NUT, SELF-LOCKING	1	
16	97095-08020-00	BOLT	1	
17	92995-08100-00	WASHER	1	
18	6D8-43181-00-00	LEVER, TILT STOP 1	1	
19	6D8-43185-00-00	LEVER, TILT STOP 2	1	
20	90386-10M16-00	BUSH	4	
21	6G5-43148-00-00	COLLAR, DISTANCE	2	
22	91690-30020-00	PIN, SPRING	2	
23	90249-06M19-00	PIN	1	
24	66T-43144-00-00	HOOK, SPRING	1	
25	97095-06010-00	BOLT	1	
26	90506-14M24-00	SPRING, TENSION	1	
27	6D8-82148-00-00	WIRE, LEAD 4	1	
28	97095-06010-00	BOLT	1	
29	92995-06600-00	WASHER	1	
30	6D8-43126-00-00	PIN, UPPER SHOCK MOUNT	1	
31	90386-18M35-00	BUSH	2	
32	90386-18001-00	BUSH	1	
33	93410-18M05-00	CIRCLIP	1	
34	67F-43818-00-00	PIN, LOWER SHOCK MOUNT	1	
35	90387-18M01-00	COLLAR	2	
36	90386-18MA0-00	BUSH	2	
37	90387-22M01-00	COLLAR	1	
38	93410-18M05-00	CIRCLIP	2	
39	6H1-45251-03-00	ANODE	1	
40	90119-06M81-00	BOLT, WITH WASHER	2	
41	6H1-44526-00-00	PLATE	1	
42	97095-06016-00	BOLT	2	
43	92995-06100-00	WASHER, SPRING	2	
44	92995-06600-00	WASHER	2	
45	90101-12M03-00	BOLT (L:115MM)	4	
46	90201-13M01-00	WASHER, PLATE	8	
47	90201-12M05-00	WASHER, PLATE	4	
48	95380-12600-00	NUT	8	

F90TLR 0406 / BRACKET 2

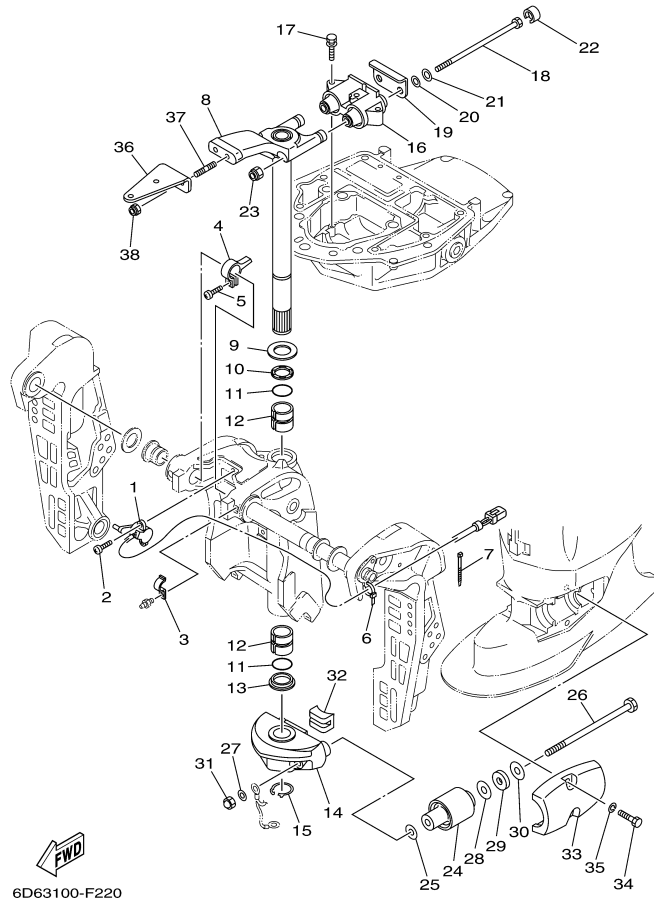

©2014 Yamaha Motor Corporation, U.S.A. All rights reserved.

## Part List

F90TLR 0406 / BRACKET 2

REF - NO	PART NUMBER	PART NAME	QUANTITY	REMARKS
1	67H-83672-00-00	TRIM SENDER	1	
2	97885-06016-00	SCREW, PAN HEAD	2	
3	90465-08M63-00	CLAMP	1	
4	64E-43139-02-00	CAM, TRIM SENDER	1	
5	97780-60525-00	SCREW, TAPPING	1	
6	90465-11M10-00	CLAMP	1	
7	90465-11M10-00	CLAMP	3	
8	67F-42510-11-4D	STEERING BRACKET ASSY	1	
9	90201-30M00-00	WASHER, PLATE	1	
10	90386-30M78-00	BUSH	1	
11	93210-29M94-00	O-RING	2	
12	90386-30M77-00	BUSH	2	
13	90386-30M60-00	BUSH	1	
14	67F-44551-00-4D	HOUSING, LOWER MOUNT RUBBER	1	
15	93410-28M06-00	CIRCLIP	1	
16	67F-44514-00-94	MOUNT DAMPER, UPPER SIDE	1	
17	90119-08091-00	BOLT, WITH WASHER	3	
18	90109-12007-00	BOLT	2	
19	67F-44526-00-00	PLATE	1	
20	90201-12M16-00	WASHER, PLATE	2	
21	90201-13M01-00	WASHER, PLATE	2	
22	67F-44533-00-00	DAMPER, UPPER MOUNT RUBBER	2	
23	95780-12300-00	NUT, FLANGE	2	
24	67F-44555-00-94	MOUNT DAMPER, LOWER SIDE	2	
25	90201-13M03-00	WASHER, PLATE	2	
26	90109-12012-00	BOLT	2	
27	90201-12M16-00	WASHER, PLATE	2	
28	90201-24M02-00	WASHER, PLATE	2	
29	90202-25M04-00	WASHER, PLATE	2	
30	90201-13M19-00	WASHER, PLATE	2	
31	95380-12800-00	NUT, CROWN	2	
32	67F-44575-00-00	DAMPER, LOWER MOUNT RUBBER	1	
33	67F-44553-00-4D	COVER, LOWER MOUNT	2	
34	97075-10040-00	BOLT	4	
35	92995-10100-00	WASHER	4	
36	67F-48511-00-4D	HOOK, STEERING	1	
37	90116-10175-00	BOLT, STUD	2	
38	90185-10051-00	NUT, SELF-LOCKING	2	

F90TLR 0406 / OPTIONAL PARTS

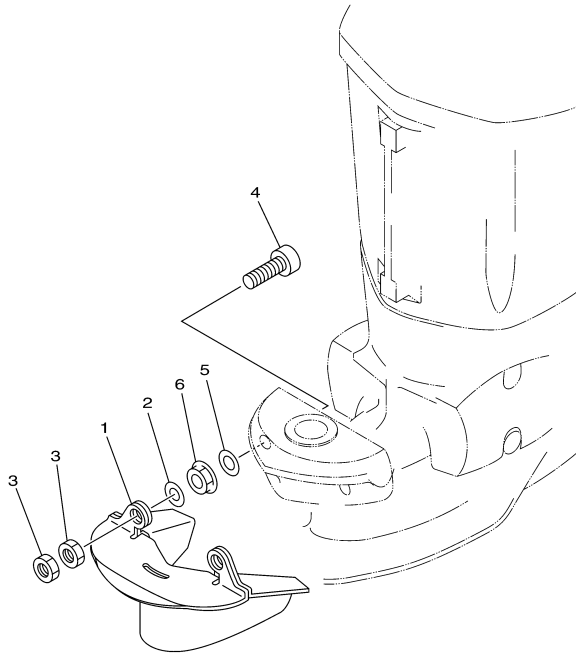

6D62100-E230

©2014 Yamaha Motor Corporation, U.S.A. All rights reserved.

## Part List

F90TLR 0406 / OPTIONAL PARTS

REF - NO	PART NUMBER	PART NAME	QUANTITY	REMARKS
1	67F-45180-00-4D	PLATE, SPLASH	1	AP
2	90201-12M01-00	WASHER, PLATE	2	AP
3	95380-12700-00	NUT	4	AP
4	90110-12M00-00	BOLT, HEXAGON SOCKET HEAD	2	AP
5	90201-12M16-00	WASHER, PLATE	2	AP
6	95780-12300-00	NUT, FLANGE	2	AP



F90TLR 0406 / POWER TRIM TILT ASSY 1

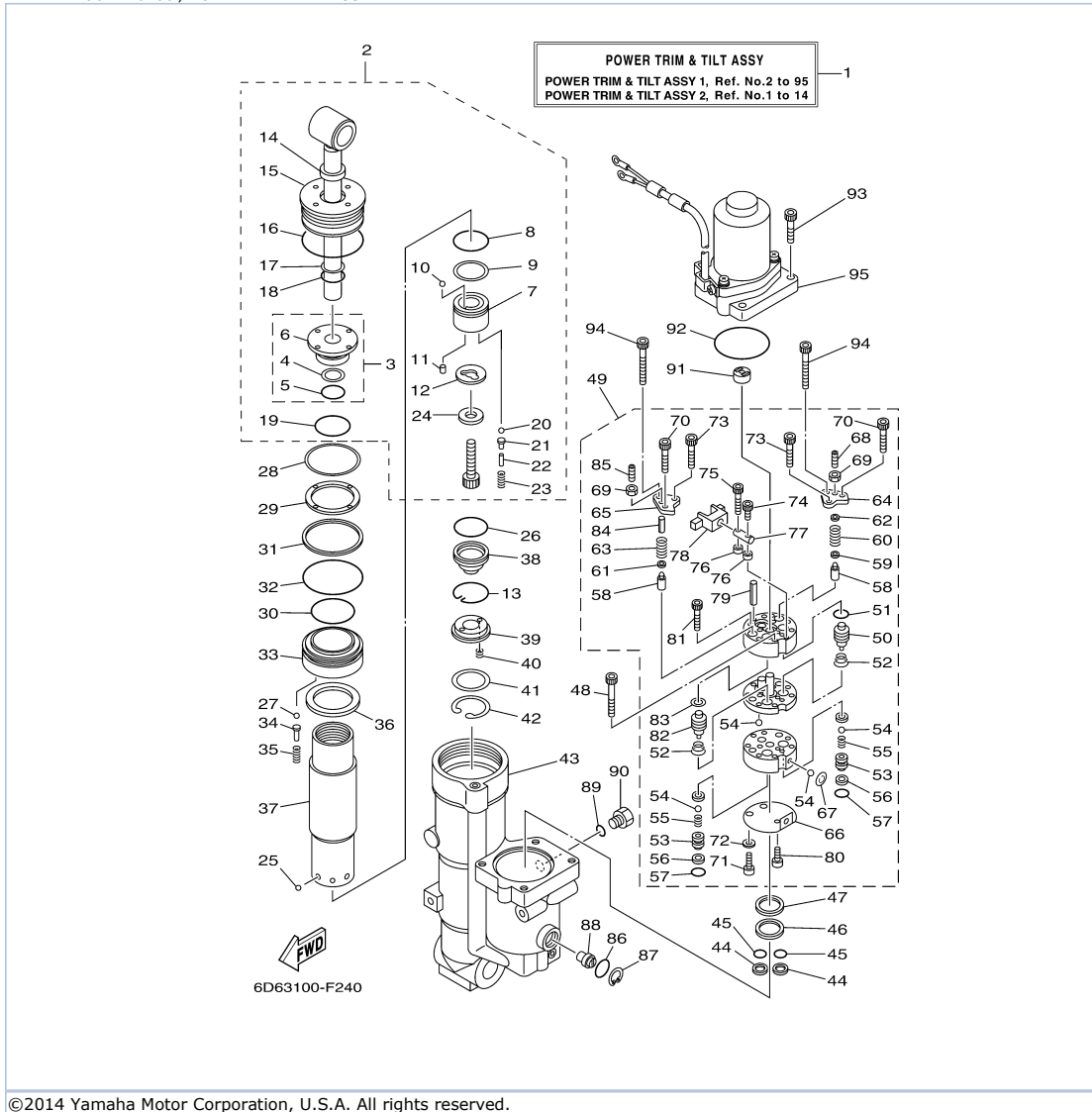

©2014 Yamaha Motor Corporation, U.S.A. All rights reserved.

## Part List

F90TLR 0406 / POWER TRIM TILT ASSY 1

REF - NO	PART NUMBER	PART NAME	QUANTITY	REMARKS
1	6D8-43800-01-8D	POWER TRIM & TILT ASSY	1	
2	67F-43810-01-00	TILT PISTON SUB ASSY	1	
3	67F-4380R-00-00	.CYLINDER END SUB ASSY	1	
4	6H1-43872-10-00	..RING, BACK UP	1	
5	93210-18397-00	..O-RING	1	
6	67F-43811-00-00	..SCREW, CYLINDER END	1	
7	67F-4385A-01-00	.PISTON, TILT	1	
8	93210-29375-00	.O-RING	1	
9	62X-43871-00-00	.RING, BACK UP	1	
10	93501-08001-00	.BALL	1	
11	93602-07244-00	.PIN, DOWEL	2	
12	67F-22435-00-00	.PLATE, VALVE 2	1	
13	67F-43875-00-00	RING, SNAP	1	
14	6H1-43812-00-00	.SEAL, DUST	1	
15	67F-43821-00-00	.SCREW, TRIM CYLINDER END	1	
16	67F-43861-00-00	.O-RING	1	
17	6H1-43872-10-00	.RING, BACK UP	1	
18	93210-18397-00	.O-RING	1	
19	62X-43862-00-00	.O-RING	1	
20	93501-08001-00	.BALL	2	
21	65W-4386A-00-00	.PIN, ABSORBER VALVE	2	
22	688-4386F-00-00	.PIN, STRAIGHT	2	
23	65W-43853-00-00	.SPRING, MAIN VALVE	2	
24	67F-43893-00-00	.WASHER	1	
25	93503-16003-00	BALL	6	
26	67F-43863-00-00	O-RING	1	
27	93501-08001-00	.BALL	5	
28	67F-43899-00-00	PLATE STOPPER	1	
29	67F-43816-00-00	FILTER 1	1	
30	67F-43862-00-00	O-RING	1	
31	67F-43871-00-00	RING, BACK UP	1	
32	62X-43865-00-00	O-RING	1	
33	67F-4388A-00-00	PISTON, TRIM	1	
34	6T4-4386A-00-00	PIN, ABSORBER VALVE	5	
35	67F-43857-00-00	SPRING, ABSORBER VALVE	5	
36	67F-4381J-00-00	PLATE	1	
37	67F-22471-01-00	CYLINDER, SHOCK ABSORBER	1	
38	67F-4381B-00-00	FREE PISTON SUB ASSY	1	
39	62X-43899-00-00	PLATE STOPPER	1	
40	62X-4384H-00-00	SPRING	2	
41	1UF-22434-00-00	PLATE, VALVE 1	1	
42	62X-43875-00-00	RING, SNAP	1	
43	6D8-4380K-00-00	CYLINDER, TILT SUB ASSY	1	
44	6C6-43817-00-00	FILTER 2	2	
45	69J-4389J-00-00	.O-RING	2	
46	6C5-43816-00-00	FILTER 1	1	
47	6C5-4380G-00-00	PLATE	1	
48	91312-05045-00	BOLT	2	
49	6D8-43830-00-00	GEAR PUMP ASSY	1	
50	6C6-43841-00-00	.PISTON, SHUTTLE	1	
51	6H1-43883-00-00	.O-RING	1	
52	6C6-43894-00-00	.SPRING, SHUTTLE RETURN	2	
53	6C6-4382E-00-00	.ADAPTOR 2	2	
54	93505-32038-00	.BALL	6	
55	6C6-43853-00-00	.SPRING, MAIN VALVE	2	
56	6C6-4387G-00-00	.WASHER	2	
57	69J-4389J-00-00	.O-RING	2	
58	6C5-43851-00-00	.SEAT, RELIEF VALVE	2	
59	6C5-43893-00-00	.WASHER	1	
60	6D8-43855-00-00	.SPRING, UP RELIEF	1	

61	6C6-43893-00-00	.WASHER	1	
62	6C5-4381K-00-00	.HOLDER	1	
63	6D8-43856-00-00	.SPRING, DOWN RELIEF	1	
64	6C5-4382K-00-00	.CAP, RELIEF VALVE	1	
65	6C5-4382L-00-00	.CAP, RELIEF VALVE	1	
66	6C5-43895-00-00	.SEAT, RELIEF VALVE	1	
67	6C5-43854-00-00	.SPRING, MANUAL RELEASE	1	
68	92A08-03110-00	.SCREW SET	1	
69	95302-03600-00	.NUT	2	
70	91312-05030-00	.BOLT	2	
71	6C6-43878-00-00	.BOLT, SOCKET	2	
72	62Y-4387G-00-00	.WASHER	2	
73	91312-04030-00	.BOLT	2	
74	91312-03016-00	.BOLT	1	
75	6C6-4388E-00-00	.PLUG, TAPER SCREW	1	
76	6C6-4388F-00-00	.SPACER	2	
77	6C6-4386G-00-00	.PIN, STRAIGHT 2	1	
78	6C6-4386E-00-00	.LEVER 1	1	
79	91609-50028-00	.PIN, SPRING	2	
80	91312-03005-00	.BOLT	1	
81	91312-05025-00	.BOLT	2	
82	6C5-43841-00-00	.PISTON, SHUTTLE	1	
83	6C5-43872-00-00	.RING, BACK UP	1	
84	6D8-4381G-00-00	.PIN 1	1	
85	92A08-03012-00	.SCREW SET	1	
86	93210-18397-00	O-RING	1	
87	6H1-43875-00-00	.RING, SNAP	1	
88	6D8-43845-00-00	SCREW, MANUAL RELEASE	1	
89	93210-09165-00	O-RING	1	
90	6H1-43829-00-00	.PLUG, RESERVOIR	1	
91	6D8-43831-00-00	CONNECTOR, SHAFT	1	
92	93210-64488-00	.O-RING	1	
93	65W-43888-00-00	BOLT, SOCKET	4	
94	91312-05050-00	BOLT	2	
95	6D8-43880-01-00	MOTOR ASSY	1	REFER TO POWER TRIM & TILT ASSY 2

F90TLR 0406 / POWER TRIM TILT ASSY 2

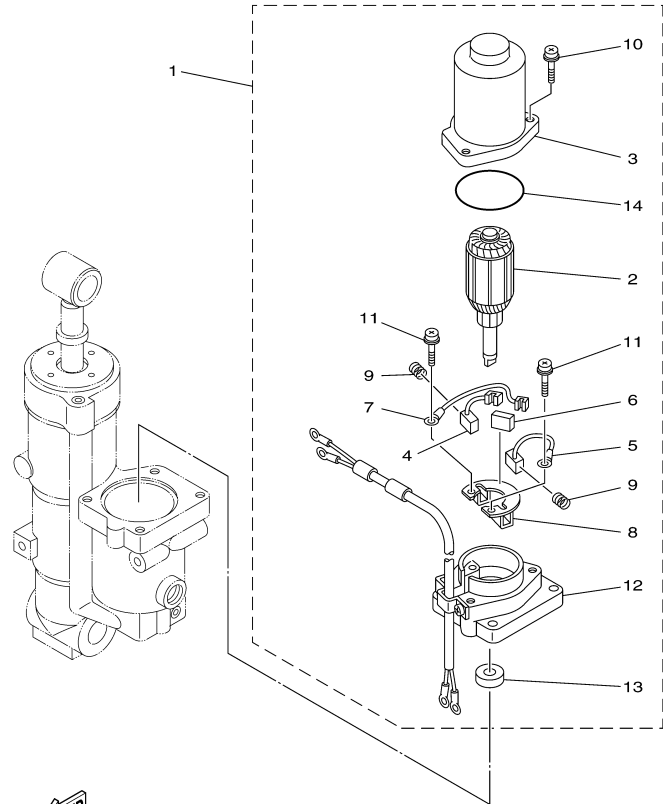

  
6D63100-F250

©2014 Yamaha Motor Corporation, U.S.A. All rights reserved.

## Part List

F90TLR 0406 / POWER TRIM TILT ASSY 2

REF - NO	PART NUMBER	PART NAME	QUANTITY	REMARKS
1	6D8-43880-01-00	MOTOR ASSY	1	
2	6D8-43805-01-00	.ARMATURE ASSY	1	
3	6D8-43804-01-00	.STATOR ASSY	1	
4	6H1-43891-11-00	.BRUSH 1	1	
5	6H1-43892-11-00	.BRUSH 2	1	
6	6H1-82181-10-00	.CIRCUIT BREAKER COMP	1	
7	62X-43807-00-00	.WIRE SUB ASSY	1	
8	6H1-4380F-11-00	.PLATE, BRUSH HOLDER	1	
9	62X-4386K-00-00	.SPRING, BRUSH	2	
10	97980-05225-00	.SCREW, WITH WASHER	3	
11	97602-04216-00	.SCREW, PAN HEAD WITH WASHER	2	
12	6D8-43881-01-00	.FRAME, END	1	
13	93102-08414-00	.OIL SEAL	1	
14	93210-554A9-00	.O-RING	1	

F90TLR 0406 / UPPER CASING

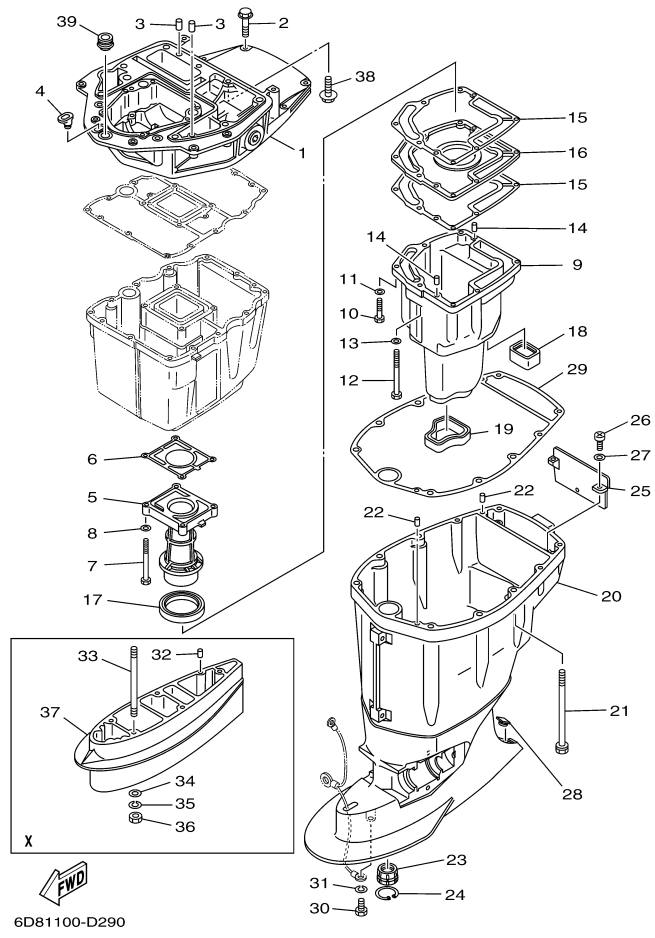

©2014 Yamaha Motor Corporation, U.S.A. All rights reserved.



## Part List

F90TLR 0406 / UPPER CASING

REF - NO	PART NUMBER	PART NAME	QUANTITY	REMARKS
1	6D8-41137-00-94	GUIDE, EXHAUST	1	
2	97575-08540-00	BOLT, WITH WASHER	4	
3	93608-16M16-00	PIN, DOWEL	2	
4	6G1-42727-00-00	GROMMET	1	
5	67F-41131-01-5B	MANIFOLD, EXT. 1	1	
6	67F-41133-A1-00	.GASKET, EXHAUST MANIFOLD 1	1	
7	97075-06070-00	BOLT	4	
8	92995-06600-00	WASHER	4	
9	67F-14711-00-5B	MUFFLER 1	1	
10	97075-06030-00	BOLT	6	
11	92995-06600-00	WASHER	6	
12	97075-06050-00	BOLT	1	
13	92995-06600-00	WASHER	1	
14	93606-19M23-00	PIN, DOWEL	2	
15	67F-41134-A0-00	.GASKET, EXHAUST MANIFOLD	2	
16	67F-45181-00-5B	PLATE	1	
17	67F-41138-00-00	.SEAL, EXT. 1	1	
18	67F-45127-00-00	.SEAL	1	
19	67F-45123-00-00	.GASKET, MUFFLER	1	
20	67F-45111-11-4D	CASING, UPPER	1	
21	90119-10M08-00	BOLT, WITH WASHER	6	
22	93608-16M16-00	PIN, DOWEL	2	
23	67F-45318-00-00	BUSHING, DRIVE SHAFT	1	
24	93420-36M01-00	CIRCLIP	1	
25	67F-45151-00-00	COVER, UPPER CASING	1	
26	97880-06016-00	SCREW, PAN HEAD	2	
27	92990-06600-00	WASHER, PLATE	2	
28	67F-45155-00-00	CAP	1	
29	67F-45113-00-00	.GASKET, UPPER CASING	1	
30	97095-08016-00	BOLT	1	
31	92995-08100-00	WASHER	1	
32	93606-12019-00	.PIN, DOWEL	2	X (26.1)
33	90116-10M05-00	BOLT, STUD	4	X (26.1)
34	92990-10600-00	WASHER, PLATE	4	X (26.1)
35	92990-10100-00	WASHER, SPRING	4	X (26.1)
36	95380-10600-00	NUT	4	X (26.1)
37	688-45211-01-4D	EXTENSION	1	X (26.1)
38	90119-08M58-00	BOLT, WITH WASHER	2	
39	67F-42724-00-00	GROMMET	1	

## Part Notes

F90TLR 0406 / UPPER CASING

PART NUMBER	NOTE TEXT
92990-06600-00 	OEM: This part number is among the Top 100 Most Popular Marine Maintenance Parts as of March 2014.
92990-10600-00 	OEM: This part number is among the Top 100 Most Popular Marine Maintenance Parts as of March 2014.

©2014 Yamaha Motor Corporation, U.S.A. All rights reserved.

F90TLR 0406 / OIL PAN

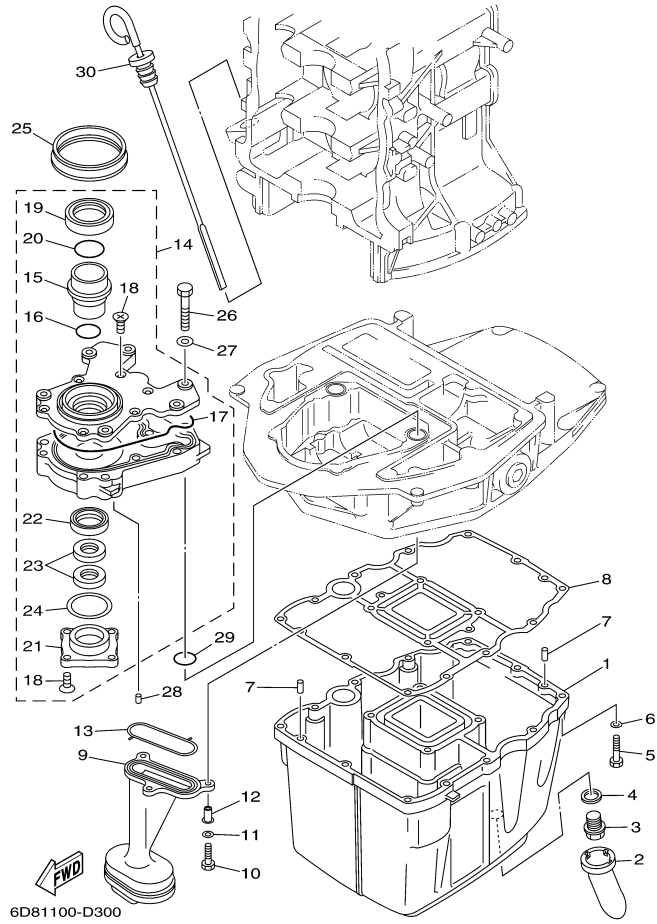

©2014 Yamaha Motor Corporation, U.S.A. All rights reserved.



Part List

F90TLR 0406 / OIL PAN

REF - NO	PART NUMBER	PART NAME	QUANTITY	REMARKS
1	67F-15311-03-5B	OIL PAN	1	
2	63P-15316-00-00	DAMPER 1	1	
3	90340-14M06-00	PLUG, STRAIGHT SCREW	1	
4	90430-14M09-00	.GASKET	1	
5	97075-06025-00	BOLT	12	
6	92995-06600-00	WASHER	12	
7	93606-12019-00	.PIN, DOWEL	2	
8	68V-15312-00-00	.GASKET, OIL PAN	1	
9	67F-13411-00-00	STRAINER, OIL	1	
10	97027-06025-00	BOLT, HEXAGON	3	
11	92907-06600-00	.WASHER, PLATE	3	
12	90387-06M64-00	COLLAR	3	
13	67F-13415-00-00	.SEAL, OIL STRAINER	1	
14	67F-13300-10-00	OIL PUMP ASSY	1	
15	67F-13314-02-00	.SHAFT, PUMP	1	
16	67F-13473-01-00	.O-RING	1	
17	67F-13329-00-00	.GASKET, PUMP COVER	1	
18	67F-13495-00-00	.SCREW	10	
19	67F-13119-01-00	.OIL SEAL	1	
20	67F-13769-00-00	.O-RING	1	
21	67F-13914-00-00	.HOUSING, PUMP	1	
22	67F-13631-03-00	.OIL SEAL	1	
23	67F-13149-00-00	.OIL SEAL	2	
24	67F-13339-00-00	.GASKET, PUMP COVER	1	
25	67F-13338-00-00	SEAL	1	
26	97095-06045-00	.BOLT	6	
27	92995-06600-00	WASHER	6	
28	93604-12M07-00	PIN, DOWEL	2	
29	93210-19MJ1-00	.O-RING	2	
30	6D8-15362-00-00	PLUG, OIL LEVEL	1	

Part Notes

F90TLR 0406 / OIL PAN

PART NUMBER	NOTE TEXT
90430-14M09-00 	OEM: This part number is among the Top 100 Most Popular Marine Maintenance Parts as of March 2014.

©2014 Yamaha Motor Corporation, U.S.A. All rights reserved.

F90TLR 0406 / LOWER CASING DRIVE 1

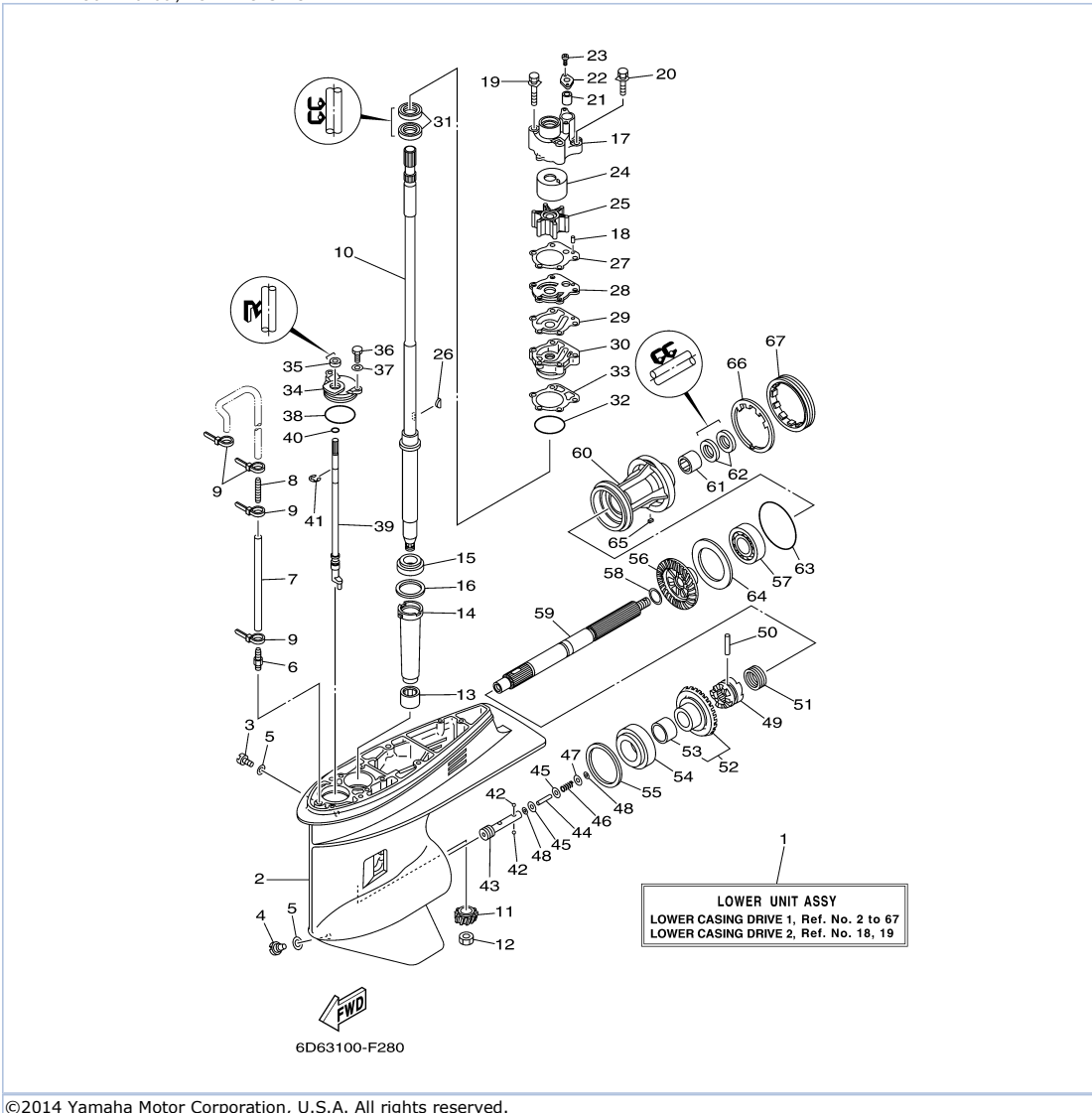

©2014 Yamaha Motor Corporation, U.S.A. All rights reserved.

## Part List







F90TLR 0406 / LOWER CASING DRIVE 1

REF - NO	PART NUMBER	PART NAME	QUANTITY	REMARKS
1	6D9-45300-31-4D	LOWER UNIT ASSY	1	UR X (26.1")
1	6D9-45300-11-4D	LOWER UNIT ASSY	1	UR L (21.1")
2	67F-45301-00-4D	CASING, LOWER	1	
3	90340-08002-00	PLUG, STRAIGHT SCREW	1	
4	688-45341-10-00	PLUG, DRAIN	1	
5	90430-08020-00	.GASKET	2	
6	6E5-45378-00-00	NIPPLE, HOSE	1	
7	90445-07M38-00	HOSE (L300)	1	UR X (26.1")
7	90445-07M31-00	HOSE (L200)	1	UR L (21.1")
8	6E5-83558-10-00	END, NIPPLE	1	
9	90465-11M10-00	CLAMP	4	
10	67F-45501-30-00	DRIVE SHAFT COMP.	1	UR X (26.1")
10	67F-45501-10-00	DRIVE SHAFT COMP.	1	UR L (21.1")
11	6D9-45551-00-00	PINION (13T)	1	
12	90170-16M01-00	NUT	1	
13	93315-52563-00	BEARING	1	
14	688-45536-01-00	SLEEVE, DRIVE SHAFT	1	
15	93332-000U3-00	BEARING	1	
16	688-45587-01-00	SHIM (T:0.10MM)	1	UR
16	688-45587-10-00	SHIM (T:0.12MM)	1	UR
16	688-45587-20-00	SHIM (T:0.15MM)	1	UR
16	688-45587-60-00	SHIM (T:0.50MM)	1	UR
16	688-45587-40-00	SHIM (T:0.30MM)	1	UR
16	688-45587-50-00	SHIM (T:0.40MM)	1	UR
16	688-45587-30-00	SHIM (T:0.18MM)	1	UR
17	67F-44311-01-00	HOUSING, WATER PUMP	1	
18	93604-10M03-00	PIN, DOWEL	2	
19	90119-08M87-00	.BOLT, WITH WASHER	2	
20	90119-08M13-00	.BOLT, WITH WASHER	2	
21	663-44366-00-00	.DAMPER, WATER SEAL 2	1	
22	90480-19M06-00	GROMMET	1	
23	90160-04006-00	SCREW, ROUND TAPPING	2	
24	67F-44322-00-00	.INSERT, CARTRIDGE	1	
25	67F-44352-00-00	.IMPELLER	1	
26	90280-04M04-00	.KEY, WOODRUFF	1	
27	688-44315-A0-00	.GASKET, WATER PUMP	1	
28	67F-44323-00-00	.OUTER PLATE, CARTRIDGE	1	
29	688-44324-A0-00	.GASKET, CARTRIDGE	1	
30	6D8-44341-00-94	HOUSING, WATER PUMP	1	
31	93101-25M03-00	.OIL SEAL	2	
32	93210-46044-00	O-RING	1	
33	688-44316-A0-00	.GASKET, WATER PUMP	1	
34	688-45321-00-00	PLATE	1	
35	93106-09014-00	.OIL SEAL	1	
36	97095-06016-00	BOLT	2	
37	92995-06600-00	WASHER	2	
38	93210-49046-00	.O-RING	1	
39	67F-44150-00-00	SHIFT CAM ASSY	1	
40	93210-07003-00	.O-RING	1	
41	99001-08600-00	CIRCLIP	1	
42	93503-16003-00	BALL	2	
43	67F-45634-00-00	SLIDE, SHIFT	1	
44	6H1-45668-00-00	SHAFT, FREE 1	1	
45	6H1-45635-00-00	PLUNGER, SHIFT	2	
46	90501-12M48-00	SPRING, COMPRESSION	1	
47	90201-03313-00	WASHER, PLATE	1	
48	90183-02M03-00	NUT, SPRING	2	
49	6D8-45631-00-00	CLUTCH, DOG	1	
50	90250-07M02-00	PIN, STRAIGHT	1	
51	688-45633-00-00	RING, CROSS PIN	1	
52	67F-45560-00-00	GEAR 1 (30T)	1	

53	93317-322V0-00	.BEARING	1	
54	93332-000UD-00	BEARING	1	
55	688-45567-01-00	SHIM (T:0.10MM)	1	UR
55	688-45567-10-00	SHIM (T:0.12MM)	1	UR
55	688-45567-20-00	SHIM (T:0.15MM)	1	UR
55	688-45567-60-00	SHIM (T:0.50MM)	1	UR
55	688-45567-40-00	SHIM (T:0.30MM)	1	UR
55	688-45567-50-00	SHIM (T:0.40MM)	1	UR
55	688-45567-30-00	SHIM (T:0.18MM)	1	UR
56	6D9-45571-00-00	GEAR 2 (30T)	1	
57	93306-207U0-00	.BEARING	1	
58	90201-25M05-00	WASHER, PLATE	1	
59	67F-45611-01-00	SHAFT, PROPELLER	1	
60	67F-45331-00-94	HOUSING, BEARING	1	
61	93317-325U0-00	BEARING	1	
62	93101-25M03-00	.OIL SEAL	2	
63	93210-86M39-00	.O-RING	1	
64	67F-45576-00-00	WASHER, THRUST 2	1	
65	90282-04010-00	KEY, STRAIGHT	1	
66	688-45383-02-00	WASHER, CLAW	1	
67	688-45384-00-00	NUT	1	

Part Notes

F90TLR 0406 / LOWER CASING DRIVE 1

PART NUMBER	NOTE TEXT
90430-08020-00 	OEM: This part number is among the Top 100 Most Popular Marine Maintenance Parts as of March 2014.
6D9-45551-00-00 	OEM: This part is discontinued does not supersede. It must be replaced with a gear-set. The forward gear supersedes to this new gear-set is p/n 999990402900 which consists of 1 - 6D9-45551-10-00 PINION GEAR (11T), 1 - 6D9-45560-10-00 FORWARD GEAR (25T), and 1 - 6D9-45571-10-00 REVERSE GEAR (25T). These gears, which were used in production starting in January 2012 on the F75 and F90 models, must be installed as a set when replacing the original gears.
93101-25M03-00 	OEM: This part number is among the Top 100 Most Popular Marine Maintenance Parts as of March 2014.
93106-09014-00 	OEM: This part number is among the Top 100 Most Popular Marine Maintenance Parts as of March 2014.
67F-45560-00-00 	OEM: This part is superseded by a new gear set 999990402900 which consists of 1 - 6D9-45551-10-00 PINION GEAR (11T), 1 - 6D9-45560-10-00 FORWARD GEAR (25T), and 1 - 6D9-45571-10-00 REVERSE GEAR (25T) These gears, which were used in production starting in January 2012 on the F75 and F90 models, must be installed as a set when replacing the original gears.
6D9-45571-00-00 	OEM: This part is discontinued does not supersede. It must be replaced with a gear-set. The forward gear supersedes to this new gear-set is p/n 999990402900 which consists of 1 - 6D9-45551-10-00 PINION GEAR (11T), 1 - 6D9-45560-10-00 FORWARD GEAR (25T), and 1 - 6D9-45571-10-00 REVERSE GEAR (25T). These gears, which were used in production starting in January 2012 on the F75 and F90 models, must be installed as a set when replacing the original gears.
93101-25M03-00 	OEM: This part number is among the Top 100 Most Popular Marine Maintenance Parts as of March 2014.

©2014 Yamaha Motor Corporation, U.S.A. All rights reserved.

F90TLR 0406 / LOWER CASING DRIVE 2

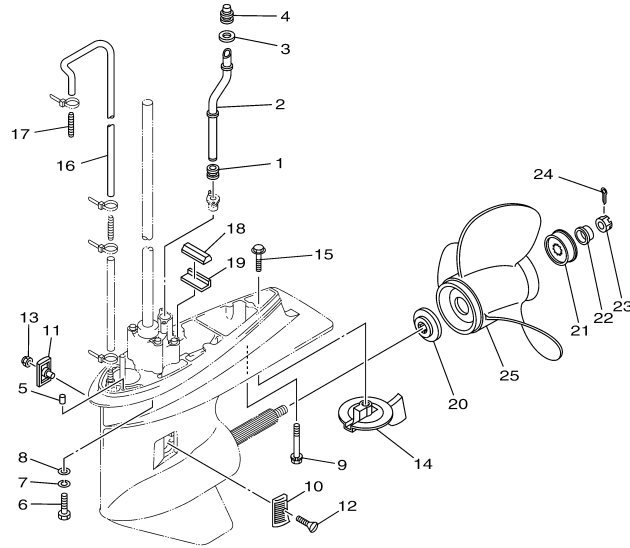

  
6D81100-D320

## Part List

F90TLR 0406 / LOWER CASING DRIVE 2

REF - NO	PART NUMBER	PART NAME	QUANTITY	REMARKS
1	663-44367-00-00	DAMPER, WATER SEAL 3	1	
2	6D8-44361-10-00	TUBE, WATER 1	1	UR X (26.1")
2	6D8-44361-00-00	TUBE, WATER 1	1	UR L (21.1")
3	6D8-44314-00-00	SPACER	1	
4	67F-44365-00-00	DAMPER, WATER SEAL 1	1	
5	93606-12019-00	.PIN, DOWEL	2	
6	97075-10040-00	BOLT	4	L (21.1")
7	92995-10100-00	WASHER	4	L (21.1")
8	92995-10600-00	WASHER	4	L (21.1")
9	90119-08M84-00	BOLT, WITH WASHER	1	UR L (21.1")
9	90119-08M86-00	BOLT, WITH WASHER	1	UR X (26.1")
10	6H1-45214-00-00	COVER, WATER INLET 1	1	
11	6H1-45215-00-00	COVER, WATER INLET 2	1	
12	90151-05M00-00	SCREW, COUNTERSUNK	1	
13	90185-05002-00	NUT, NYLON	1	
14	67F-45371-00-00	TAB-TRIM	1	
15	90105-10M67-00	BOLT, FLANGE	1	
16	90445-07ME0-00	HOSE (L1220)	1	
17	6E5-83558-00-00	END, NIPPLE	1	
18	688-45375-00-00	DAMPER, SEAL	1	
19	663-45376-00-94	GUIDE, SEAL DAMPER	1	
20	688-45987-01-00	SPACER 1	1	
21	67F-45997-00-00	SPACER 2	1	
22	90389-25M00-00	BUSH	1	
23	90171-16011-00	NUT, CASTLE	1	
24	91490-40025-00	PIN. COTTER	1	
25	6E5-45941-00-EL	PROPELLER (3X13"X19"-K)	1	UR
25	688-45930-02-98	PROPELLER (3X13"X17"-K)	1	UR
25	6E5-45945-01-EL	PROPELLER (3X13-1/4"X17"-K)	1	UR
25	6E5-45947-00-EL	PROPELLER (3X13-1/2"X15"-K)	1	UR
25	6E5-45949-00-EL	PROPELLER (3X13-5/8"X13"-K)	1	UR
25	688-45970-03-98	PROPELLER (3 X 13-1/2" X 19" -K) ( )	1	UR
25	688-45972-02-98	PROPELLER (3X13"X21"-K)	1	UR
25	688-45974-02-98	PROPELLER (3X13"X23"-K)	1	UR
25	688-45978-60-98	PROPELLER (3X13-1/2"X16"-K)	1	UR
25	688-45932-60-98	PROPELLER (3X13-1/2"X14"-K)	1	UR
25	6E5-45952-00-EL	PROPELLER (3X13"X23"-K)	1	UR
25	6E5-45954-00-EL	PROPELLER (3X14"X11"-K)	1	UR
25	688-45976-01-98	PROPELLER (3X13"X25"-K)	1	UR
25	6E5-45956-00-EL	PROPELLER (3X13"X25"-K)	1	UR
25	6E5-45943-00-EL	PROPELLER (3X12-5/8"X21"-K)	1	UR

## Part Notes

F90TLR 0406 / LOWER CASING DRIVE 2

PART NUMBER	NOTE TEXT
67F-45371-00-00 	OEM: This part number is among the Top 100 Most Popular Marine Maintenance Parts as of March 2014.

©2014 Yamaha Motor Corporation, U.S.A. All rights reserved.

F90TLR 0406 / STEERING GUIDE

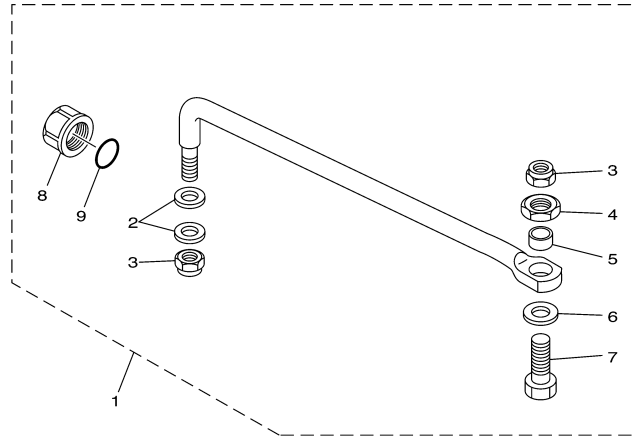

67F0010-9250

## Part List

F90TLR 0406 / STEERING GUIDE

REF - NO	PART NUMBER	PART NAME	QUANTITY	REMARKS
1	67F-61350-00-00	STEERING GUIDE ATTACHMENT KIT	1	AP
2	90201-10M20-00	.WASHER, PLATE	2	
3	90185-09M01-00	.NUT, SELF-LOCKING	2	
4	90170-09M03-00	.NUT	1	
5	90387-10M42-00	.COLLAR	1	
6	90201-10M63-00	.WASHER, PLATE	1	
7	90101-09M01-00	.BOLT	1	
8	6E5-43145-01-00	.CAP, CLAMP BRACKET	1	
9	93210-16275-00	.O-RING	1	



F90TLR 0406 / REPAIR KIT 1

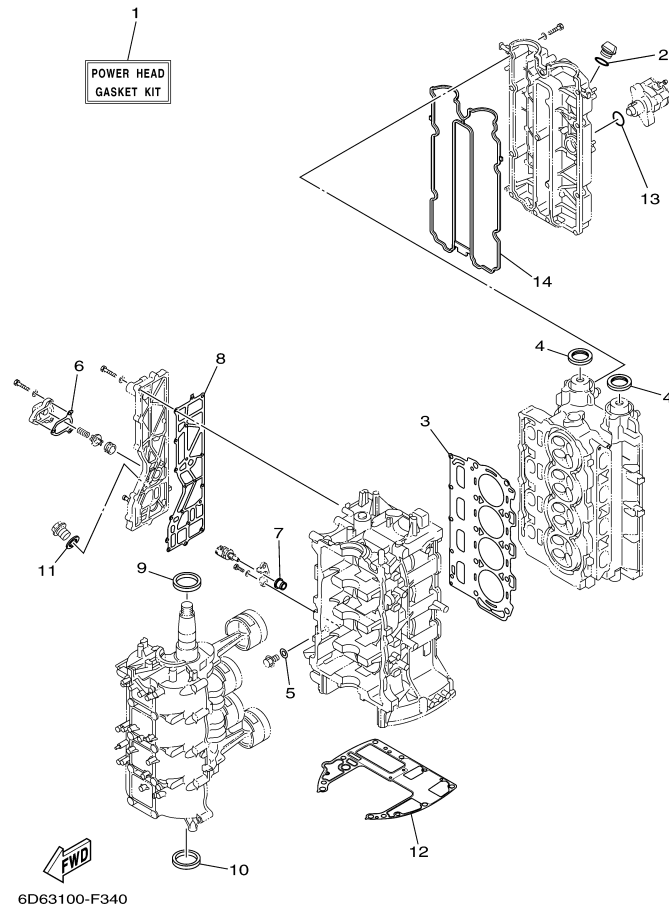

©2014 Yamaha Motor Corporation, U.S.A. All rights reserved.

## Part List

F90TLR 0406 / REPAIR KIT 1

REF - NO	PART NUMBER	PART NAME	QUANTITY	REMARKS
1	6D8-W0001-01-00	POWER HEAD GASKET KIT	1	
2	93210-24M79-00	.O-RING	1	
3	67F-11181-03-00	.GASKET, CYLINDER HEAD 1	1	
4	93102-38M59-00	.OIL SEAL	2	
5	90430-14115-00	.GASKET	1	
6	67F-12435-A0-00	.GASKET	1	
7	68V-85753-00-00	.GASKET, SENDER UNIT	1	
8	67F-41114-A1-00	.GASKET, EXHAUST OUTER COVER	1	
9	93102-48008-00	.OIL SEAL	1	
10	93101-48001-00	.OIL SEAL	1	
11	90430-18130-00	.GASKET	1	
12	68V-11351-00-00	.GASKET, CYLINDER	1	
13	93210-30682-00	.O-RING	1	
14	6D8-11356-01-00	.SEAL, CYLINDER 2	1	

F90TLR 0406 / REPAIR KIT 2

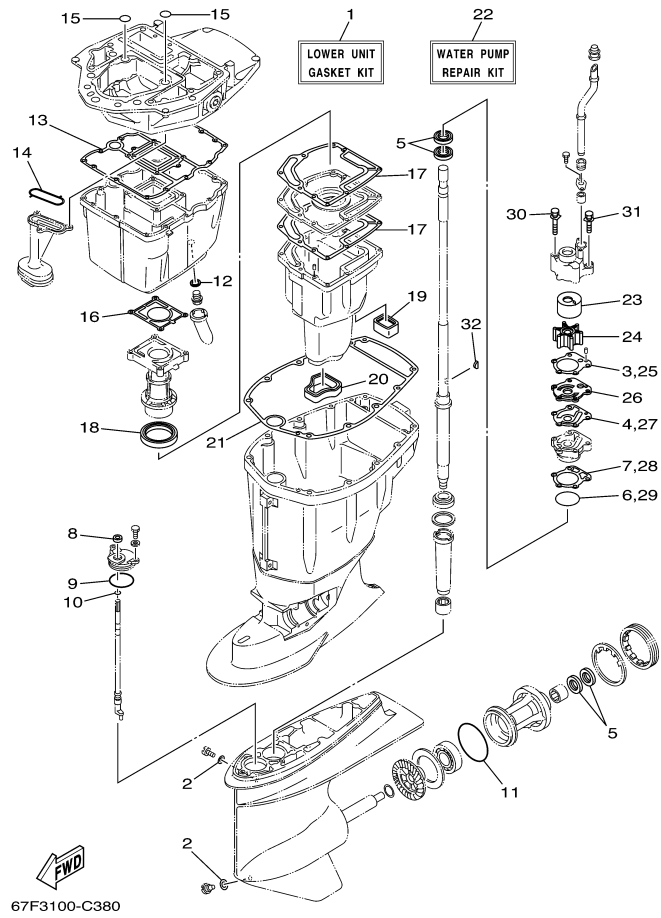

©2014 Yamaha Motor Corporation, U.S.A. All rights reserved.





## Part List

F90TLR 0406 / REPAIR KIT 2

REF - NO	PART NUMBER	PART NAME	QUANTITY	REMARKS
1	67F-W0001-21-00	LOWER UNIT GASKET KIT	1	
2	90430-08020-00	.GASKET	2	
3	688-44315-A0-00	.GASKET, WATER PUMP	1	
4	688-44324-A0-00	.GASKET, CARTRIDGE	1	
5	93101-25M03-00	.OIL SEAL	4	
6	93210-46044-00	.O-RING	1	
7	688-44316-A0-00	.GASKET, WATER PUMP	1	
8	93106-09014-00	.OIL SEAL	1	
9	93210-49046-00	.O-RING	1	
10	93210-07003-00	.O-RING	1	
11	93210-86M39-00	.O-RING	1	
12	90430-14M09-00	.GASKET	1	
13	68V-15312-00-00	.GASKET, OIL PAN	1	
14	67F-13415-00-00	.SEAL, OIL STRAINER	1	
15	93210-19M11-00	.O-RING	2	
16	67F-41133-A1-00	.GASKET, EXHAUST MANIFOLD 1	1	
17	67F-41134-A0-00	.GASKET, EXHAUST MANIFOLD	2	
18	67F-41138-00-00	.SEAL, EXT 1	1	
19	67F-45127-00-00	.SEAL	1	
20	67F-45123-00-00	.GASKET, MUFFLER	1	
21	67F-45113-00-00	.GASKET, UPPER CASING	1	
22	67F-W0078-00-00	WATER PUMP REPAIR KIT	1	
23	67F-44322-00-00	.INSERT, CARTRIDGE	1	
24	67F-44352-00-00	.IMPELLER	1	
25	688-44315-A0-00	.GASKET, WATER PUMP	1	
26	67F-44323-00-00	.OUTER PLATE, CARTRIDGE	1	
27	688-44324-A0-00	.GASKET, CARTRIDGE	1	
28	688-44316-A0-00	.GASKET, WATER PUMP	1	
29	93210-46044-00	.O-RING	1	
30	90119-08M87-00	.BOLT, WITH WASHER	2	
31	90119-08M13-00	.BOLT, WITH WASHER	2	
32	90280-04M04-00	.KEY, WOODRUFF	1	

## Part Notes

F90TLR 0406 / REPAIR KIT 2

PART NUMBER		NOTE TEXT
90430-08020-00		OEM: This part number is among the Top 100 Most Popular Marine Maintenance Parts as of March 2014.
93101-25M03-00		OEM: This part number is among the Top 100 Most Popular Marine Maintenance Parts as of March 2014.
93106-09014-00		OEM: This part number is among the Top 100 Most Popular Marine Maintenance Parts as of March 2014.
90430-14M09-00		OEM: This part number is among the Top 100 Most Popular Marine Maintenance Parts as of March 2014.

©2014 Yamaha Motor Corporation, U.S.A. All rights reserved.

F90TLR 0406 / MODELS IN THIS CATALOG

F75TLR 62P-1008069~1010401  
(6D63)

F90TLR 61P-1021936~1028829

F90TXR 61P-1021936~1028829

F90TJR 61P-1021936~1028829

(6D83)

**ALL THESE MODELS USE THIS SAME PARTS CATALOG.  
BE SURE TO ORDER ONLY THOSE PARTS APPLICABLE  
TO THE DESIRED MODEL.**

©2014 Yamaha Motor Corporation, U.S.A. All rights reserved.

©2014 Yamaha Motor Corporation, U.S.A. All rights reserved.