

F15ELHZ 2001 / TOP COWLING

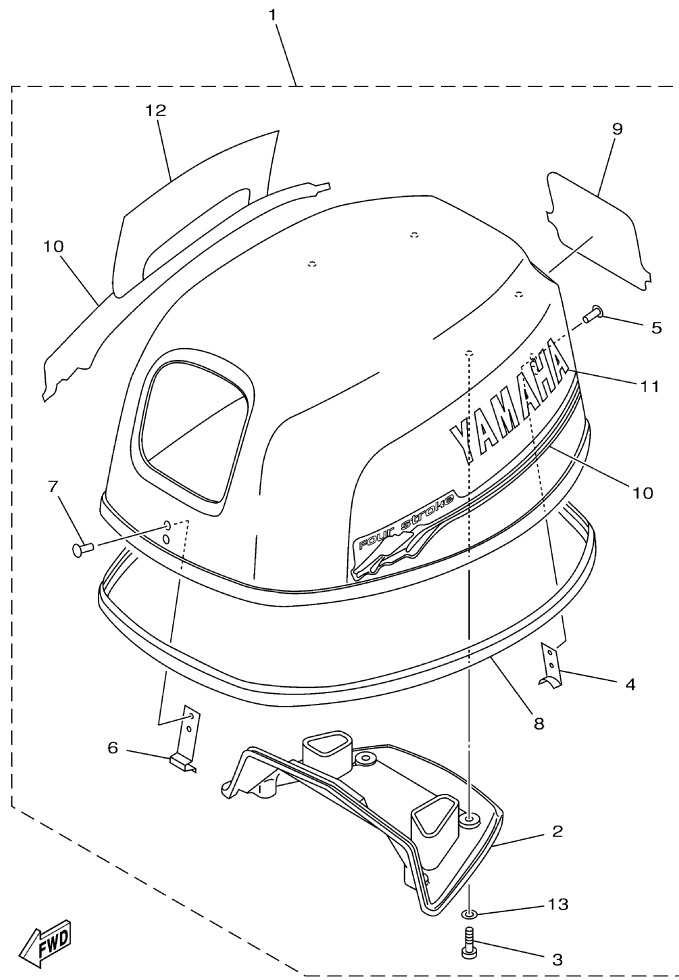

66M0010-8010

Part List

F15ELHZ 2001 / TOP COWLING

REF - NO	PART NUMBER	PART NAME	QUANTITY	REMARKS
1	66M-42610-00-4D	TOP COWLING ASSY	1	
2	66M-42613-00-00	.MOLDING, AIR DUCT	1	
3	97780-60520-00	.SCREW, TAPPING	4	
4	6E0-42651-02-00	.HOOK	1	
5	90266-04M04-00	.RIVET	2	
6	6E7-42652-00-00	.HOOK	1	
7	90266-04M04-00	.RIVET	2	
8	66M-42615-00-00	.SEAL	1	
9	66M-42678-10-00	.GRAPHIC, REAR	1	
10	66M-W0070-10-00	.GRAPHIC SET	1	
11	66M-42681-10-00	.MARK, COWLING	1	
12	66M-42682-10-00	.MARK, COWLING	1	
13	90202-05M38-00	.WASHER, PLATE	4	

F15ELHZ 2001 / CYLINDER CRANKCASE

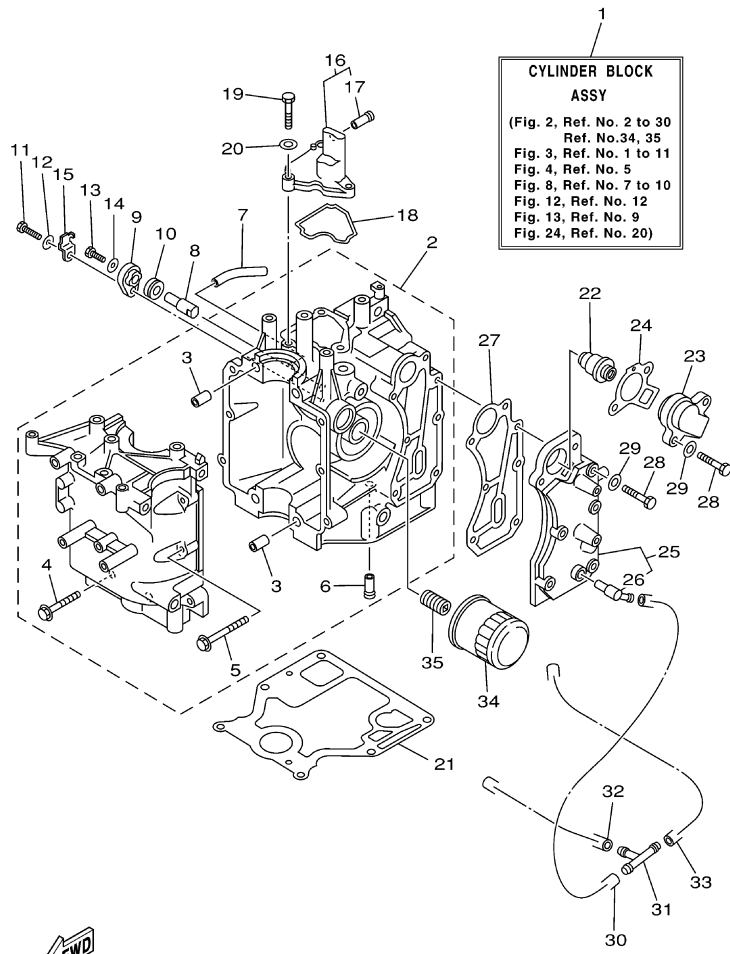

Part List

F15ELHZ 2001 / CYLINDER CRANKCASE

REF - NO	PART NUMBER	PART NAME	QUANTITY	REMARKS
1	66M-W009B-10-1S	CYLINDER BLOCK ASSY	1	FOR FLUSHING KIT
2	66M-15100-01-1S	CRANKCASE ASSY	1	
3	99510-10114-00	.PIN, DOWEL	2	
4	90119-08M66-00	.BOLT, WITH WASHER	4	
5	90119-06M14-00	.BOLT, WITH WASHER	6	
6	6E5-24377-00-00	.PIPE, JOINT 2	1	
7	90445-10M46-00	HOSE (L65)	1	
8	66M-11325-00-00	ANODE	1	
9	66M-11327-00-94	COVER, ANODE	1	
10	66M-11328-00-00	GROMMET, ANODE	1	
11	97095-06020-00	BOLT	1	
12	92995-06600-00	WASHER	1	
13	97095-05012-00	BOLT	1	
14	92995-05600-00	WASHER	1	
15	66M-12535-00-00	PLATE	1	
16	66M-11168-00-1S	COVER, BREATHER	1	
17	6E5-24377-00-00	.PIPE, JOINT 2	1	
18	66M-11357-00-00	.SEAL, CYLINDER 3	1	
19	97095-06020-00	BOLT	3	
20	92995-06600-00	WASHER	3	
21	66M-11351-00-00	.GASKET, CYLINDER	1	
22	66M-12411-00-00	THERMOSTAT	1	
23	6H3-12413-00-1S	COVER, THERMOSTAT	1	
24	62Y-12414-00-00	.GASKET, COVER	1	
25	66M-41113-10-1S	OUTER COVER, EXHAUST	1	FOR FLUSHING KIT
26	676-11372-00-00	.NIPPLE, HOSE	1	
27	66M-41114-00-00	.GASKET, EXHAUST OUTER COVER	1	
28	97013-06030-00	BOLT	7	
29	92903-06600-00	WASHER, PLATE	7	
30	90445-09061-00	HOSE (L65)	1	
31	688-24378-00-00	PIPE, JOINT 3	1	
32	90445-09086-00	HOSE (L170)	1	
33	90445-09105-00	HOSE (L300)	1	
34	5GH-13440-00-00	ELEMENT ASSY, OIL CLEANER	1	
35	90401-20M00-00	BOLT, UNION	1	

Part Notes

F15ELHZ 2001 / CYLINDER CRANKCASE

PART NUMBER	NOTE TEXT
62Y-12414-00-00 	OEM: This part number is among the Top 100 Most Popular Marine Maintenance Parts as of March 2014.

©2014 Yamaha Motor Corporation, U.S.A. All rights reserved.

F15ELHZ 2001 / CRANKSHAFT PISTON

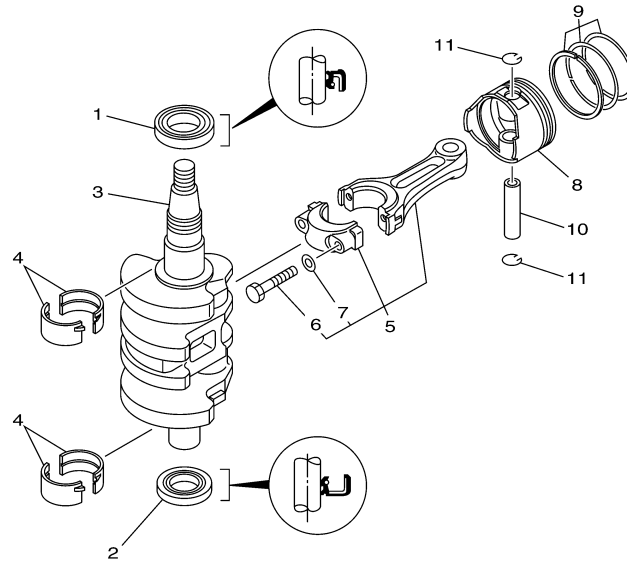

66M0010-8030

Part List

F15ELHZ 2001 / CRANKSHAFT PISTON

REF - NO	PART NUMBER	PART NAME	QUANTITY	REMARKS
1	93102-35M51-00	.OIL SEAL	1	
2	93102-25M52-00	.OIL SEAL	1	
3	66M-11411-00-00	CRANKSHAFT	1	
4	66M-11416-00-00	PLANE BEARING, CRANKSHAFT 1	4	UR BROWN
4	66M-11416-20-00	PLANE BEARING, CRANKSHAFT 1	4	UR BLUE
4	66M-11416-10-00	PLANE BEARING, CRANKSHAFT 1	4	UR BLACK
5	66M-11650-00-00	CONNECTING ROD ASSY	2	
6	66M-11654-00-00	.BOLT, CONNECTING ROD	2	
7	90201-07M01-00	.WASHER, PLATE	2	
8	66M-11631-00-96	PISTON (STD)	2	
8	66M-11636-00-00	PISTON (0.50MM O/S)	2	AP
8	66M-11635-00-00	PISTON (0.25MM O/S)	2	AP
9	66M-11603-00-00	PISTON RING SET (STD)	2	
9	66M-11605-00-00	PISTON RING SET (0.50MM O/S)	2	AP
9	66M-11604-00-00	PISTON RING SET (0.25MM O/S)	2	AP
10	634-11633-00-00	PIN, PISTON	2	
11	93450-15023-00	CIRCLIP	4	

F15ELHZ 2001 / CYLINDER CRANKCASE 2

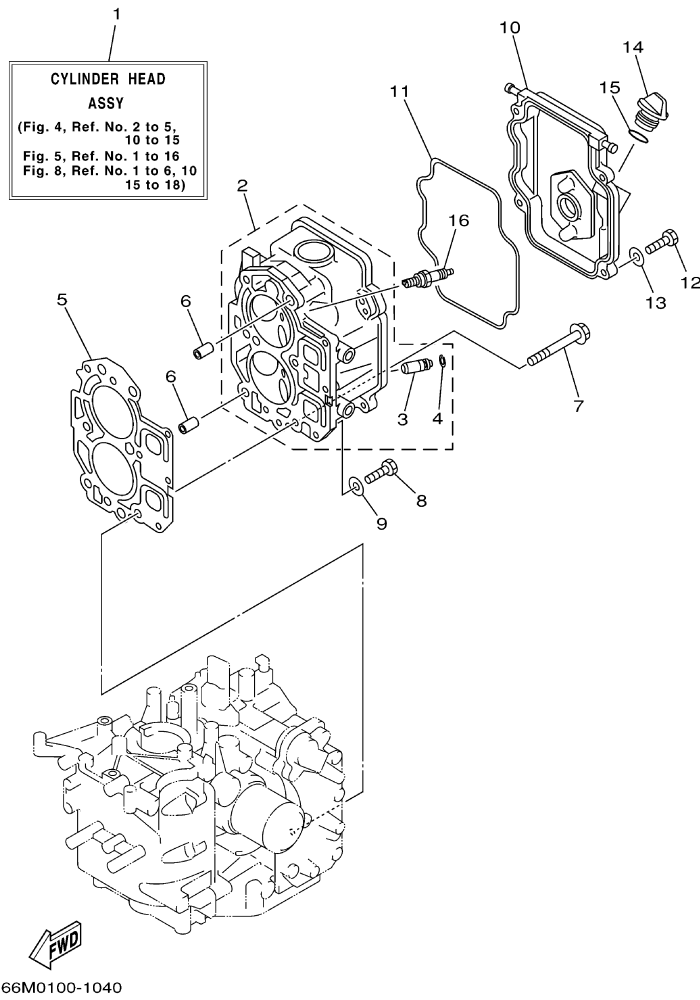

Part List

F15ELHZ 2001 / CYLINDER CRANKCASE 2

REF - NO	PART NUMBER	PART NAME	QUANTITY	REMARKS
1	66M-W009A-01-1S	CYLINDER HEAD COMPLETE	1	
2	66M-11111-01-1S	HEAD, CYLINDER 1	1	
3	66M-11133-10-00	.GUIDE, VALVE 1	4	
4	93450-09M01-00	.CIRCLIP	4	
5	66M-11181-00-00	.GASKET, CYLINDER HEAD 1	1	
6	99510-10114-00	PIN, DOWEL	2	
7	90105-08M78-00	BOLT, FLANGE	6	
8	97013-06025-00	BOLT	3	
9	92903-06600-00	WASHER, PLATE	3	
10	66M-11191-00-1S	COVER, CYLINDER HEAD 1	1	
11	66M-11356-00-00	.SEAL, CYLINDER 2	1	
12	97095-06020-00	BOLT	4	
13	92995-06600-00	WASHER	4	
14	6G8-15363-00-00	PLUG, OIL	1	
15	93210-24M79-00	.O-RING	1	
16	NGK-DPR6E-A9-00	PLUG, SPARK (NGK DPR6EA-9)	2	

F15ELHZ 2001 / VALVE

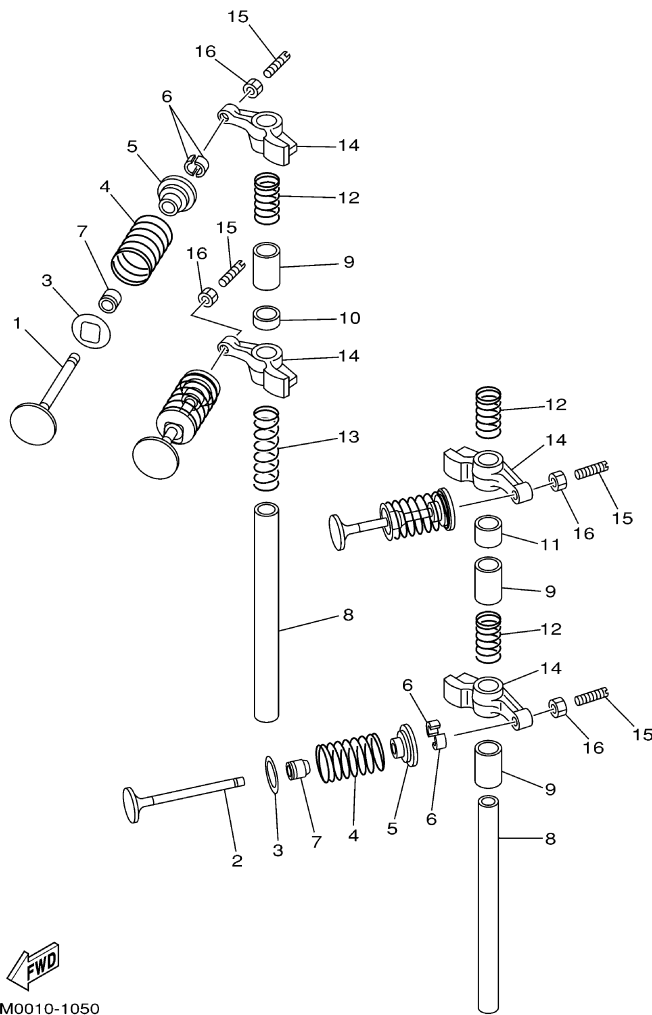

66M0010-1050

Part List

F15ELHZ 2001 / VALVE

REF - NO	PART NUMBER	PART NAME	QUANTITY	REMARKS
1	66M-12111-00-00	VALVE, INTAKE	2	
2	66M-12121-00-00	VALVE, EXHAUST	2	
3	66M-12116-00-00	SEAT, VALVE SPRING	4	
4	66M-12113-00-00	SPRING, VALVE INNER	4	
5	30X-12117-00-00	RETAINER, VALVE SPRING	4	
6	30X-12118-00-00	LOCK, VALVE SPRING RETAINER	8	
7	51Y-12119-00-00	SEAL, VALVE STEM	4	
8	66M-12146-00-00	SHAFT, ROCKER	2	
9	90387-13M56-00	COLLAR	3	
10	90387-13001-00	COLLAR	1	
11	90387-13002-00	COLLAR	1	
12	90501-12M40-00	SPRING, COMPRESSION	3	
13	90501-12M41-00	SPRING, COMPRESSION	1	
14	66M-12151-10-00	ARM, VALVE ROCKER	4	
15	62Y-12159-00-00	SCREW, VALVE ADJUSTING	4	
16	62Y-12158-00-00	NUT, LOCK	4	

F15ELHZ 2001 / INTAKE

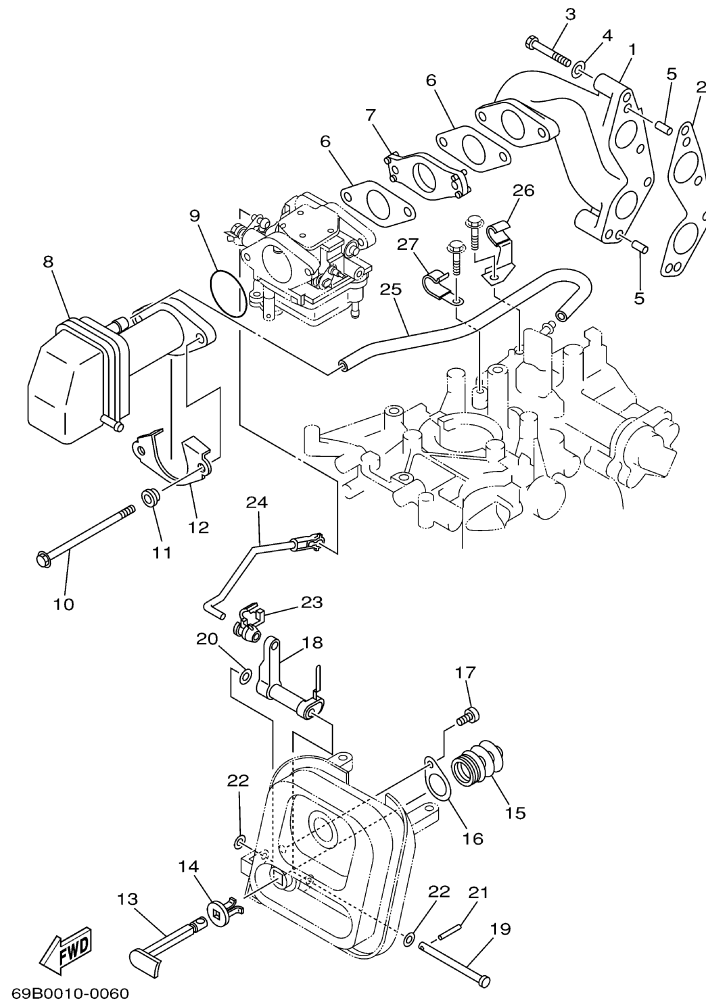

©2014 Yamaha Motor Corporation, U.S.A. All rights reserved.

Part List

F15ELHZ 2001 / INTAKE

REF - NO	PART NUMBER	PART NAME	QUANTITY	REMARKS
1	66M-13641-00-94	MANIFOLD 1	1	
2	66M-13645-00-00	.GASKET, MANIFOLD 1	1	
3	97095-06040-00	.BOLT	4	
4	92995-06600-00	WASHER	4	
5	93606-12019-00	.PIN, DOWEL	2	
6	66M-13646-00-00	.GASKET, MANIFOLD 2	2	
7	66M-14271-00-00	INSULATOR	1	
8	66M-14440-00-00	SILENCER ASSY, INTAKE	1	
9	93210-35M86-00	.O-RING	1	
10	90119-06M76-00	BOLT, WITH WASHER	2	
11	90387-06M79-00	COLLAR	2	
12	66M-14477-00-00	PLATE	1	
13	66M-41271-00-00	KNOB, CHOKE	1	
14	689-41273-00-00	GROMMET	1	
15	66M-41292-00-00	BUSH 2	1	
16	66M-41298-00-00	WASHER 2	1	
17	97780-50510-00	SCREW, TAPPING	1	
18	66M-41252-00-00	LEVER, CHOKE 1	1	
19	90240-05M20-00	PIN, CLEVIS	1	
20	90206-05005-00	WASHER, WAVE	1	
21	91690-20016-00	PIN, SPRING	1	
22	90202-05088-00	WASHER, PLATE	2	
23	6R5-41237-00-00	JOINT, LINK	1	
24	66M-41256-00-00	ROD, CHOKE 1	1	
25	66M-15373-00-00	PIPE, BREATHER	1	
26	90465-08M82-00	CLAMP	1	
27	90465-08M83-00	CLAMP	1	

F15ELHZ 2001 / CARBURETOR

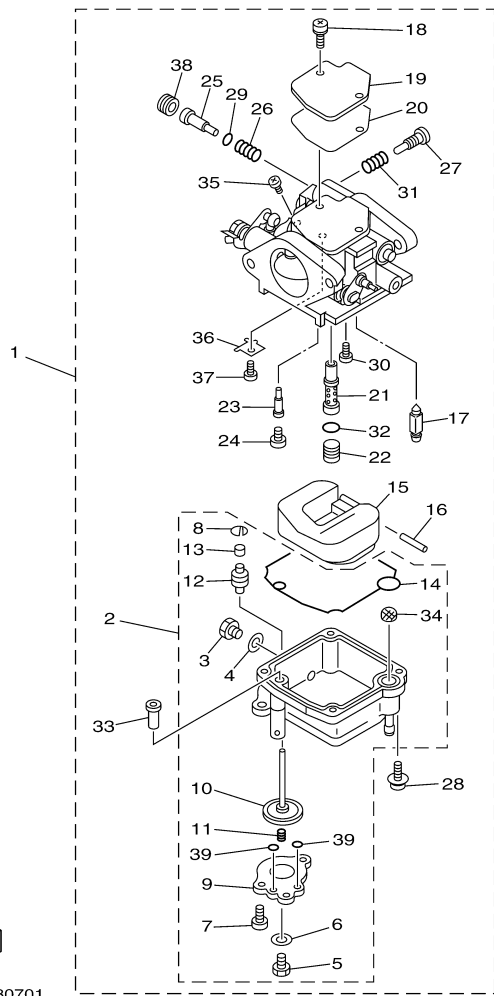



66M010080701
Revised: 7-10-2012

Part List

F15ELHZ 2001 / CARBURETOR

REF - NO	PART NUMBER	PART NAME	QUANTITY	REMARKS
1	66M-14301-11-00	CARBURETOR ASSY 1	1	
2	66M-14381-02-00	.BODY, FLOAT CHAMBER	1	
3	62Y-14383-00-00	..SCREW, DRAIN	1	
4	66M-14398-00-00	..GASKET	1	
5	677-14383-01-00	..SCREW, DRAIN	1	
6	6L2-14398-00-00	..GASKET	1	
7	66M-14325-00-00	..SCREW, PAN HEAD	3	
8	66M-14377-00-00	..STOPPER	1	
9	66M-14958-00-00	..COVER, DIAPHRAGM	1	
10	66M-14368-01-00	..DIAPHRAGM ASSY 1	1	
11	6G8-14275-02-00	..SPRING	1	
12	66M-14239-00-00	..SEAL	1	
13	66M-14225-00-00	..CAP	1	
14	66M-14384-00-00	..GASKET, FLOAT CHAMBER	1	
15	6L2-14385-00-00	.FLOAT	1	
16	6E5-14386-01-00	.PIN, FLOAT	1	
17	6L2-14392-00-00	.VALVE	1	
18	97980-04110-00	.SCREW, WITH WASHER	2	
19	6L2-14157-00-00	.COVER, MIXING	1	
20	62Y-14399-00-00	.GASKET	1	
21	66M-14341-00-00	.NOZZLE, MAIN	1	
22	66M-14343-52-00	.JET, MAIN (#104)	1	
23	66M-14342-23-00	.JET, PILOT (#45)	1	
24	66M-14355-00-00	.PLUG	1	
25	5H0-14323-00-00	.SCREW, AIR ADJUSTING	1	
26	30X-14334-00-00	.SPRING, AIR ADJUSTING	1	
27	62Y-14321-00-00	.SCREW, THROTTLE	1	
28	97980-04112-00	.SCREW, WITH WASHER	4	
29	62Y-14397-00-00	.O-RING	1	
30	98980-04006-00	.SCREW, BIND	1	
31	646-14212-01-00	.SPRING, PILOT ADJUSTING	1	
32	6F5-14397-00-00	.O-RING	1	
33	66M-14272-00-00	.CHECK VALVE ASSY	1	
34	66M-14827-00-00	.FILTER	1	
35	97890-04005-00	.SCREW, PAN HEAD	1	
36	66M-14157-00-00	.PLATE	1	
37	98580-03005-00	.SCREW, PAN HEAD	1	
38	6G8-1432A-01-00	.PLUG	1	
39	69M-24533-00-00	..O-RING	2	

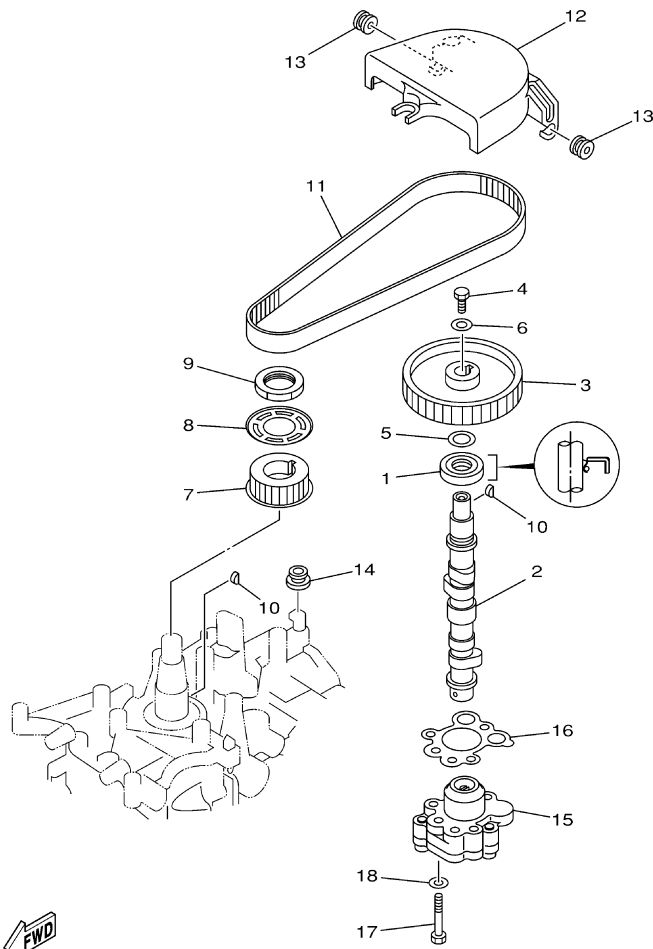
F15ELHZ 2001 / OIL PUMP



66M0010-1080

Part List

F15ELHZ 2001 / OIL PUMP

REF - NO	PART NUMBER	PART NAME	QUANTITY	REMARKS
1	93102-18M21-00	.OIL SEAL	1	
2	66M-12171-10-00	CAMSHAFT 1	1	UR EH (EH)
2	66M-12170-00-00	CAMSHAFT ASSY 1	1	UR MH (MH)
3	66M-11537-00-94	GEAR, DRIVEN	1	
4	97013-06016-00	BOLT	1	
5	90201-13201-00	WASHER, PLATE	1	
6	90201-06M94-00	WASHER, PLATE	1	
7	66M-11536-10-00	GEAR, DRIVE	1	
8	66M-11557-00-00	WASHER 1	1	
9	90170-28M37-00	NUT	1	
10	90280-03M01-00	.KEY, WOODRUFF	2	
11	66M-46241-00-00	V-BELT	1	
12	66M-46297-00-00	COVER, DUST	1	
13	90480-10M16-00	.GROMMET	2	
14	90480-12072-00	GROMMET	1	
15	66M-13300-10-00	OIL PUMP ASSY	1	
16	66M-13329-10-00	.GASKET, PUMP COVER	1	
17	97095-06035-00	BOLT	3	
18	92995-06600-00	WASHER	3	

Part Notes

F15ELHZ 2001 / OIL PUMP

PART NUMBER	NOTE TEXT
90480-12072-00 	OEM: GROMMET used on F115TLR and F/LF115TXR 0410 Production and Earlier

©2014 Yamaha Motor Corporation, U.S.A. All rights reserved.

F15ELHZ 2001 / FUEL

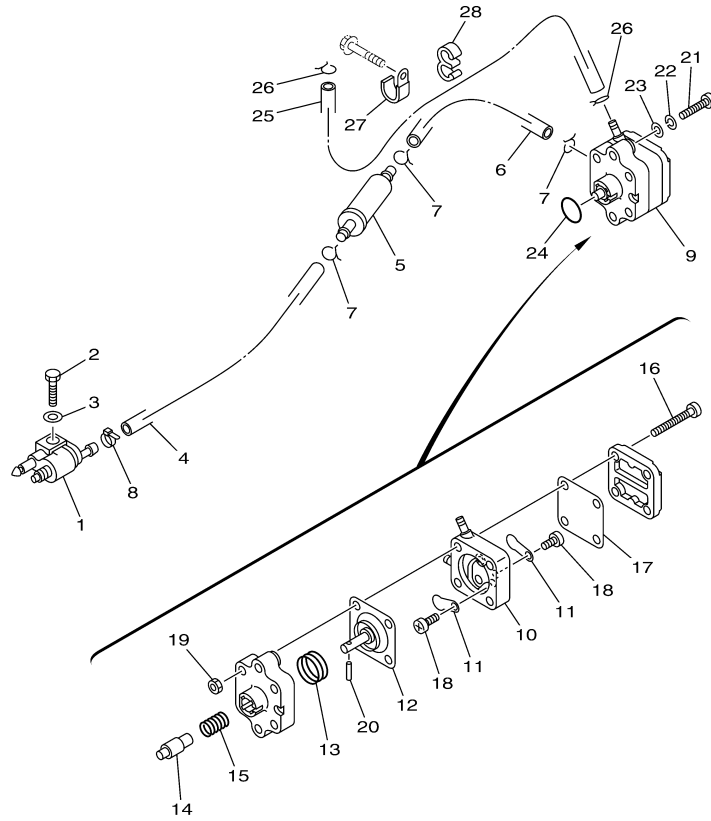

66M0010-9090

Part List

F15ELHZ 2001 / FUEL

REF - NO	PART NUMBER	PART NAME	QUANTITY	REMARKS
1	6G1-24304-02-00	FUEL PIPE JOINT COMP. 1	1	
2	97095-06020-00	BOLT	1	
3	92995-06600-00	WASHER	1	
4	90445-10M40-00	HOSE (L330)	1	
5	65W-24251-00-00	STRAINER 1	1	
6	90445-10M20-00	HOSE (L150)	1	
7	90467-09M03-00	CLIP	3	
8	90465-11M10-00	CLAMP	1	
9	66M-24410-01-00	FUEL PUMP ASSY	1	
10	66M-24413-01-00	.BODY 2	1	
11	6A0-24421-01-00	.VALVE, CHECK	2	
12	66M-24411-00-00	.DIAPHRAGM	1	
13	66M-24423-00-00	.SPRING, DIAPHRAGM	1	
14	66M-13131-00-00	.PLUNGER	1	
15	66M-24454-00-00	.SPRING	1	
16	66M-24444-00-00	.SCREW	4	
17	66M-24471-00-00	.DIAPHRAGM	1	
18	6E7-14325-00-00	.SCREW, PAN HEAD	2	
19	95380-05600-00	.NUT	4	
20	66M-24374-00-00	.PIN	1	
21	97880-06030-00	SCREW, PAN HEAD	2	
22	92990-06100-00	..WASHER, SPRING	2	
23	92990-06600-00	WASHER, PLATE	2	
24	93210-20M65-00	.O-RING	1	
25	90445-10M93-00	HOSE (L370)	1	
26	90467-09M03-00	CLIP	2	
27	90465-06M86-00	.CLAMP	1	
28	90464-09M31-00	CLAMP	1	

Part Notes

F15ELHZ 2001 / FUEL

PART NUMBER	NOTE TEXT
92990-06600-00 	OEM: This part number is among the Top 100 Most Popular Marine Maintenance Parts as of March 2014.

©2014 Yamaha Motor Corporation, U.S.A. All rights reserved.

F15ELHZ 2001 / FUEL 2

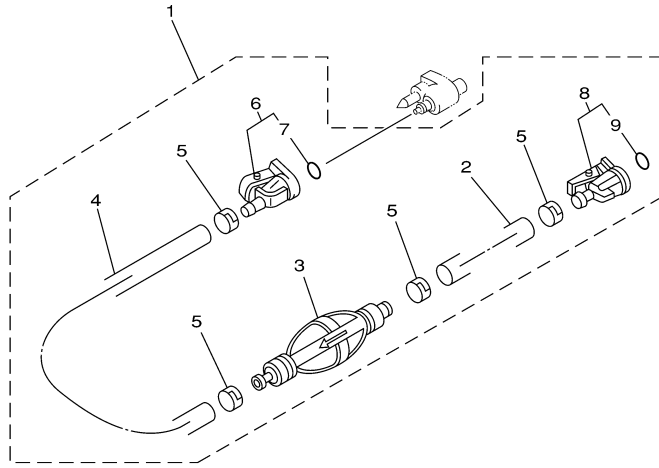

6960100-0050

Part List

F15ELHZ 2001 / FUEL 2

REF - NO	PART NUMBER	PART NAME	QUANTITY	REMARKS
1	6Y1-24306-53-00	FUEL PIPE COMP. 1	1	AP
2	90445-11M06-00	.HOSE (L2050)	1	
3	6Y1-24360-52-00	.PRIMER PUMP ASSY	1	
4	90445-11M05-00	.HOSE (L850)	1	
5	650-24351-51-00	.BAND 1	4	
6	6G1-24305-03-00	.FUEL PIPE JOINT COMP 2	1	
7	93210-08287-00	..O-RING	1	
8	6Y1-24305-04-00	.FUEL PIPE JOINT COMP 2	1	
9	93210-08287-00	..O-RING	1	

F15ELHZ 2001 / STARTER

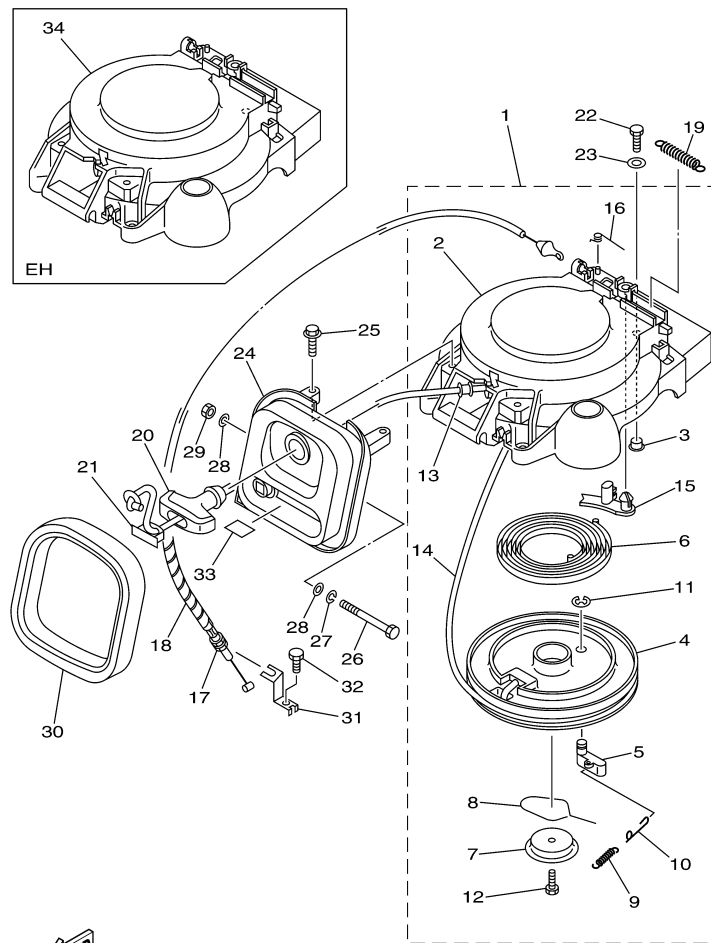

66M0010-8100

Part List

F15ELHZ 2001 / STARTER

REF - NO	PART NUMBER	PART NAME	QUANTITY	REMARKS
1	66M-15710-01-00	STARTER ASSY	1	MH (MH)
2	66M-15711-01-00	.CASE, STARTER	1	(MH)
3	90387-06M05-00	.COLLAR	3	(MH)
4	63V-15714-00-00	.DRUM, SHEAVE	1	(MH)
5	63V-15741-00-00	.PAWL, DRIVE	1	(MH)
6	63V-15713-00-00	.SPRING, STARTER	1	(MH)
7	63V-15716-00-00	.PLATE, DRIVE	1	(MH)
8	63V-15705-01-00	.SPRING, DRIVE PAWL	1	(MH)
9	63V-15767-01-00	.SPRING	1	(MH)
10	63V-15784-01-00	.SPRING, RETURN	1	(MH)
11	63V-15744-00-00	.CIRCLIP	1	(MH)
12	63V-15768-00-00	.BOLT	1	(MH)
13	63V-15764-00-00	.COLLAR 1	1	(MH)
14	90580-50M01-00	.ROPE, STARTER	1	(MH)
15	66T-15794-00-00	.STOPPER	1	(MH)
16	66T-15734-00-00	.SPRING, RETURN	1	(MH)
17	66M-15770-00-00	CABLE COMP., STARTER STOP	1	MH (MH)
18	90446-06M90-00	HOSE (L120)	1	MH (MH)
19	66T-15731-00-00	.SPRING, RETURN	1	MH (MH)
20	6G1-15755-00-00	.HANDLE, STARTER	1	MH (MH)
21	6G1-15779-00-00	.COVER	1	MH (MH)
22	97095-06020-00	BOLT	3	
23	92995-06600-00	WASHER	3	
24	66M-15758-10-00	GUIDE, ROPE	1	UR EH (EH)
24	66M-15758-00-00	GUIDE, ROPE	1	UR MH (MH)
25	90119-06M59-00	BOLT, WITH WASHER	2	
26	97095-06090-00	BOLT	1	
27	92995-06100-00	WASHER, SPRING	1	
28	90201-06M05-00	WASHER, PLATE	2	
29	95380-06700-00	NUT	1	
30	66M-15762-00-00	SEAL, RUBBER 2	1	
31	66M-15774-00-00	STAY 4	1	MH (MH)
32	90109-06M86-00	BOLT	1	MH (MH)
33	66M-84342-00-00	SEAT, EMBLEM	1	
34	66M-15711-10-00	CASE, STARTER	1	EH (EH)

F15ELHZ 2001 / GENERATOR

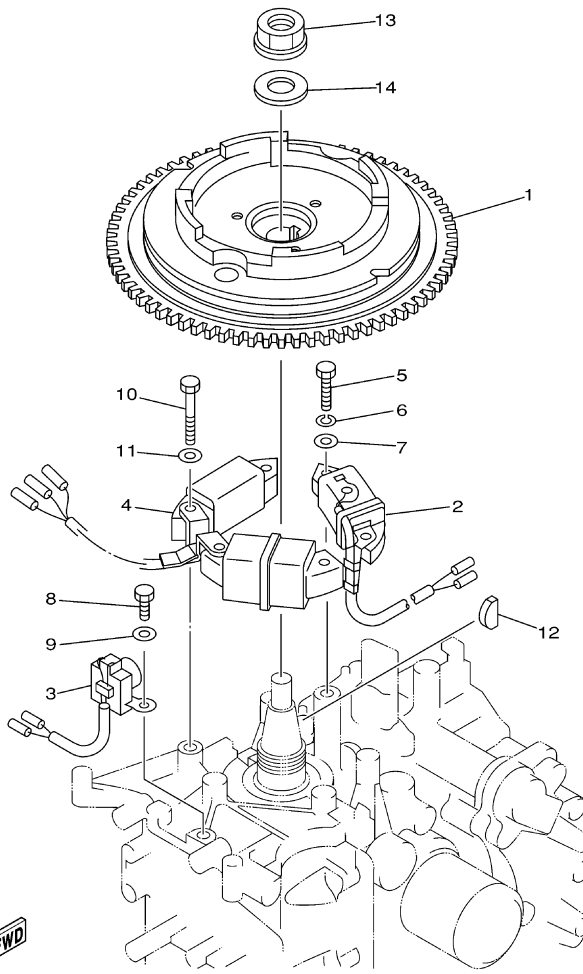

69B0010-0110

Part List

F15ELHZ 2001 / GENERATOR

REF - NO	PART NUMBER	PART NAME	QUANTITY	REMARKS
1	66M-85550-10-00	ROTOR ASSY (WITH RING GEAR)	1	WITH RING GEAR
2	66M-85520-00-00	COIL, CHARGE	1	
3	66M-85580-00-00	COIL, PULSER	1	
4	66M-85533-10-00	COIL, LIGHTING	1	UR EH 10A (EH)
4	66M-85533-00-00	COIL, LIGHTING	1	UR MH 6A (MH)
5	97095-06025-00	BOLT	2	
6	92995-06100-00	WASHER, SPRING	2	
7	92995-06600-00	WASHER	2	
8	97095-06016-00	BOLT	2	
9	92995-06600-00	WASHER	2	
10	97095-06040-00	.BOLT	4	UR EH (EH)
10	97095-06030-00	BOLT	4	UR MH (MH)
11	92995-06600-00	WASHER	4	
12	90280-05013-00	KEY, WOODRUFF	1	
13	90179-16M05-00	NUT	1	
14	90201-16M44-00	WASHER, PLATE	1	

F15ELHZ 2001 / ELECTRICAL 1

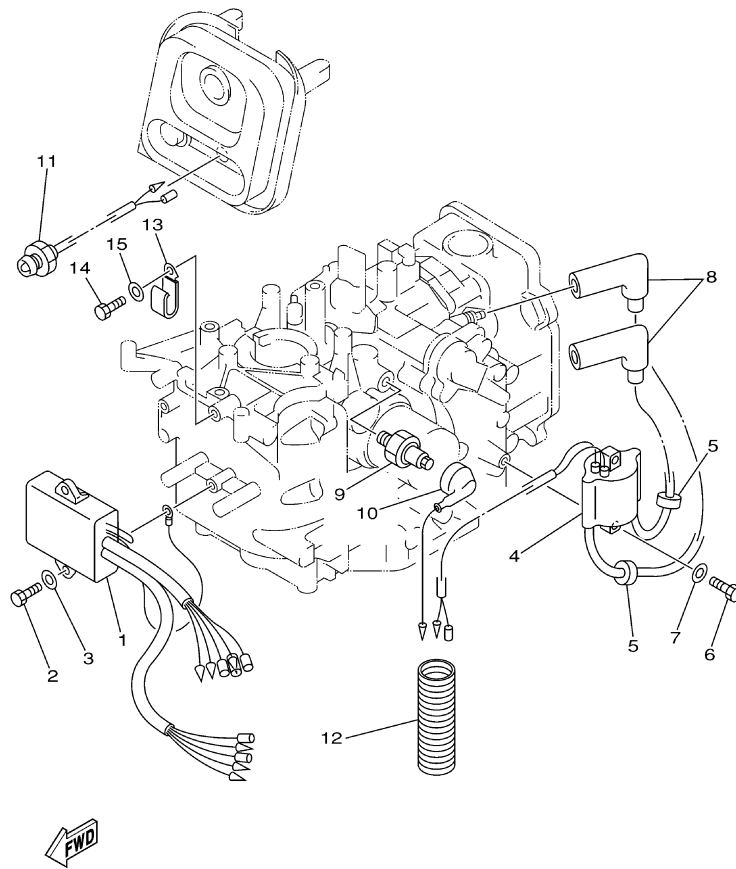

66M0010-1120

Part List

F15ELHZ 2001 / ELECTRICAL 1

REF - NO	PART NUMBER	PART NAME	QUANTITY	REMARKS
1	66M-85540-01-00	C.D.I. UNIT ASSY	1	
2	97095-06020-00	BOLT	2	
3	92995-06600-00	WASHER	2	
4	66M-85570-00-00	IGNITION COIL ASSY	1	
5	90480-25161-00	GROMMET	2	
6	97095-06020-00	BOLT	2	
7	92995-06600-00	WASHER	2	
8	6G8-82370-30-00	PLUG CAP ASSY	2	
9	62Y-82504-10-00	OIL PRESSURE SWITCH ASSY	1	
10	66M-82127-10-00	WIRE, LEAD 2	1	
11	65W-85410-01-00	EMERGENCY SIGNAL LIGHT ASSY	1	
12	6H1-83557-00-00	TUBE	1	
13	90465-06M88-00	CLAMP	1	MH (MH)
14	97095-06016-00	BOLT	1	MH (MH)
15	92995-06600-00	WASHER	1	MH (MH)

F15ELHZ 2001 / ELECTRICAL 2

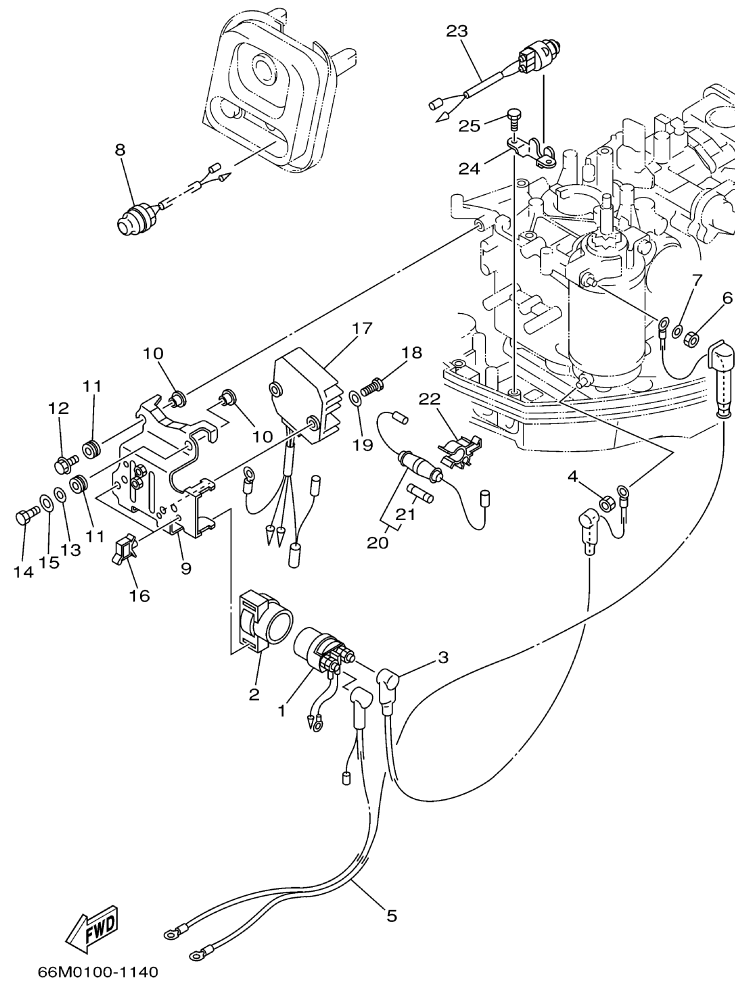

Part List

F15ELHZ 2001 / ELECTRICAL 2

REF - NO	PART NUMBER	PART NAME	QUANTITY	REMARKS
1	6G1-81941-10-00	STARTER RELAY ASSY	1	EH (EH)
2	6G1-81952-00-00	HOLDER, RELAY	1	EH (EH)
3	66M-82117-00-00	WIRE, LEAD	1	EH (EH)
4	65W-8182B-00-00	NUT, SPECIAL	1	EH (EH)
5	66M-82105-00-00	BATTERY CABLE	1	EH (EH)
6	95380-08700-00	NUT	1	EH (EH)
7	92990-08600-00	..WASHER, PLATE	1	EH (EH)
8	65W-81870-00-00	STARTING SWITCH ASSY	1	EH (EH)
9	66M-85542-10-00	BRACKET	1	EH (EH)
10	90387-06M05-00	COLLAR	4	EH (EH)
11	90480-13M24-00	GROMMET	4	EH (EH)
12	95895-06020-00	BOLT, FLANGE	3	EH (EH)
13	90201-06M05-00	WASHER, PLATE	1	EH (EH)
14	97095-06025-00	BOLT	1	EH (EH)
15	92995-06600-00	WASHER	1	EH (EH)
16	90464-09M13-00	CLAMP	2	EH (EH)
17	6G8-81960-A1-00	RECTIFIER ASSY	1	EH (EH)
18	97095-06016-00	BOLT	3	EH (EH)
19	92995-06600-00	WASHER	3	EH (EH)
20	6G8-82150-00-00	FUSE HOLDER ASSY	1	EH (EH)
21	663-82151-00-00	.FUSE (12V-20A)	1	EH (EH)
22	6G5-82152-00-00	HOLDER, FUSE	1	EH (EH)
23	6H3-82540-00-00	NEUTRAL SWITCH ASSY	1	EH (EH)
24	6J8-82554-00-00	STAY, NEUTRAL SWITCH	1	EH (EH)
25	90109-06M86-00	BOLT	2	EH (EH)

F15ELHZ 2001 / STARTING MOTOR

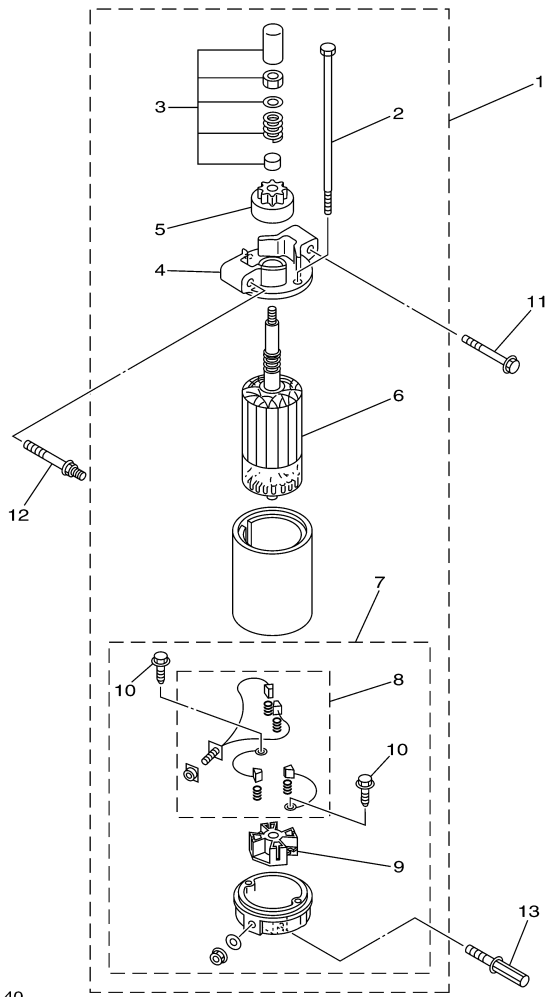



66M0010-0140

Part List

F15ELHZ 2001 / STARTING MOTOR

REF - NO	PART NUMBER	PART NAME	QUANTITY	REMARKS
1	66M-81800-01-00	STARTING MOTOR ASSY	1	EH (EH)
2	65W-81826-00-00	.BOLT	2	(EH)
3	65W-81857-01-00	.RETAINER	1	(EH)
4	66M-81830-00-00	.FRONT BRACKET ASSY	1	(EH)
5	65W-81807-00-00	.GEAR ASSY, STARTING MOTOR	1	(EH)
6	65W-81850-01-00	.ARMATURE ASSY	1	(EH)
7	66M-81820-00-00	.REAR BRACKET ASSY	1	(EH)
8	65W-81801-00-00	..BRUSH SET	1	(EH)
9	65W-81840-00-00	..BRUSH HOLDER ASSY	1	(EH)
10	65W-8182S-00-00	..SCREW	2	(EH)
11	90119-08M39-00	BOLT, WITH WASHER	1	EH (EH)
12	90109-08M78-00	BOLT	1	EH (EH)
13	90109-08M85-00	BOLT	1	EH (EH)

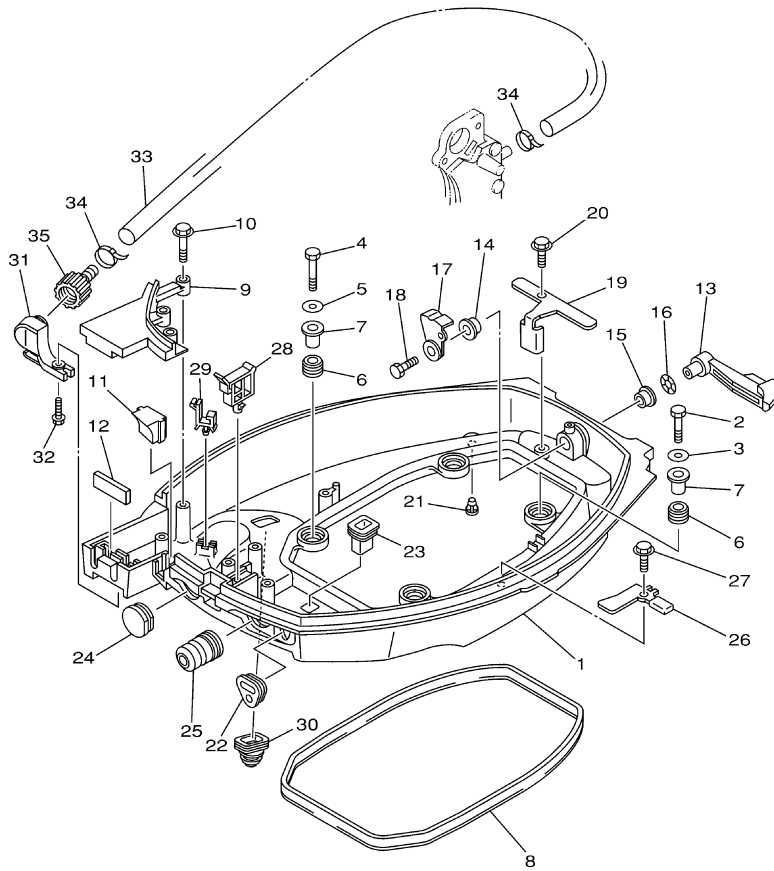
F15ELHZ 2001 / BOTTOM COWLING



66M0110-1160

Part List

F15ELHZ 2001 / BOTTOM COWLING

REF - NO	PART NUMBER	PART NAME	QUANTITY	REMARKS
1	66M-42710-03-4D	BOTTOM COWLING ASSY	1	
2	97095-06035-00	BOLT	2	
3	92995-06600-00	WASHER	2	
4	97095-06025-00	BOLT	2	
5	92995-06600-00	WASHER	2	
6	90480-15M31-00	GROMMET	4	
7	90387-06M52-00	COLLAR	4	
8	66M-42716-00-00	RUBBER, SEAL 1	1	
9	66M-42738-00-4D	PLATE, FITTING	1	
10	90109-06M82-00	BOLT	3	
11	66M-42725-10-00	GROMMET	1	UR EH (EH)
11	66M-42725-00-00	GROMMET	1	UR MH (MH)
12	65W-42727-00-00	GROMMET	1	
13	66M-42815-00-4D	LEVER, CLAMP	1	
14	90386-12M37-00	BUSH	1	
15	90386-12MA2-00	BUSH	1	
16	90206-12052-00	WASHER, WAVE	1	
17	6L2-42816-00-00	LEVER, CLAMP	1	
18	97095-06012-00	BOLT	1	
19	66M-42766-00-00	BRACKET 2	1	
20	90109-06M86-00	BOLT	1	
21	6H3-44391-01-00	NIPPLE, HOSE	1	
22	66M-26326-00-00	GROMMET	1	
23	682-42727-00-00	GROMMET	1	
24	682-42724-00-00	GROMMET	1	
25	65W-42726-00-00	GROMMET	1	
26	66M-42743-00-00	BRACKET	2	
27	90109-06M86-00	BOLT	2	
28	90465-25M57-00	CLAMP	1	
29	90464-09M13-00	CLAMP	1	
30	688-42726-10-00	GROMMET	1	FOR FLUSHING KIT
31	65W-12572-00-00	ADAPTER	1	FLUSHING KIT
32	90109-06M81-00	BOLT	1	FLUSHING KIT
33	66M-12481-00-00	PIPE 1	1	FLUSHING KIT
34	90465-11M10-00	CLAMP	2	FLUSHING KIT
35	6R3-12580-00-00	JOINT ASSY	1	FLUSHING KIT

F15ELHZ 2001 / STEERING

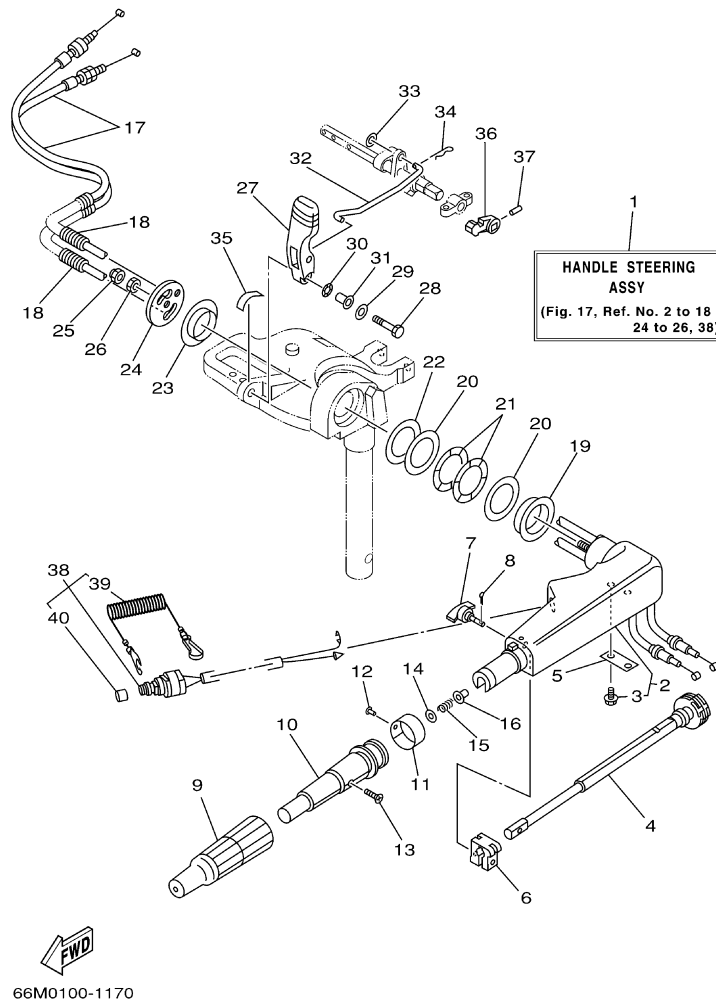



Part List

F15ELHZ 2001 / STEERING

REF - NO	PART NUMBER	PART NAME	QUANTITY	REMARKS
1	66M-W0084-00-4D	HANDLE STEERING ASSY	1	
2	65W-42101-01-4D	HANDLE, STEERING	1	
3	90109-06M86-00	.BOLT	2	
4	65W-42138-00-00	LEVER, THROTTLE	1	
5	65W-42159-00-00	STAY	1	
6	6G1-42126-00-00	FRICITION, STEERING HANDLE GRIP	1	
7	65W-42125-00-00	BOLT, FRICTION ADJUSTING	1	
8	91490-16010-00	PIN. COTTER	1	
9	66M-42177-00-00	RUBBER, HANDLE	1	
10	66M-42119-00-00	GRIP, STEERING HANDLE	1	
11	689-42137-20-00	INDICATOR, THROTTLE	1	
12	90269-02M09-00	RIVET	1	
13	90149-05M13-00	SCREW	1	
14	92903-10600-00	WASHER, PLATE	1	
15	90501-23215-00	SPRING, COMPRESSION	1	
16	90386-08032-00	BUSH	1	
17	66M-26311-00-00	CABLE, THROTTLE 1	2	
18	90446-10M87-00	HOSE (L75)	2	
19	90386-40MA0-00	BUSH	1	
20	90201-43M00-00	WASHER, PLATE	2	
21	90206-43M22-00	WASHER, WAVE	2	
22	90202-43M57-00	WASHER, PLATE	1	
23	90386-40M99-00	BUSH	1	
24	66M-42131-01-00	COVER, HANDLE STEERING	1	
25	95780-10300-00	NUT, FLANGE	1	
26	95380-10700-00	NUT	1	
27	66M-44111-01-00	HANDLE, GEAR SHIFT	1	
28	97095-06030-00	BOLT	1	
29	92995-06600-00	WASHER	1	
30	90206-10M04-00	WASHER, WAVE	1	
31	90387-06M78-00	COLLAR	1	
32	66M-44124-00-00	LINK, SHIFT ROD	1	
33	92990-06200-00	WASHER, PLAIN	1	
34	90468-18008-00	CLIP	1	
35	6E0-44191-11-00	INDICATOR, SHIFT	1	
36	65W-44173-00-00	LEVER, SHIFT CONTROL	1	FOR NEUTRAL SW. (EH)
37	90254-03M05-00	PIN, SPRING	1	FOR NEUTRAL SW. (EH)
38	65W-82575-00-00	ENGINE STOP SWITCH ASSY	1	
39	682-82556-00-00	.LANYARD, STOP SWITCH	1	
40	689-8257Y-00-00	.CAP	1	

Part Notes

F15ELHZ 2001 / STEERING

PART NUMBER		NOTE TEXT
90468-18008-00		OEM: This part number is among the Top 100 Most Popular Marine Maintenance Parts as of March 2014.
682-82556-00-00		OEM: This part number is among the Top 100 Most Popular Marine Maintenance Parts as of March 2014.

©2014 Yamaha Motor Corporation, U.S.A. All rights reserved.

F15ELHZ 2001 / STEERING 2

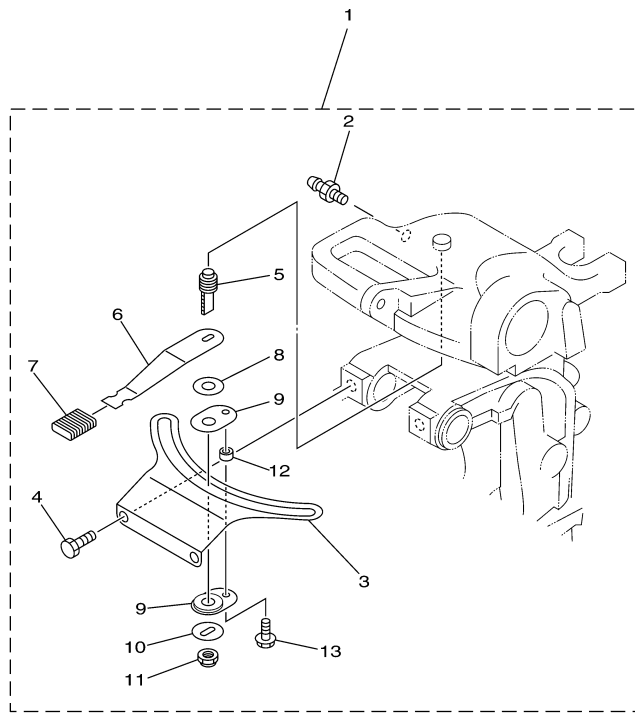

66M0010-8170

Part List

F15ELHZ 2001 / STEERING 2

REF - NO	PART NUMBER	PART NAME	QUANTITY	REMARKS
1	66M-42508-01-00	STEERING FRICTION ASSY	1	
2	93700-06M03-00	.NIPPLE, GREASE	1	
3	66M-42527-00-00	.PLATE, FRICTION	1	
4	90109-08M91-00	.BOLT	2	
5	65W-42562-00-00	.SHAFT, STEERING LOCK	1	
6	66M-42561-00-00	.KNOB, STEERING LOCK	1	
7	689-43633-00-00	.COVER, TILT LEVER	1	
8	90202-10M56-00	.WASHER, PLATE	1	
9	65W-42528-00-00	.PLATE, FRICTION	2	
10	90209-10M26-00	.WASHER	1	
11	90185-10M14-00	.NUT, SELF-LOCKING	1	
12	90387-05M11-00	.COLLAR	1	
13	90119-05M03-00	.BOLT, WITH WASHER	1	

F15ELHZ 2001 / CONTROL

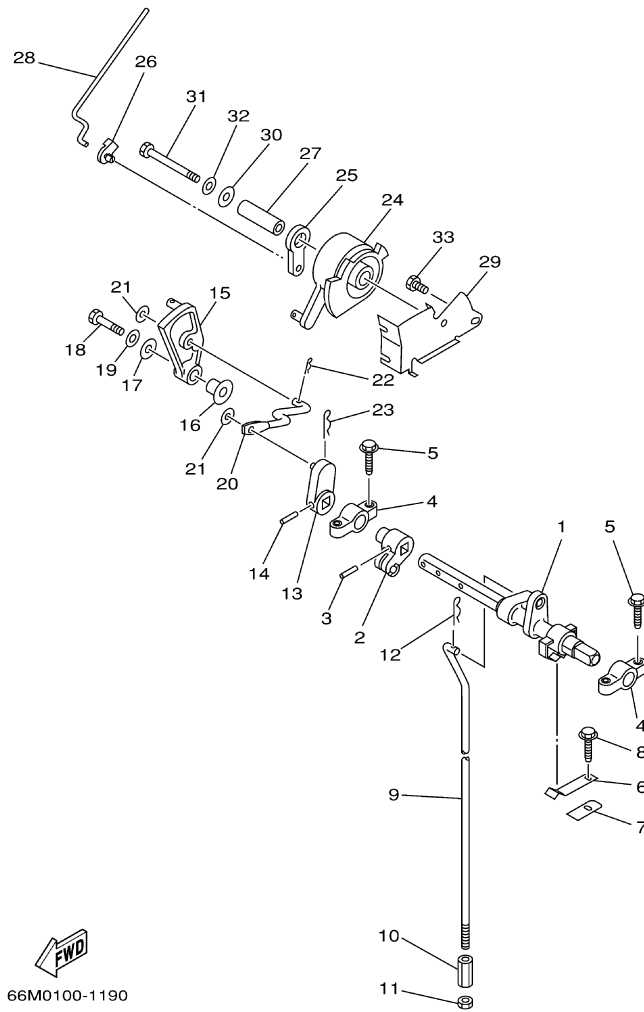

66M0100-1190



Part List

F15ELHZ 2001 / CONTROL

REF - NO	PART NUMBER	PART NAME	QUANTITY	REMARKS
1	65W-44121-00-00	LEVER, SHIFT ROD	1	
2	66M-44122-00-00	BUSHING, SHIFT ROD LEVER	1	
3	90254-03M05-00	PIN, SPRING	1	
4	6F5-41662-00-00	BRACKET 2	2	
5	90109-06M81-00	BOLT	4	
6	65W-44116-00-00	SPRING	1	
7	66R-44114-00-00	STOPPER	1	
8	90109-06M86-00	BOLT	1	
9	66M-44143-10-00	ROD, SHIFT	1	L
9	66M-44143-00-00	ROD, SHIFT	1	S
10	90170-06015-00	NUT	1	
11	95380-06700-00	NUT	1	
12	90468-18008-00	CLIP	1	
13	65W-44142-00-00	.JOINT	1	
14	90254-03M05-00	PIN, SPRING	1	
15	65W-44125-00-00	.LEVER, SHIFT ROD	1	
16	90387-06M29-00	COLLAR	1	
17	90201-06M31-00	.WASHER, PLATE	1	
18	97095-06025-00	BOLT	1	
19	92995-06600-00	WASHER	1	
20	66M-44192-00-00	.JOINT, ROD 1	1	
21	90201-05M06-00	.WASHER, PLATE	2	
22	90468-10005-00	CLIP	1	
23	90468-18008-00	CLIP	1	
24	65W-41638-00-00	PULLEY	1	
25	65W-41283-00-00	.LEVER, FREE ACCEL.	1	
26	661-41262-02-00	JOINT, CHOKE LEVER	1	
27	90387-06M08-00	COLLAR	1	
28	66M-41211-00-00	LINK, ACCEL.	1	
29	65W-14497-01-00	STAY, THROTTLE WIRE	1	
30	90201-06M31-00	.WASHER, PLATE	1	
31	97095-06055-00	BOLT	1	
32	92995-06600-00	WASHER	1	
33	97095-06010-00	BOLT	1	

Part Notes

F15ELHZ 2001 / CONTROL

PART NUMBER		NOTE TEXT
90468-18008-00		OEM: This part number is among the Top 100 Most Popular Marine Maintenance Parts as of March 2014.
90468-18008-00		OEM: This part number is among the Top 100 Most Popular Marine Maintenance Parts as of March 2014.

©2014 Yamaha Motor Corporation, U.S.A. All rights reserved.

F15ELHZ 2001 / REMO-CON ATTACHMENT

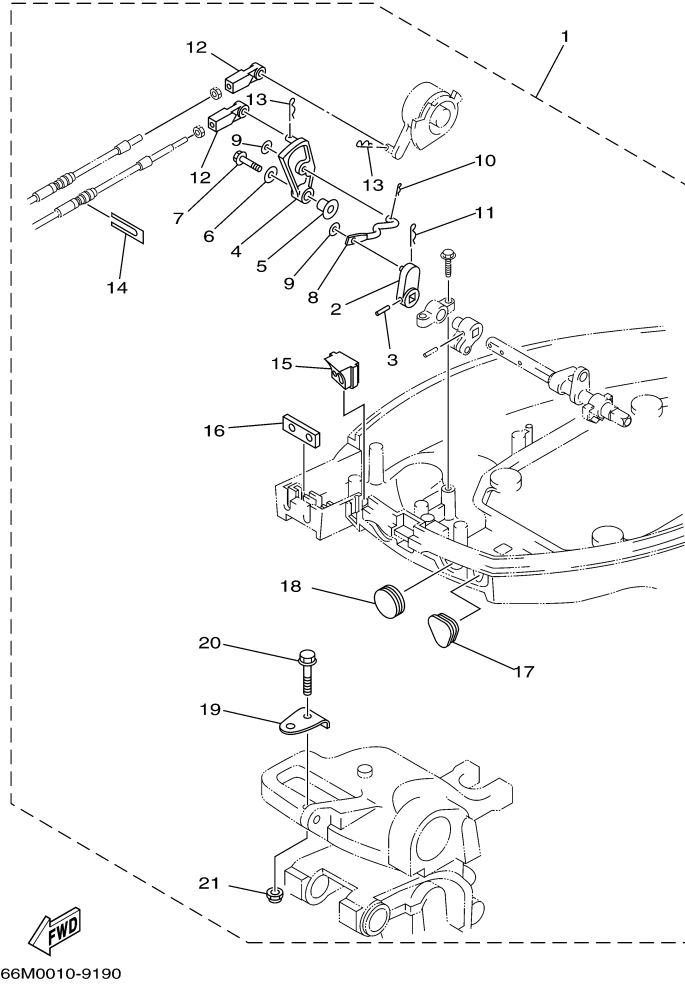



Part List

F15ELHZ 2001 / REMO-CON ATTACHMENT

REF - NO	PART NUMBER	PART NAME	QUANTITY	REMARKS
1	66M-48501-00-00	REMOTE CONT. ATTACHMENT ASSY.	1	AP
2	65W-44142-00-00	.JOINT	1	
3	90254-03M05-00	.PIN, SPRING	1	
4	65W-44125-00-00	.LEVER, SHIFT ROD	1	
5	90387-06M29-00	.COLLAR	1	
6	90201-06M31-00	.WASHER, PLATE	1	
7	97595-06525-00	.BOLT, WITH WASHER	1	
8	66M-44192-00-00	.JOINT, ROD 1	1	
9	90201-05M06-00	.WASHER, PLATE	2	
10	90468-10005-00	.CLIP	1	
11	90468-18008-00	.CLIP	1	
12	663-48344-00-00	.CABLE END, REMOTE CONTROL	2	
13	90468-18008-00	.CLIP	2	
14	6H3-48538-00-00	.CLAMP, CABLE 1	1	
15	66M-42725-20-00	.GROMMET	1	
16	62Y-42727-00-00	.GROMMET	1	
17	65W-26326-10-00	.GROMMET	1	
18	65W-42726-10-00	.GROMMET	1	
19	63V-48511-01-00	.HOOK, STEERING	1	
20	97575-08535-00	.BOLT, WITH WASHER	1	
21	90185-08057-00	.NUT, SELF-LOCKING	1	

Part Notes

F15ELHZ 2001 / REMO-CON ATTACHMENT

PART NUMBER		NOTE TEXT
90468-18008-00		OEM: This part number is among the Top 100 Most Popular Marine Maintenance Parts as of March 2014.
90468-18008-00		OEM: This part number is among the Top 100 Most Popular Marine Maintenance Parts as of March 2014.

©2014 Yamaha Motor Corporation, U.S.A. All rights reserved.

F15ELHZ 2001 / BRACKET 1

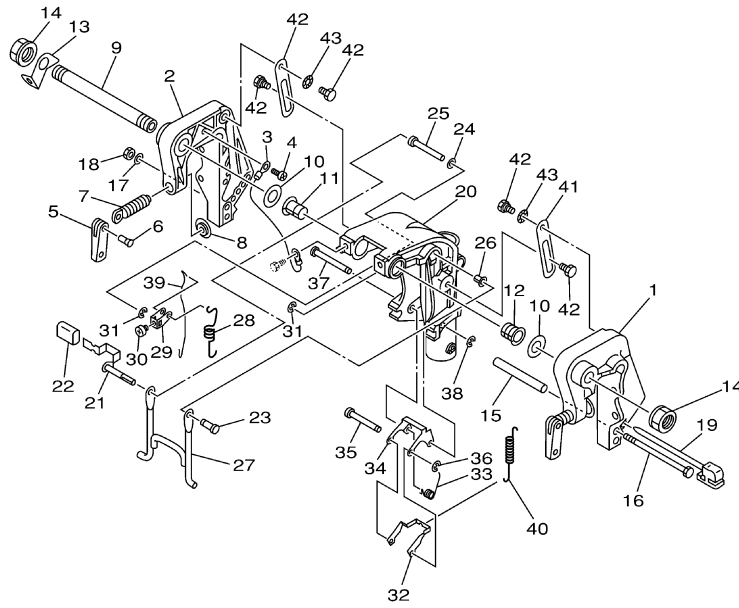

66M0110-1210

Part List

F15ELHZ 2001 / BRACKET 1

REF - NO	PART NUMBER	PART NAME	QUANTITY	REMARKS
1	63V-43111-05-4D	BRACKET, CLAMP	1	
2	63V-43112-06-4D	BRACKET, CLAMP	1	
3	66M-82148-00-00	WIRE, LEAD 4	1	
4	97885-06008-00	SCREW, PAN HEAD	1	
5	6E0-43118-01-00	HANDLE, TRANSOM CLAMP	2	
6	90243-04M01-00	PIN	2	
7	6E7-43116-00-00	SCREW, TRANSOM CLAMP	2	
8	648-43114-01-00	PAD, TRANSOM CLAMP	2	
9	63W-43131-00-00	BOLT, CLAMP BRACKET	1	
10	90202-22M54-00	WASHER, PLATE	2	
11	90386-22M94-00	BUSH	1	
12	90386-22M94-00	BUSH	1	
13	66R-43113-00-00	PLATE, CLAMP BRACKET	1	
14	63V-43145-00-00	CAP, CLAMP BRACKET	2	
15	90387-06M13-00	COLLAR	1	
16	90101-06M29-00	BOLT	1	
17	92995-06600-00	WASHER	1	
18	95380-06700-00	NUT	1	
19	6L2-43160-00-00	TILT ROD ASSY	1	
20	63V-43311-03-4D	BRACKET, SWIVEL 1	1	S
20	66M-43311-10-4D	BRACKET, SWIVEL 1	1	L
21	66M-43630-01-00	TILT LEVER ASSY	1	
22	682-43318-01-00	COVER	1	
23	63V-43191-00-00	SHAFT, STOPPER	1	
24	90202-07M60-00	WASHER, PLATE	1	
25	90387-07M07-00	COLLAR	1	
26	90386-07M95-00	BUSH	1	
27	66M-43350-01-00	RECEIVER ASSY	1	
28	90507-20M00-00	SPRING, TENSION	1	
29	63V-43641-01-00	LEVER, TILT	1	
30	90149-05M17-00	SCREW	1	
31	99080-05600-00	CIRCLIP	1	
32	66R-43614-00-00	PLATE, TILT LOCK	1	
33	90508-18M41-00	SPRING, TORSION	1	
34	66R-43615-00-00	PLATE, TILT LOCK	1	
35	66R-43611-00-00	SHAFT, TILT LOCK	1	
36	93430-04M03-00	CIRCLIP	1	
37	63V-43659-00-00	SHAFT, REVERSE LOCK	1	
38	99080-05600-00	CIRCLIP	1	
39	66R-43617-00-00	ROD, TILT LOCK	1	
40	90506-26M38-00	SPRING, TENSION	1	
41	63V-43181-00-00	LEVER, TILT STOP	2	
42	90109-06M84-00	BOLT	4	
43	90206-10M24-00	WASHER, WAVE	2	

F15ELHZ 2001 / BRACKET 2

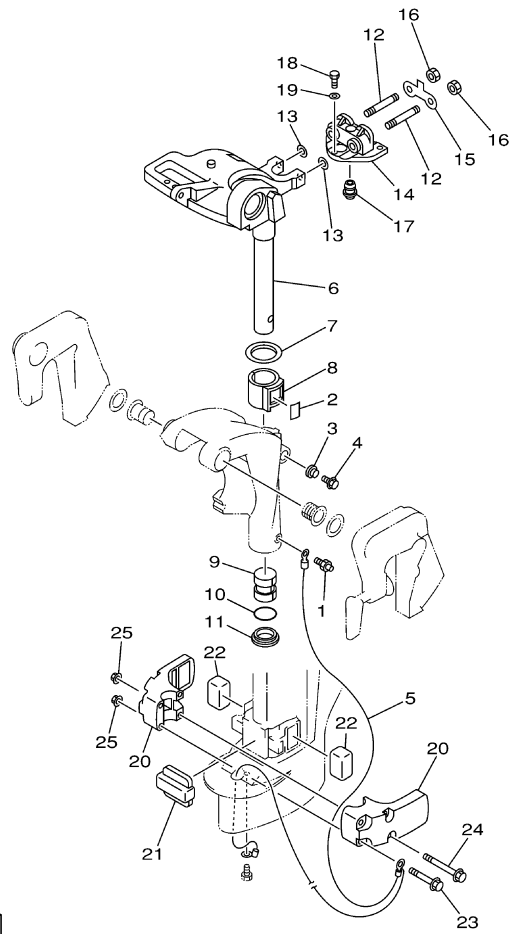

66M0010-1220

Part List

F15ELHZ 2001 / BRACKET 2

REF - NO	PART NUMBER	PART NAME	QUANTITY	REMARKS
1	93700-06M03-00	NIPPLE, GREASE	1	
2	63V-42528-00-00	PLATE, FRICTION	1	
3	689-43373-01-00	SEAL, DAMPER	1	
4	90105-06M07-00	.BOLT, FLANGE	1	
5	66M-82127-00-00	WIRE, LEAD 2	1	
6	66M-42511-11-4D	BRACKET, STEERING	1	L
6	66M-42511-01-4D	BRACKET, STEERING	1	S
7	90209-40008-00	WASHER	1	
8	65F-42537-00-00	BUSHING, PIVOT SHAFT	1	
9	90386-30048-00	BUSH	1	
10	93210-29M94-00	O-RING	1	
11	90386-30M60-00	BUSH	1	
12	90116-08M54-00	BOLT, STUD	2	
13	90201-08M06-00	WASHER, PLATE	2	
14	66M-44514-00-4D	MOUNT DAMPER, UPPER SIDE	1	
15	66M-44526-00-00	PLATE	1	
16	95380-08600-00	NUT	2	
17	66M-44366-00-00	DAMPER, WATER SEAL	1	
18	97075-06025-00	BOLT	3	
19	92995-06600-00	WASHER	3	
20	66M-44551-00-4D	HOUSING, LOWER MOUNT RUBBER	2	
21	66M-44557-00-00	MOUNT DAMPER, LOWER FRONT	1	
22	682-44555-30-00	MOUNT DAMPER, LOWER SIDE	2	
23	90119-08M45-00	BOLT, WITH WASHER	2	
24	90119-08M46-00	BOLT, WITH WASHER	2	
25	90179-08M34-00	NUT	4	

F15ELHZ 2001 / UPPER CASING

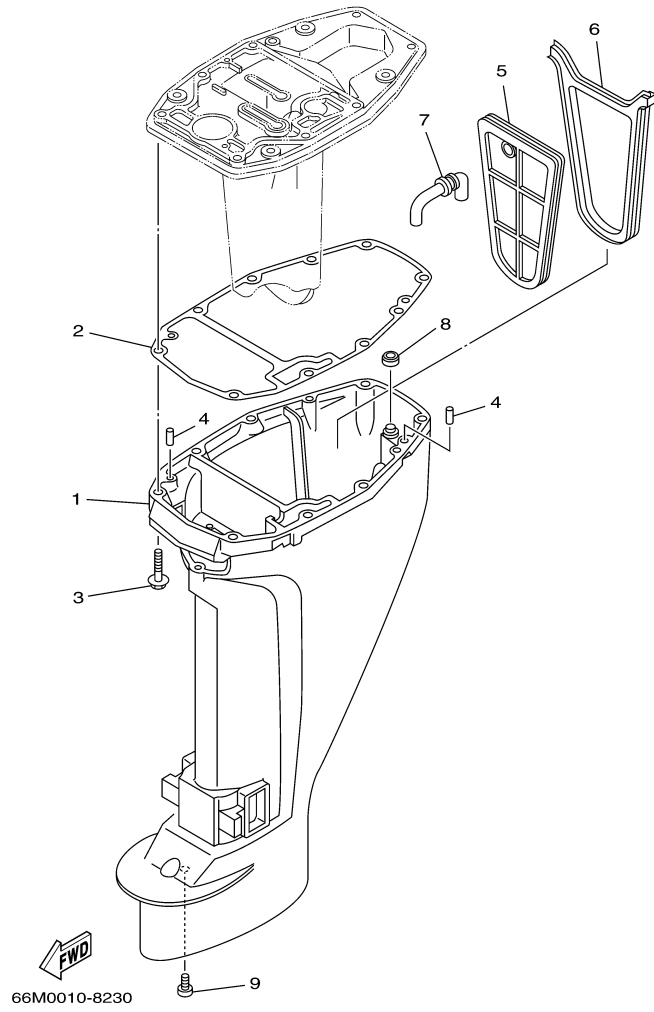

©2014 Yamaha Motor Corporation, U.S.A. All rights reserved.

Part List

F15ELHZ 2001 / UPPER CASING

REF - NO	PART NUMBER	PART NAME	QUANTITY	REMARKS
1	66M-45111-10-4D	CASING, UPPER	1	L
1	66M-45111-00-4D	CASING, UPPER	1	S
2	66M-45113-00-00	.GASKET, UPPER CASING	1	
3	97575-08545-00	BOLT, WITH WASHER	6	
4	93606-12019-00	.PIN, DOWEL	2	
5	66M-45126-00-00	PLATE, SEAL DAMPER	1	
6	66M-45115-00-00	.GASKET, UPPER CASING	1	
7	66M-45136-00-00	PIPE	1	
8	66M-45128-00-00	.SEAL 2	1	
9	90157-06M06-00	SCREW, PAN HEAD	1	

F15ELHZ 2001 / OIL PAN

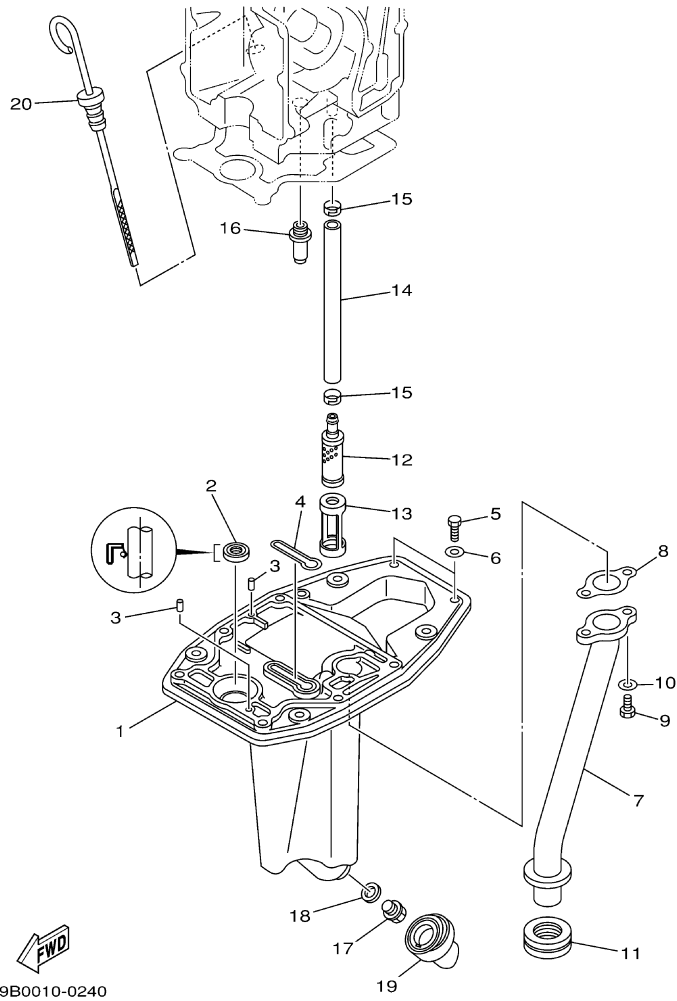

Part List

F15ELHZ 2001 / OIL PAN

REF - NO	PART NUMBER	PART NAME	QUANTITY	REMARKS
1	66M-41137-00-5B	GUIDE, EXHAUST	1	
2	93101-12M63-00	.OIL SEAL	1	
3	93606-12019-00	.PIN, DOWEL	2	
4	66M-11355-00-00	SEAL, CYLINDER 1	1	
5	97095-06020-00	BOLT	2	
6	92995-06600-00	WASHER	2	
7	66M-41131-01-94	MANIFOLD, EXT. 1	1	
8	66M-41133-00-00	.GASKET, EXHAUST MANIFOLD 1	1	
9	97095-06016-00	BOLT	2	
10	92995-06600-00	WASHER	2	
11	66M-41138-00-00	.SEAL, EXT. 1	1	
12	66M-13421-00-00	STRAINER 2	1	
13	66M-13417-00-00	COVER, STRAINER	1	
14	66M-13416-00-00	PIPE, OIL 1	1	
15	66M-24351-00-00	BAND 1	2	
16	6G8-11575-00-00	RELIEF VALVE ASSY	1	
17	90340-14M06-00	PLUG, STRAIGHT SCREW	1	
18	90430-14M09-00	.GASKET	1	
19	66M-15316-00-00	DAMPER, ENGINE MOUNT 1	1	
20	66M-15362-00-00	PLUG, OIL LEVEL	1	

Part Notes

F15ELHZ 2001 / OIL PAN

PART NUMBER	NOTE TEXT
90430-14M09-00 	OEM: This part number is among the Top 100 Most Popular Marine Maintenance Parts as of March 2014.

©2014 Yamaha Motor Corporation, U.S.A. All rights reserved.

F15ELHZ 2001 / LOWER CASING DRIVE 1

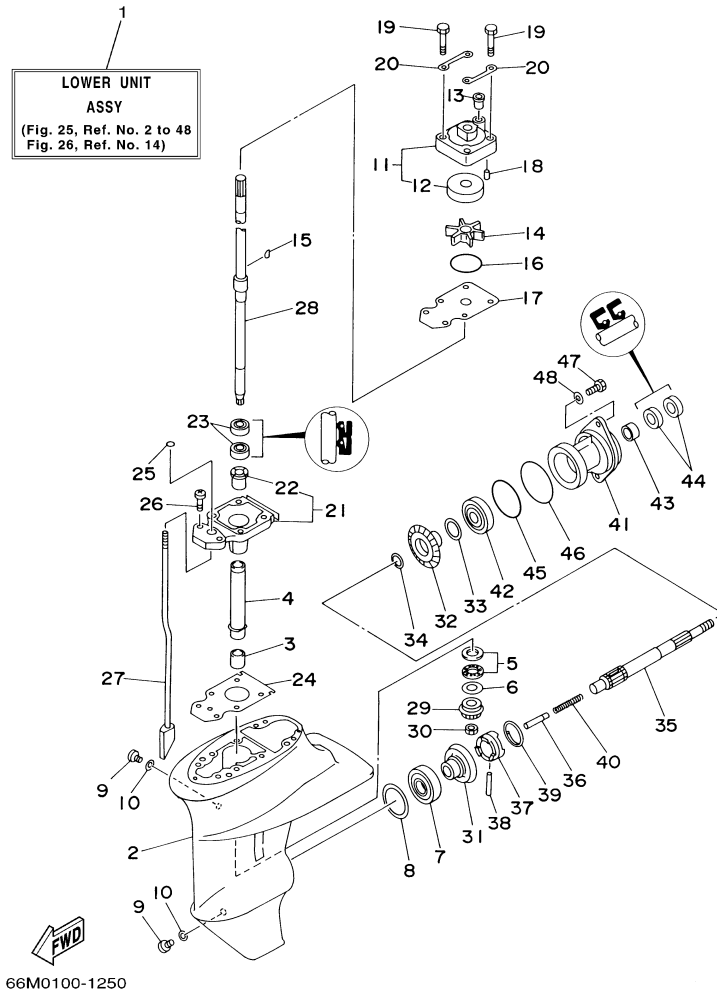

©2014 Yamaha Motor Corporation, U.S.A. All rights reserved.

Part List

F15ELHZ 2001 / LOWER CASING DRIVE 1

REF - NO	PART NUMBER	PART NAME	QUANTITY	REMARKS
1	66M-45300-11-4D	LOWER UNIT ASSY	1	L
1	66M-45300-01-4D	LOWER UNIT ASSY	1	S
2	66M-45311-00-4D	CASING, LOWER	1	S
2	63V-45311-01-4D	CASING, LOWER	1	L
3	93315-314V8-00	BEARING	1	
4	63V-45536-00-00	SLEEVE, DRIVE SHAFT	1	
5	93341-41414-00	BEARING	1	
6	6E8-45587-10-20	SHIM (T:1.20MM)	1	UR
6	6E8-45587-10-13	SHIM (T:1.13MM)	1	UR
7	93332-00005-00	BEARING	1	
8	664-45567-01-12	SHIM (T:0.12MM)	1	UR
8	664-45567-01-30	SHIM (T:0.30MM)	1	UR
8	664-45567-01-50	SHIM (T:0.50MM)	1	UR
8	664-45567-01-40	SHIM (T:0.40MM)	1	UR
8	664-45567-01-15	SHIM (T:0.15MM)	1	UR
8	664-45567-01-18	SHIM (T:0.18MM)	1	UR
8	664-45567-01-10	SHIM (T:0.10MM)	1	UR
9	90340-08M04-00	PLUG, STRAIGHT SCREW	2	
10	90430-08020-00	.GASKET	2	
11	63V-44301-00-00	WATER PUMP HOUSING COMP.	1	
12	63V-44322-00-00	.INSERT, CARTRIDGE	1	
13	647-44366-00-00	.DAMPER, WATER SEAL	1	
14	63V-44352-01-00	.IMPELLER	1	
15	664-44338-00-00	.KEY, WOODRUFF	1	
16	93210-44398-00	.O-RING	1	
17	63V-44323-00-00	.OUTER PLATE, CARTRIDGE	1	
18	93604-12M07-00	PIN, DOWEL	2	
19	97080-08045-00	BOLT	4	
20	63V-44328-00-00	PLATE	2	
21	63V-45331-00-5B	HOUSING, BEARING	1	
22	90381-14020-00	.BUSH, SOLID	1	
23	93101-20048-00	.OIL SEAL	2	
24	63V-45315-A0-00	.PACKING, LOWER CASING	1	
25	93210-06ME6-00	.O-RING	1	
26	97080-08025-00	BOLT	2	
27	66M-44150-10-00	SHIFT CAM ASSY	1	L
27	63V-44150-00-00	SHIFT CAM ASSY	1	S
28	63V-45510-11-00	DRIVE SHAFT ASSY	1	L
28	63V-45510-01-00	DRIVE SHAFT ASSY	1	S
29	63V-45551-00-00	PINION (13T)	1	
30	90179-08M06-00	NUT	1	
31	6E7-45560-01-00	GEAR 1 (27T)	1	
32	6E7-45571-00-00	GEAR 2 (27T)	1	
33	626-45577-00-01	SHIM (T:0.10MM)	1	UR
33	626-45577-00-05	SHIM (T:0.50MM)	1	UR
33	626-45577-00-03	SHIM (T:0.30MM)	1	UR
34	90201-17682-00	WASHER, PLATE	1	
35	683-45611-00-00	SHAFT, PROPELLER	1	
36	650-45635-00-00	PLUNGER, SHIFT	1	
37	682-45631-00-00	CLUTCH, DOG	1	
38	90250-05010-00	PIN, STRAIGHT	1	
39	648-45633-00-00	RING, CROSS PIN	1	
40	90501-14M06-00	SPRING, COMPRESSION	1	
41	683-45361-02-4D	CAP, LOWER CASING	1	
42	93306-00501-00	BEARING	1	
43	93315-317U2-00	BEARING	1	
44	93101-17054-00	.OIL SEAL	2	
45	93210-57M09-00	.O-RING	1	
46	93210-56M80-00	.O-RING	1	

47	97095-06020-00	BOLT	2
48	92995-06600-00	WASHER	2

Part Notes

F15ELHZ 2001 / LOWER CASING DRIVE 1

PART NUMBER		NOTE TEXT
90430-08020-00		OEM: This part number is among the Top 100 Most Popular Marine Maintenance Parts as of March 2014.

©2014 Yamaha Motor Corporation, U.S.A. All rights reserved.

F15ELHZ 2001 / LOWER CASING DRIVE 2

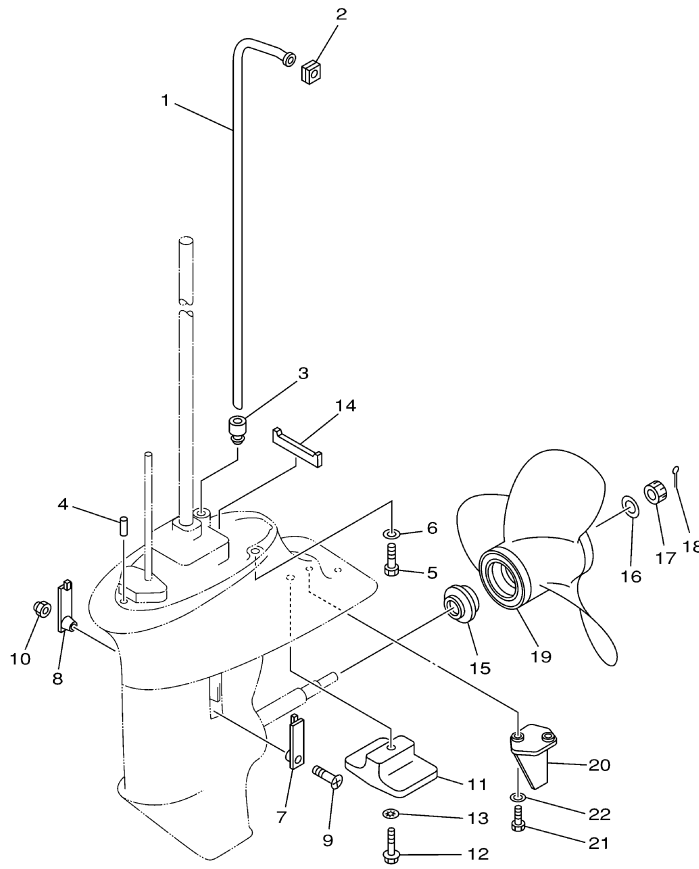

69A0300-0230

Part List

F15ELHZ 2001 / LOWER CASING DRIVE 2

REF - NO	PART NUMBER	PART NAME	QUANTITY	REMARKS
1	66M-44361-10-00	TUBE, WATER	1	L
1	66M-44361-00-00	TUBE, WATER	1	S
2	63V-44365-10-00	DAMPER, WATER SEAL 1	1	
3	63V-44368-00-00	.RUBBER, WATER SEAL 4	1	
4	93604-12M07-00	PIN, DOWEL	2	
5	97075-08030-00	BOLT	4	
6	92995-08600-00	WASHER	4	
7	6G1-45214-00-00	COVER, WATER INLET 1	1	
8	63V-45215-00-00	COVER, WATER INLET 2	1	
9	90152-05M04-00	SCREW, COUNTERSUNK	1	
10	90185-05002-00	NUT, NYLON	1	
11	61N-45251-00-00	ANODE	1	
12	95895-06030-00	BOLT, FLANGE	1	
13	92990-06300-00	WASHER, INTERNAL TOOTH	1	
14	63V-45375-00-00	DAMPER, SEAL	1	
15	6E7-45987-01-00	SPACER 1	1	
16	90201-10M01-00	WASHER, PLATE	1	
17	90171-10M01-00	NUT, CASTLE	1	
18	91490-30020-00	PIN. COTTER	1	
19	683-45943-00-EL	PROPELLER (3X9-1/4"X10-1/2"-J)	1	UR
19	683-45945-00-EL	PROPELLER (3X9-1/4"X9"-J)	1	UR
19	63V-45947-00-EL	PROPELLER (3X9-1/4"X8"-J)	1	UR
19	683-45941-00-EL	PROPELLER (3X9-1/4"X12"-J)	1	UR
19	683-45952-00-EL	PROPELLER (3X9-1/4"X9-3/4"-J)	1	UR
20	66M-45371-00-00	TAB-TRIM	1	S
21	97095-06016-00	BOLT	2	S
22	92995-06600-00	WASHER	2	S

F15ELHZ 2001 / REPAIR KIT 1

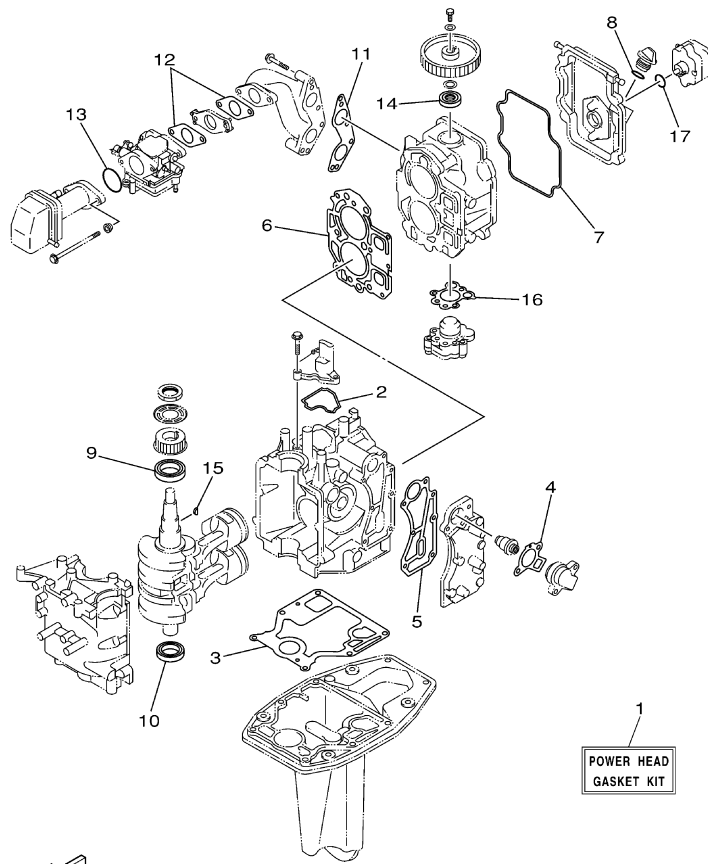

66M0100-1280

Part List

F15ELHZ 2001 / REPAIR KIT 1

REF - NO	PART NUMBER	PART NAME	QUANTITY	REMARKS
1	66M-W0001-01-00	POWER HEAD GASKET KIT	1	
2	66M-11357-00-00	.SEAL, CYLINDER 3	1	
3	66M-11351-00-00	.GASKET, CYLINDER	1	
4	62Y-12414-00-00	.GASKET, COVER	1	
5	66M-41114-00-00	.GASKET, EXHAUST OUTER COVER	1	
6	66M-11181-00-00	.GASKET, CYLINDER HEAD 1	1	
7	66M-11356-00-00	.SEAL, CYLINDER 2	1	
8	93210-24M79-00	.O-RING	1	
9	93102-35M51-00	.OIL SEAL	1	
10	93102-25M52-00	.OIL SEAL	1	
11	66M-13645-00-00	.GASKET, MANIFOLD 1	1	
12	66M-13646-00-00	.GASKET, MANIFOLD 2	2	
13	93210-35M86-00	.O-RING	1	
14	93102-18M21-00	.OIL SEAL	1	
15	90280-03M01-00	.KEY, WOODRUFF	1	
16	66M-13329-10-00	.GASKET, PUMP COVER	1	
17	93210-20M65-00	.O-RING	1	

Part Notes

F15ELHZ 2001 / REPAIR KIT 1

PART NUMBER	NOTE TEXT
62Y-12414-00-00 	OEM: This part number is among the Top 100 Most Popular Marine Maintenance Parts as of March 2014.

©2014 Yamaha Motor Corporation, U.S.A. All rights reserved.

F15ELHZ 2001 / REPAIR KIT 2

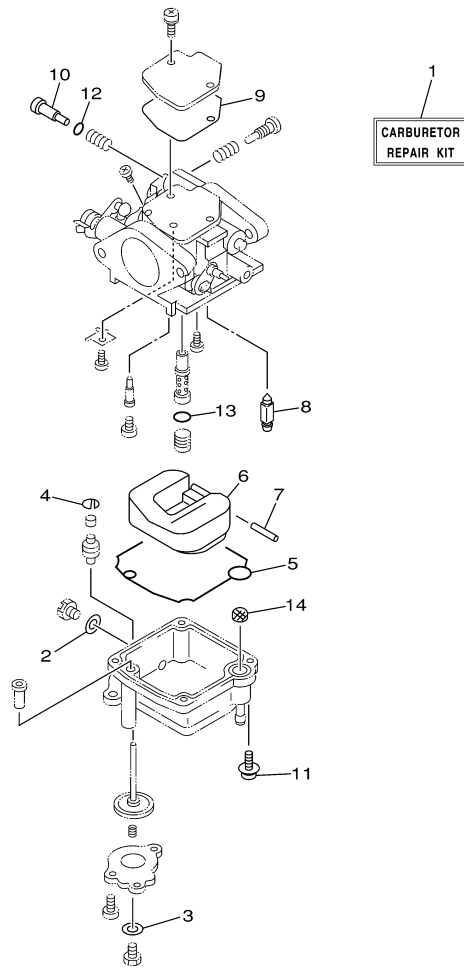



66M0100-8280

Part List

F15ELHZ 2001 / REPAIR KIT 2

REF - NO	PART NUMBER	PART NAME	QUANTITY	REMARKS
1	66M-W0093-00-00	CARBURETOR REPAIR KIT	1	
2	66M-14398-00-00	.GASKET	1	
3	6L2-14398-00-00	.GASKET	1	
4	66M-14377-00-00	.STOPPER	1	
5	66M-14384-00-00	.GASKET, FLOAT CHAMBER	1	
6	6L2-14385-00-00	.FLOAT	1	
7	6E5-14386-01-00	.PIN, FLOAT	1	
8	6L2-14392-00-00	.VALVE	1	
9	62Y-14399-00-00	.GASKET	1	
10	5H0-14323-00-00	.SCREW, AIR ADJUSTING	1	
11	97980-04112-00	.SCREW, WITH WASHER	4	
12	62Y-14397-00-00	.O-RING	1	
13	6F5-14397-00-00	.O-RING	1	
14	66M-14827-00-00	.FILTER	1	

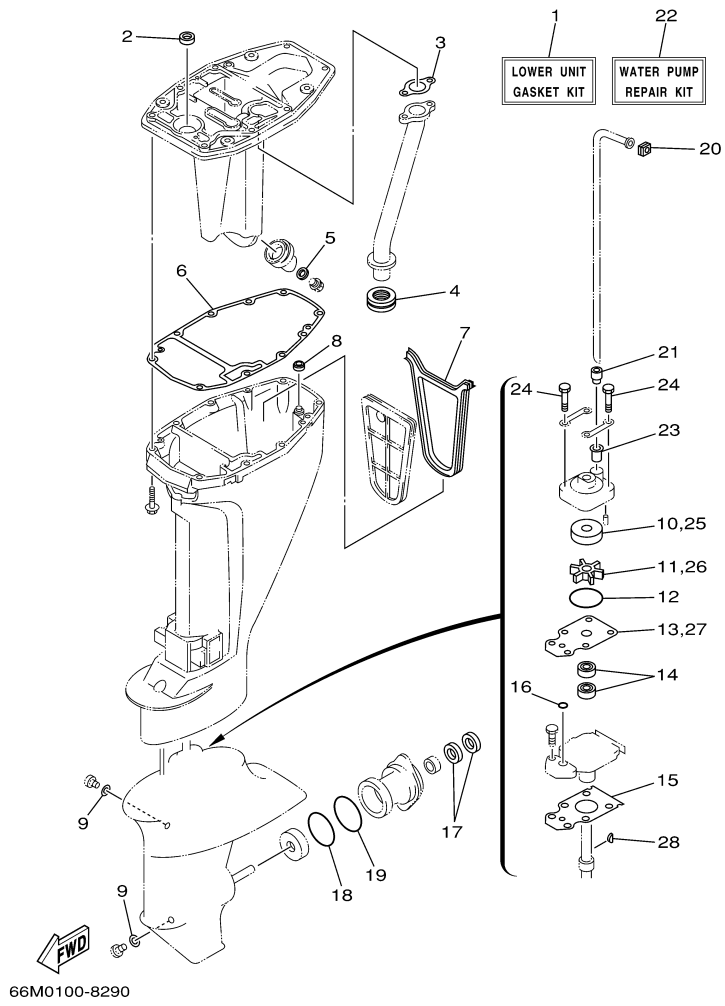
F15ELHZ 2001 / REPAIR KIT 3



©2014 Yamaha Motor Corporation, U.S.A. All rights reserved.



Part List

F15ELHZ 2001 / REPAIR KIT 3

REF - NO	PART NUMBER	PART NAME	QUANTITY	REMARKS
1	66M-W0001-20-00	LOWER UNIT GASKET KIT	1	
2	93101-12M63-00	.OIL SEAL	1	
3	66M-41133-00-00	.GASKET, EXHAUST MANIFOLD 1	1	
4	66M-41138-00-00	.SEAL, EXT 1	1	
5	90430-14M09-00	.GASKET	1	
6	66M-45113-00-00	.GASKET, UPPER CASING	1	
7	66M-45115-00-00	.GASKET, UPPER CASING	1	
8	66M-45128-00-00	.SEAL 2	1	
9	90430-08020-00	.GASKET	2	
10	63V-44322-00-00	.INSERT, CARTRIDGE	1	
11	63V-44352-00-00	.IMPELLER	1	
12	93210-44398-00	.O-RING	1	
13	63V-44323-00-00	.OUTER PLATE, CARTRIDGE	1	
14	93101-20048-00	.OIL SEAL	2	
15	63V-45315-A0-00	.PACKING, LOWER CASING	1	
16	93210-06ME6-00	.O-RING	1	
17	93101-17054-00	.OIL SEAL	2	
18	93210-57M09-00	.O-RING	1	
19	93210-56M80-00	.O-RING	1	
20	63V-44365-10-00	.DAMPER, WATER SEAL 1	1	
21	63V-44368-00-00	.RUBBER, WATER SEAL 4	1	
22	63V-W0078-00-00	WATER PUMP REPAIR KIT	1	
23	647-44366-00-00	.DAMPER, WATER SEAL	1	
24	97080-08045-00	.BOLT	4	
25	63V-44322-00-00	.INSERT, CARTRIDGE	1	
26	63V-44352-01-00	.IMPELLER	1	
27	63V-44323-00-00	.OUTER PLATE, CARTRIDGE	1	
28	664-44338-00-00	.KEY, WOODRUFF	1	

Part Notes

F15ELHZ 2001 / REPAIR KIT 3

PART NUMBER		NOTE TEXT
90430-14M09-00		OEM: This part number is among the Top 100 Most Popular Marine Maintenance Parts as of March 2014.
90430-08020-00		OEM: This part number is among the Top 100 Most Popular Marine Maintenance Parts as of March 2014.

©2014 Yamaha Motor Corporation, U.S.A. All rights reserved.

©2014 Yamaha Motor Corporation, U.S.A. All rights reserved.