

V8-350-CE-D, V8-380-CE-D, V8-430-CE-D

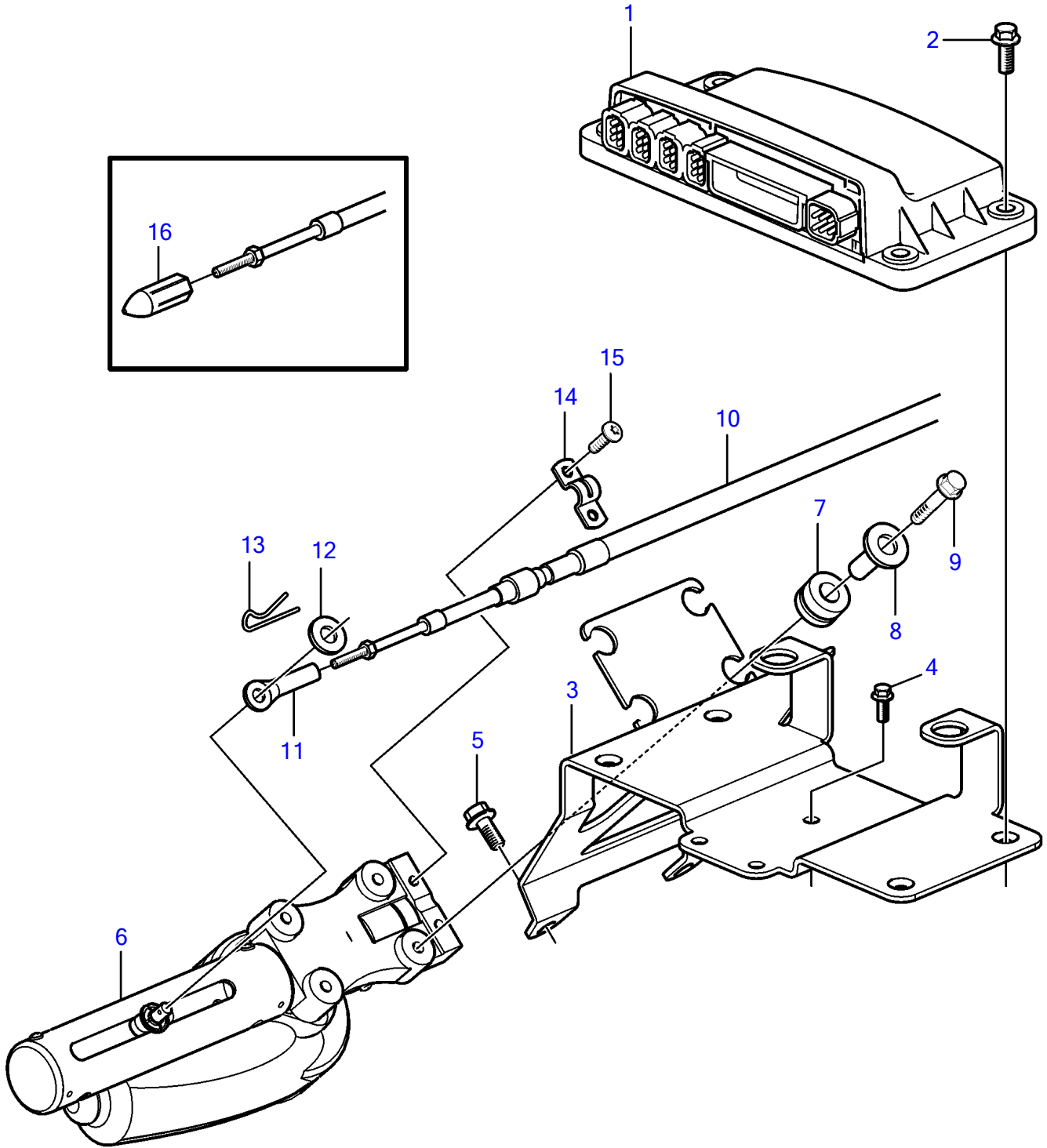

V8-350-CE-D, V8-380-CE-D, V8-430-CE-D

| REF | PART NO. | QTY | DESCRIPTION | NOTES |
|-----|----------|-----|----------------------|---|
| 1 | 21722888 | 1 | Power train control | |
| | 3586266 | X | Software | Vodia-programming. This p/n can not be ordered, but will be used for invoicing. |
| | 3586267 | X | Software | Warehouse programming. This p/n can not be ordered, but will be used for invoicing. |
| 2 | 3595494 | 4 | Screw | |
| 3 | | 1 | Bracket | |
| 4 | 946544 | 3 | Flange screw | |
| 5 | 947542 | 2 | Flange screw | |
| 6 | 3848712 | 1 | Shift motor | |
| 7 | 3594888 | 4 | Vibration damper | |
| 8 | 3594890 | 4 | Sleeve | |
| 9 | 3843651 | 4 | Flange screw | |
| 10 | 3594991 | 1 | Cable | |
| 11 | 3850941 | 1 | Adapter | |
| 12 | 940191 | 1 | Washer | |
| 13 | 17253 | 1 | Split pin | |
| 14 | 21144647 | 1 | Bracket | |
| 15 | 973155 | 2 | 6 point socket screw | |
| 16 | 40005050 | 1 | Guide | |