

V8-320-C-B

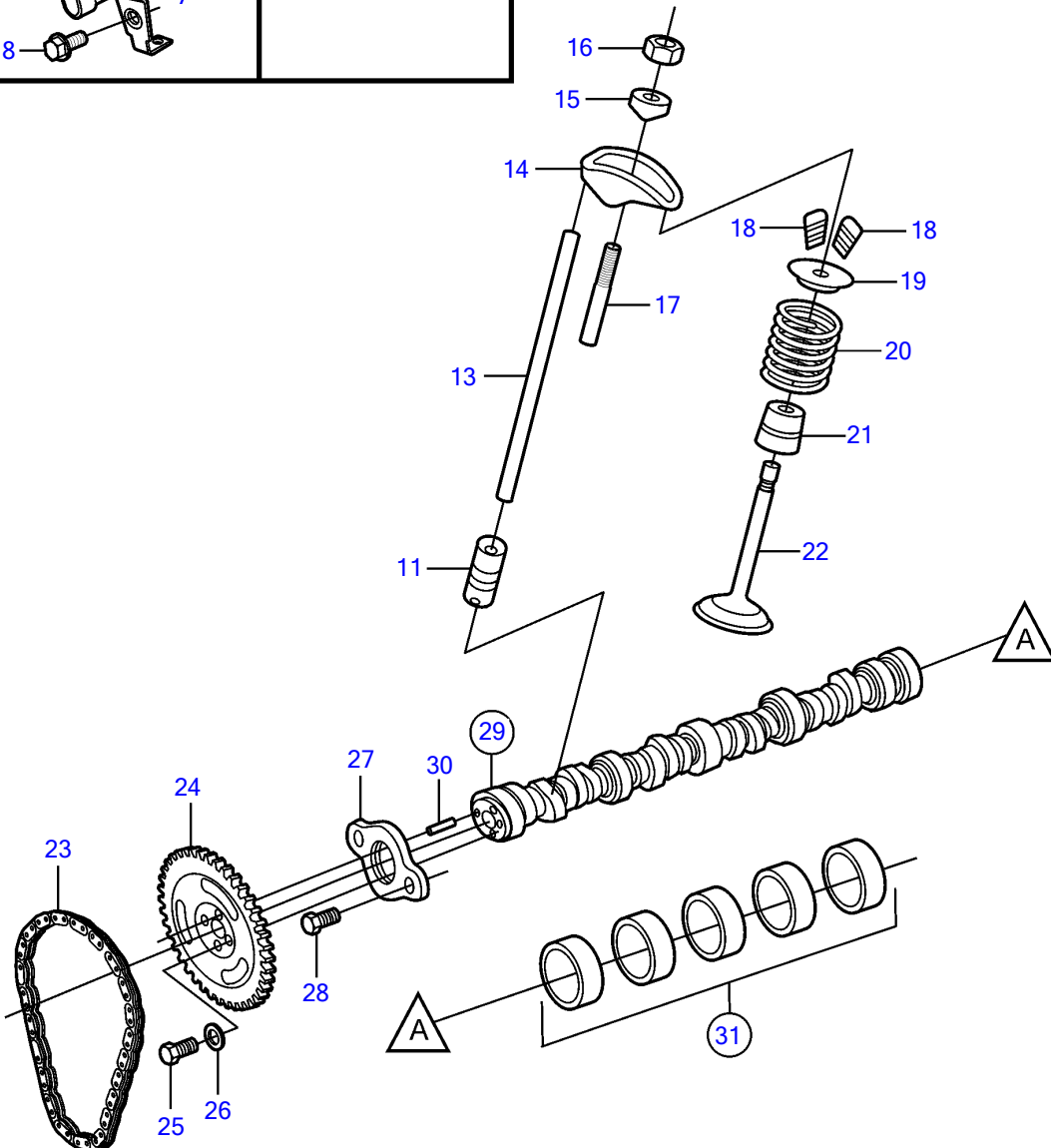
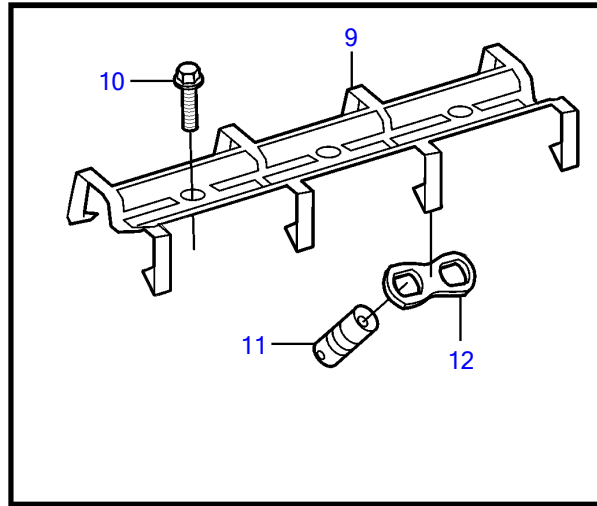
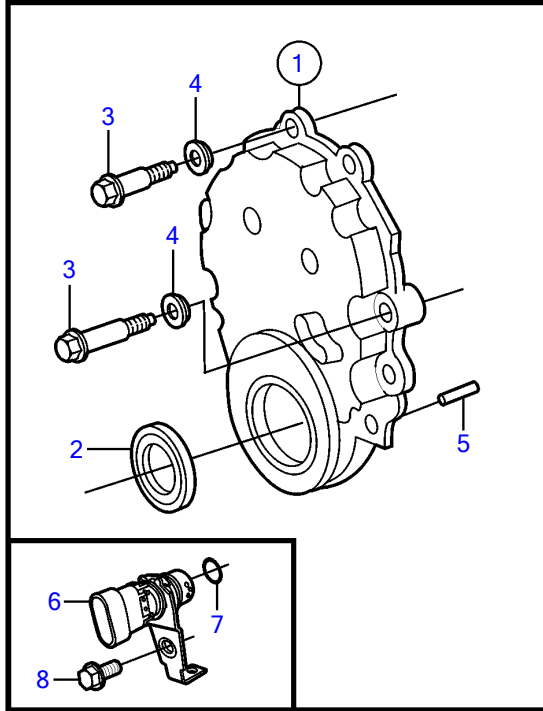

V8-320-C-B

REF	PART NO.	QTY	DESCRIPTION	NOTES
1	3862263	1	Timing gear cover	
		1	• Gasket	not sold separately
2	3862262	1	• Sealing	
3	(3855736)	2	Screw	Obsolete part
	3855737	6	Screw	
4	3855739	8	Grommet	
5	3855972	2	Pin	
6	3858979	1	Sensor	
7	3859009	1	O-ring	
8	3858983	1	Bolt	
9	3856144	1	Retainer	
10		3	Screw	part not sold
11	3856127	16	Tappet	
12	3856139	8	Guide	
13	3863058	16	Push rod	
14	3861167	1	Rocker arm, roller	Set of 16
15		16	• Ball	not sold separately
16		16	• Nut	not sold separately
17	(3853146)	1	Stud	Obsolete part, O.S=0.003" (0.076mm)
	(3853147)	1	Stud	Obsolete part, O.S=.013" (0.330mm)
18	3855823	32	Valve cotter	
19	3855816	16	Valve cap	
20	21110962	1	Valve spring	Set of 16, replaced by next part number
	21605360	1	Valve spring	Set of 16
21	3855814	8	Valve stem seal	Intake
	3862362	8	Valve stem seal	Exhaust
22	3855810	8	Valve, intake	Standard
	3855808	8	Valve, exhaust	Standard
23	3852685	1	Chain	
24	3856114	1	Sprocket	
25	3853173	3	Bolt	
26	3856151	3	Washer	
27	3855998	1	Retainer	
28	3853172	2	Screw	
29	3856119	1	Camshaft	
30	3855972	1	• Pin	
31	(3856162)	1	Kit	Obsolete part