

5.7GiC-300-J, 5.7GiC-300-JF, 5.7GXiC-J, 5.7GXiC-JF

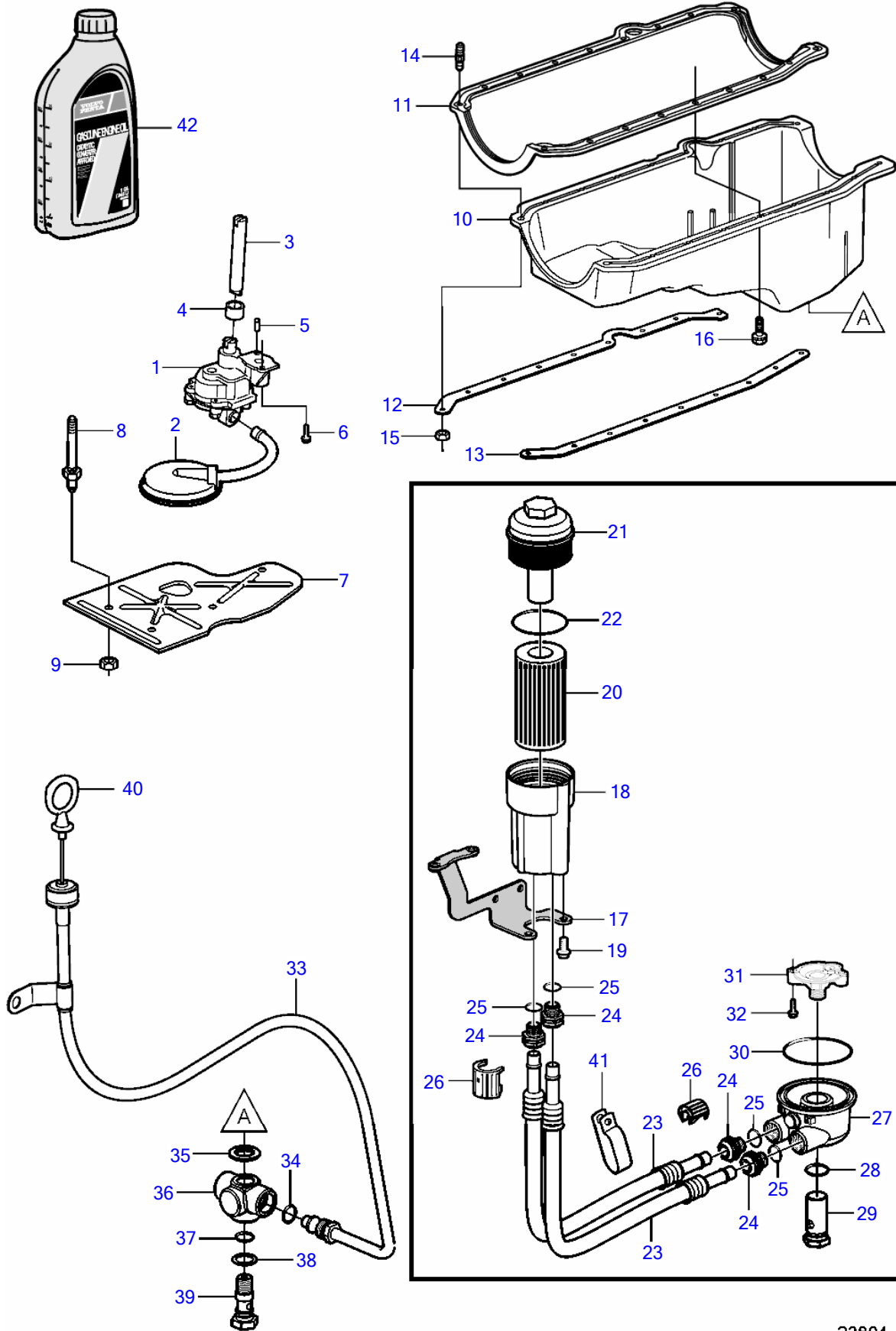

23804

5.7GiC-300-J, 5.7GiC-300-JF, 5.7GXIC-J, 5.7GXIC-JF

REF	PART NO.	QTY	DESCRIPTION	SEE SEC.	NOTES
1	3856125	1	Oil pump		
2	3856126	1	Strainer		
3	3853198	1	Shaft		
4	3853199	1	Retainer		
5	3855972	2	Pin		
6	3853234	1	Bolt		
7	3852744	1	Baffle		
8	3862354	6	Stud		
9	3857664	5	Nut		
10	3857778	1	Sump		
11	3856138	1	Gasket kit		
12	3856121	1	Reinforcement		Starboard
13	3856120	1	Reinforcement		Port
14	3853202	4	Stud		
15	3856930	4	Nut		
16	3852595	14	Bolt		
17	40005662	1	Bracket		
18	3886659	1	Oil reservoir		
19	3595499	2	Flange screw		
20	8692305	1	Oil filter		
21	3875234	1	Cardboard tube		
22		1	• O-ring		Not sold separately
23	3887657	2	Hose assembly		
24	3886181	4	Fitting screw		
25		4	• O-ring		Not sold separately
26	3888543	4	Clip		
27	3886019	1	Adapter		
28	3852089	1	O-ring		
29	3853495	1	Retainer		
30	3852470	1	O-ring		
31	(3852219)	1	Valve		Obsolete part
32	3852133	2	Screw		
33	3595311	1	Dipstick tube		
34	3852033	1	O-ring		
35	3851981	1	Washer		
36	3587783	1	Fitting		
37	3853674	1	O-ring		
38	3852007	1	Washer		
39	888958	1	Retainer		
40	21107444	1	Dipstick		
41	3860075	1	Attaching clamp		
42		X	Oil	36094	For current oil part numbers, follow link to "Maintenance Parts" page.