

5.8FIIHUBCE, 5.8FIIHUECE, 5.8FIPHUBCE, 5.8FIPHUCCE, 5.8FIPHUECE, 5.8FIPHURCE, 5.8FIPHUSCE, 5.8FLIHUB, 5.8FLIHUE, 5.8FLPHUB, 5.8FLPHUC, 5.8FLPHUE, 5.8FLPHUR, 5.8FLPHUS, 5.8FSIPHUBCE, 5.8FSIPHUCCE, 5.8FSIPHUECE, 5.8FSIPHURCE, 5.8FSIPHUSCE

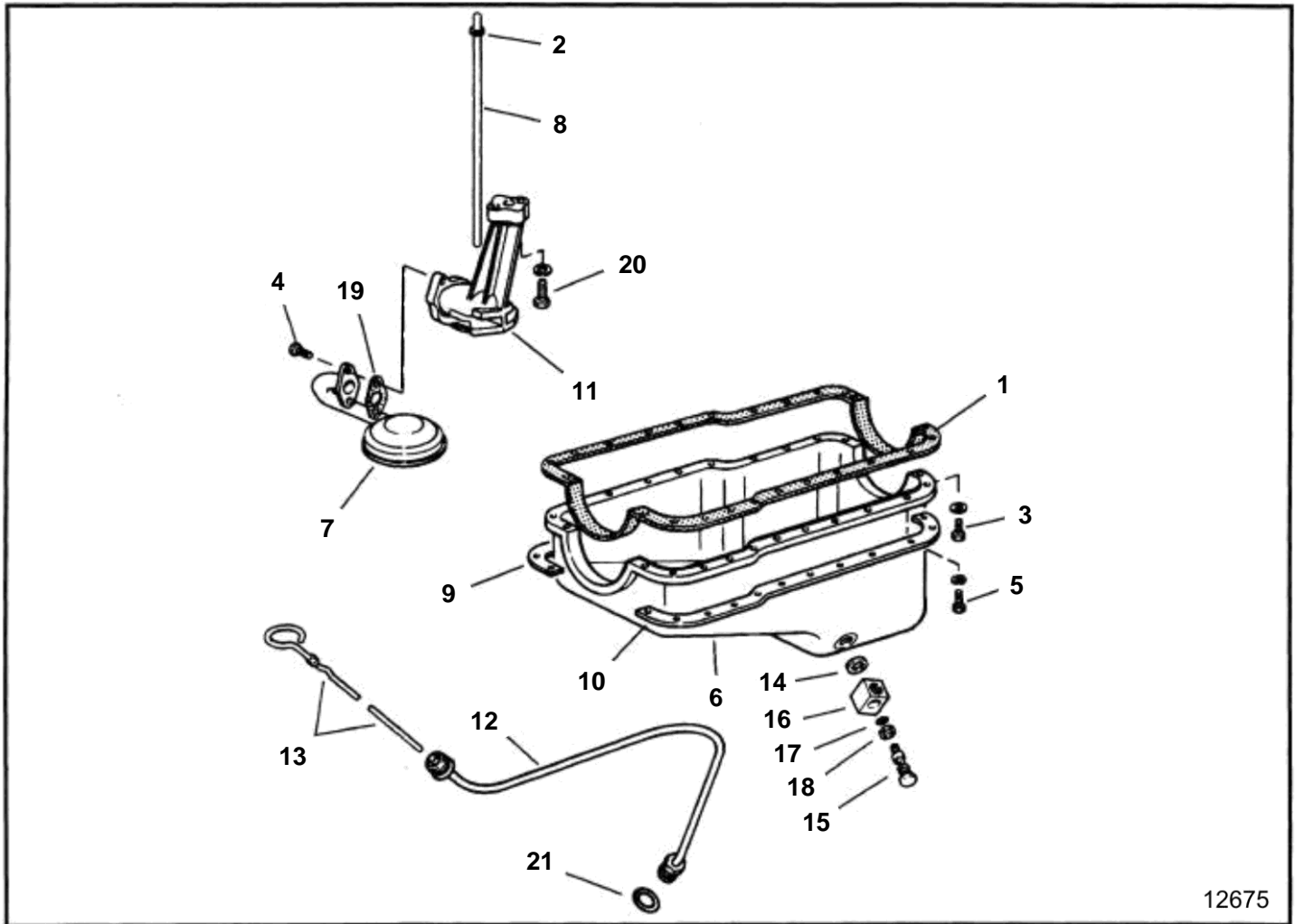

12675

5.8FIIHUBCE, 5.8FIIHUECE, 5.8FIPHUBCE, 5.8FIPHUCCE, 5.8FIPHUECE, 5.8FIPHURCE, 5.8FIPHUSCE, 5.8FLIHUB, 5.8FLIHUE, 5.8FLPHUB, 5.8FLPHUC, 5.8FLPHUE, 5.8FLPHUR, 5.8FLPHUS, 5.8FSIPHUBCE, 5.8FSIPHUCCE, 5.8FSIPHUECE, 5.8FSIPHURCE, 5.8FSIPHUSCE

REF	PART NO.	QTY	DESCRIPTION
1	3852823	1	Gasket, Oil pan
2	3853005	1	Retainer, Oil pump shaft
3	3853006	4	Screw, Oil pan
4	3853032	2	Screw, Pickup tube
5	3853033	18	Screw, Oil pan
6		1	Sump
7	3853104	1	Oil strainer
8	3853105	1	Shaft, Oil pump
9	3853106	1	Reinforcement, Oil pan, starboard
10	3853107	1	Reinforcement, Oil pan, port
11	3853908	1	Pump
12	3854170	1	Tube, Oil dipstick
13	3850473	1	Gauge
14	3853725	1	Washer
15	3852609	1	Retainer, Oil pan drain
16	3855112	1	Fitting, Oil pan drain
17	3853674	1	O-ring, Retainer, oil pan drain
18	3852007	1	Washer, Retainer, oil pan drain
19	3853267	1	Gasket, Screen to oil pump
20	3852788	2	Bolt, Oil pump to block
21	3852033	1	O-ring, Oil gage tube to fitting