

TMD122A

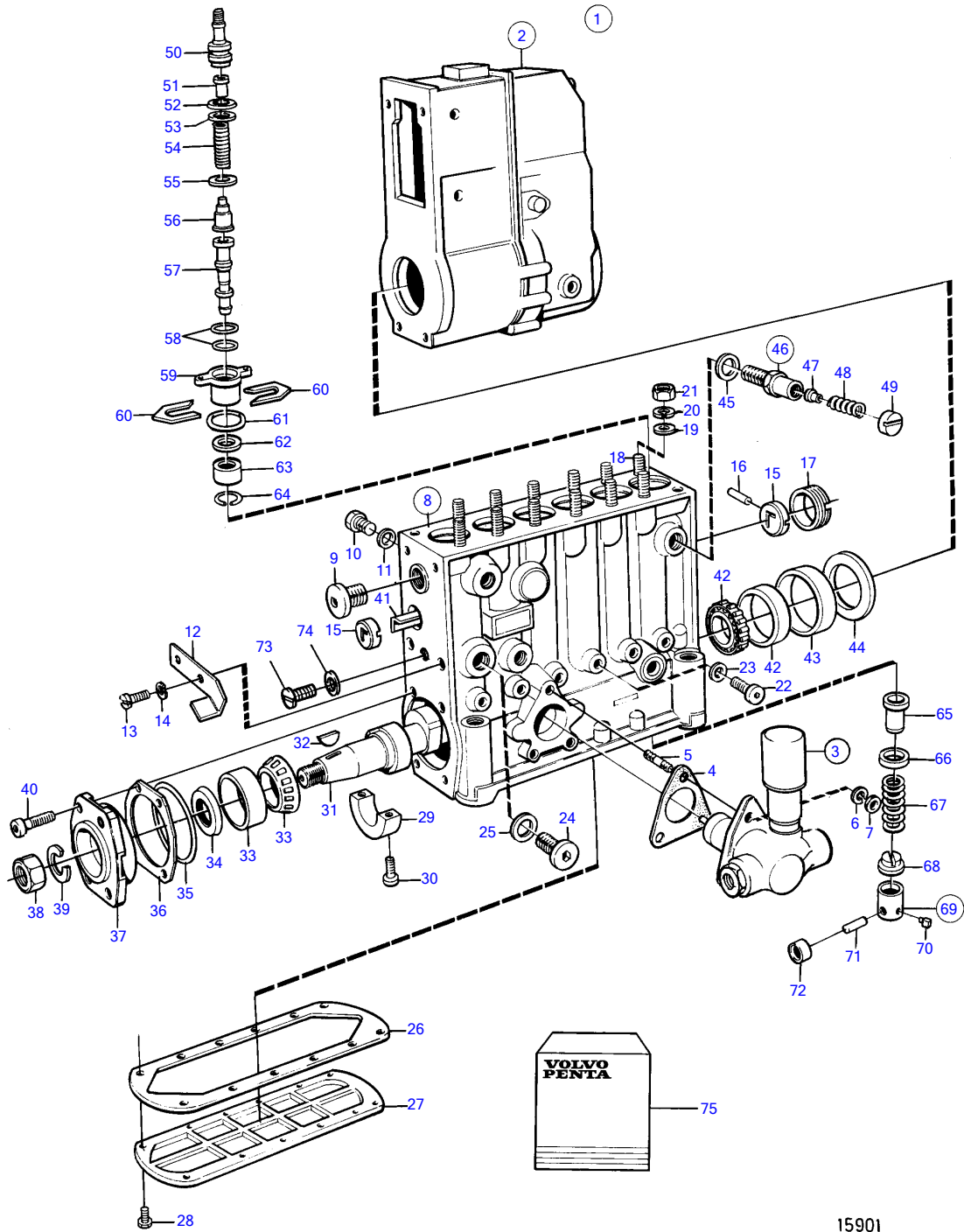

15901

TMD122A

REF	PART NO.	QTY	DESCRIPTION	SEE SEC.	NOTES
1	863094	1	Injection pump		Repl by 3826532
2	(864084)	1	• Governor		Obsolete part
			•	2122	
			•	2128	
			•	6039	
3	244825	1	• Feed pump		
			• •	2092	
4	863370	1	• Gasket		
5	(130673)	3	• Stud		Obsolete part
6	949607	3	• Spring washer		
7	940197	3	• Hexagon nut		
8		1	• Housing		
9	(844988)	1	• Plug		Obsolete part
10	847439	1	• Screw		
11	969011	1	• Gasket		
12	(241647)	1	• Turn signal		Obsolete part
13	956092	2	• Cross recessed screw		
14	949607	2	• Spring washer		
15	(240014)	2	• Bushing		Obsolete part
16	(244008)	1	• Spring pin		Obsolete part
17	(244699)	1	• Washer		Obsolete part
18	(862403)	12	• Stud		Obsolete part
19	(243743)	12	• Washer		Obsolete part
20	(1328134)	12	• Washer		Obsolete part
21	943927	12	• Hexagon nut		
22	960628	6	• Plug		(180707)
23	18836	6	• Gasket		
24	(243263)	1	• Sealing plug		Obsolete part
25	240017	1	• Gasket		
26	1699581	1	• Gasket		(1698192)
27	(240947)	1	• Cover		Obsolete part
28	(244732)	12	• Screw		Obsolete part
29	244406	1	• Bearing		
30	(849468)	2	• Screw		Obsolete part
31	(1698080)	1	• Camshaft		Obsolete part
32	35168	1	• Key		
33	240023	1	• Roller bearing		
34	864299	1	• Camshaft seal		
35	243299	1	• O-ring		
36	(240024)	X	• Shim		TH=0,10mm, Obsolete part
	(240025)	X	• Shim		TH=0,12mm, Obsolete part
	(240026)	X	• Shim		TH=0,14mm, Obsolete part
	(240027)	X	• Shim		TH=0,16mm, Obsolete part
	(240028)	X	• Shim		TH=0,18mm, Obsolete part
	(240029)	X	• Shim		TH=0,30mm, Obsolete part
	(240030)	X	• Shim		TH=0,50mm, Obsolete part
37	(240021)	1	• Bearing cover		Obsolete part
38	955806	1	• Hexagon nut		
39	941913	1	• Spring washer		
40	(1698078)	4	• Screw		Obsolete part
41	(244531)	1	• Control rod		Obsolete part
42	240023	1	• Roller bearing		
43	(240032)	1	• Ring		Obsolete part
44	(240033)	X	• Shim		TH=1,20mm, Obsolete part
	(240034)	X	• Shim		TH=1,50mm, Obsolete part
	(240035)	X	• Shim		TH=1,80mm, Obsolete part
	(240036)	X	• Shim		TH=2,00mm, Obsolete part
45	969011	1	• Gasket		

TMD122A

REF	PART NO.	QTY	DESCRIPTION	SEE SEC.	NOTES
46	35096	1	• Overflow valve		Replaced by 479775 for engines without fuel shut of valve or 3825154 for engines with fuel shut of valve.
	479775	1	• Overflow valve		For engines without shut-off valve.
	3825154	1	• Overflow valve		For engines with shut-off valve.
47	238614	1	• • Valve peg		Replaced by 35096
48	(863479)	1	• • Compression spring		Obsolete part
49	25540	1	• • Bushing		Replaced by 35096
50	244636	6	• Retainer		
51	240971	6	• Peg		
52	240972	X	• Washer		TH=0,20mm
	240973	X	• Washer		TH=0,50mm
53	240001	6	• O-ring		
54	240969	6	• Compression spring		
55	239993	6	• Sealing washer		
56	846188	6	• Delivery valve		
57		6	• Pump element		
58	240422	12	• O-ring		
59	(244733)	6	• Bushing		Obsolete part
60	(844990)	X	• Adjusting washer		TH=0,40mm, Obsolete part
	(847428)	X	• Adjusting plate		TH=0,45mm, Obsolete part
	(844991)	X	• Adjusting washer		TH=0,50mm, Obsolete part
	(847429)	X	• Adjusting plate		TH=0,60mm, Obsolete part
	(844992)	X	• Adjusting washer		TH=0,70mm, Obsolete part
	(244908)	X	• Shim		TH=0,75mm, Obsolete part
	(844993)	X	• Adjusting washer		TH=0,80mm, Obsolete part
	(847430)	X	• Adjusting plate		TH=0,85mm, Obsolete part
	(845238)	X	• Washer		TH=0,90mm, Obsolete part
	(244909)	X	• Shim		TH=0,95mm, Obsolete part
	(844994)	X	• Adjusting washer		TH=1,00mm, Obsolete part
	(244910)	X	• Shim		TH=1,05mm, Obsolete part
	(844995)	X	• Adjusting washer		TH=1,10mm, Obsolete part
	(244911)	X	• Shim		TH=1,15mm, Obsolete part
	(244633)	X	• Shim		TH=1,20mm, Obsolete part
	(844996)	X	• Adjusting washer		TH=1.25mm, Obsolete part
	(244634)	X	• Shim		TH=1,30mm, Obsolete part
	(847431)	X	• Adjusting plate		TH=1,35mm, Obsolete part
	(244635)	X	• Shim		TH=1,40mm, Obsolete part
	(847432)	X	• Adjusting plate		TH=1,45mm, Obsolete part
	(244381)	X	• Shim		TH=1,50mm, Obsolete part
	(244912)	X	• Shim		TH=1.55mm, Obsolete part
	(244382)	X	• Shim		TH=1,60mm, Obsolete part
	(244913)	X	• Shim		TH=1,65mm, Obsolete part
	(244383)	X	• Shim		TH=1,70mm, Obsolete part
	(244914)	X	• Shim		TH=1,75mm, Obsolete part
	(244384)	X	• Shim		TH=1,80mm, Obsolete part
	(244385)	X	• Shim		TH=1,90mm, Obsolete part
	(244386)	X	• Shim		TH=2.00mm, Obsolete part
	(847433)	X	• Adjusting plate		TH=2.10mm, Obsolete part
	(244915)	X	• Shim		TH=2.15mm, Obsolete part
	(244916)	X	• Shim		TH=2.20mm, Obsolete part
61	(846937)	6	• O-ring		Obsolete part
62	(241677)	6	• Washer		Obsolete part
63	(239991)	6	• Cover		Obsolete part
64	(1697953)	6	• Lock ring		Obsolete part
65	(240782)	6	• Control sleeve		Obsolete part
66	239984	6	• Spring disc		
67	244731	6	• Compression spring		
68	244685	6	• Spring disc		
69	(1698077)	6	• Tappet		Obsolete part
70	(238379)	6	• • Plate		Obsolete part
71	(240779)	6	• • Bearing bolt		Obsolete part
72	(1698299)	6	• • Roller		Obsolete part
75	845240	1	Repair kit		