

MD17D

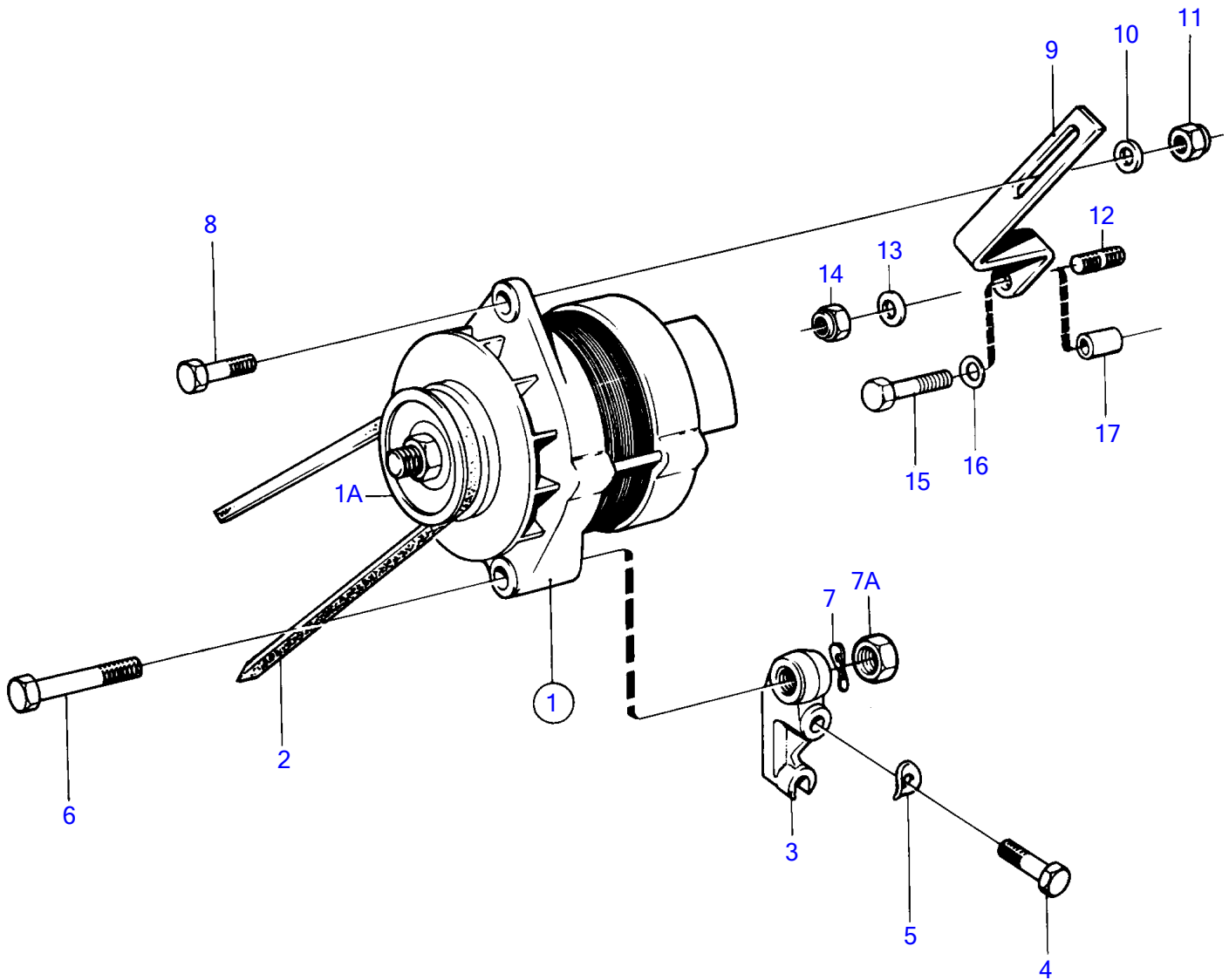

MD17D

REF	PART NO.	QTY	DESCRIPTION	NOTES
1	841762	1	Alternator	
1A	840380	1	Pulley	
2	958330	1	V-belt	MD17D/HD-HE SPEC 867684., L = 1500 MM
	958320	1	V-belt	L = 1250 MM
	958330	1	V-belt	SPEC 867684
3	840513	1	Bracket	MD17D/HD-HE SPEC 867684.
4	955321	1	Hexagon screw	MD17D/HD-HE SPEC 867684., L = 45 MM
5	942336	2	Spring washer	MD17D/HD-HE SPEC 867684.
6	955327	1	Hexagon screw	MO-18779, L = 75 MM
	955326	1	Hexagon screw	MO 18780-, L = 70 MM
	955329	1	Hexagon screw	MD17D/HD-HE SPEC 867684., L = 90 MM
7	942336	1	Spring washer	
7A	963107	1	Lock nut	MD17D/HD-HE SPEC 867684.
8	955298	1	Hexagon screw	MO-18779, L = 40 MM
	940132	1	Hexagon screw	MO 18780-, L = 35 MM
9	840501	1	Tensioner	OBSOLETE PART
10	191172	1	Washer	MO-18779
	960148	2	Washer	MO 18780-
11	955782	1	Hexagon nut	
15	955302	1	Hexagon screw	MO-18779, L = 60 MM
	955304	1	Hexagon screw	MO 18780-, L = 70 MM
16	941907	2	Spring washer	SPEC 867423, -426, -500., MO 17261-
17	820507	1	Spacer sleeve	OBSOLETE PART, L = 40 MM
	846425	1	Spacer sleeve	MD17D/HD-HE SPEC 867684.