

KAD42A, KAMD42A

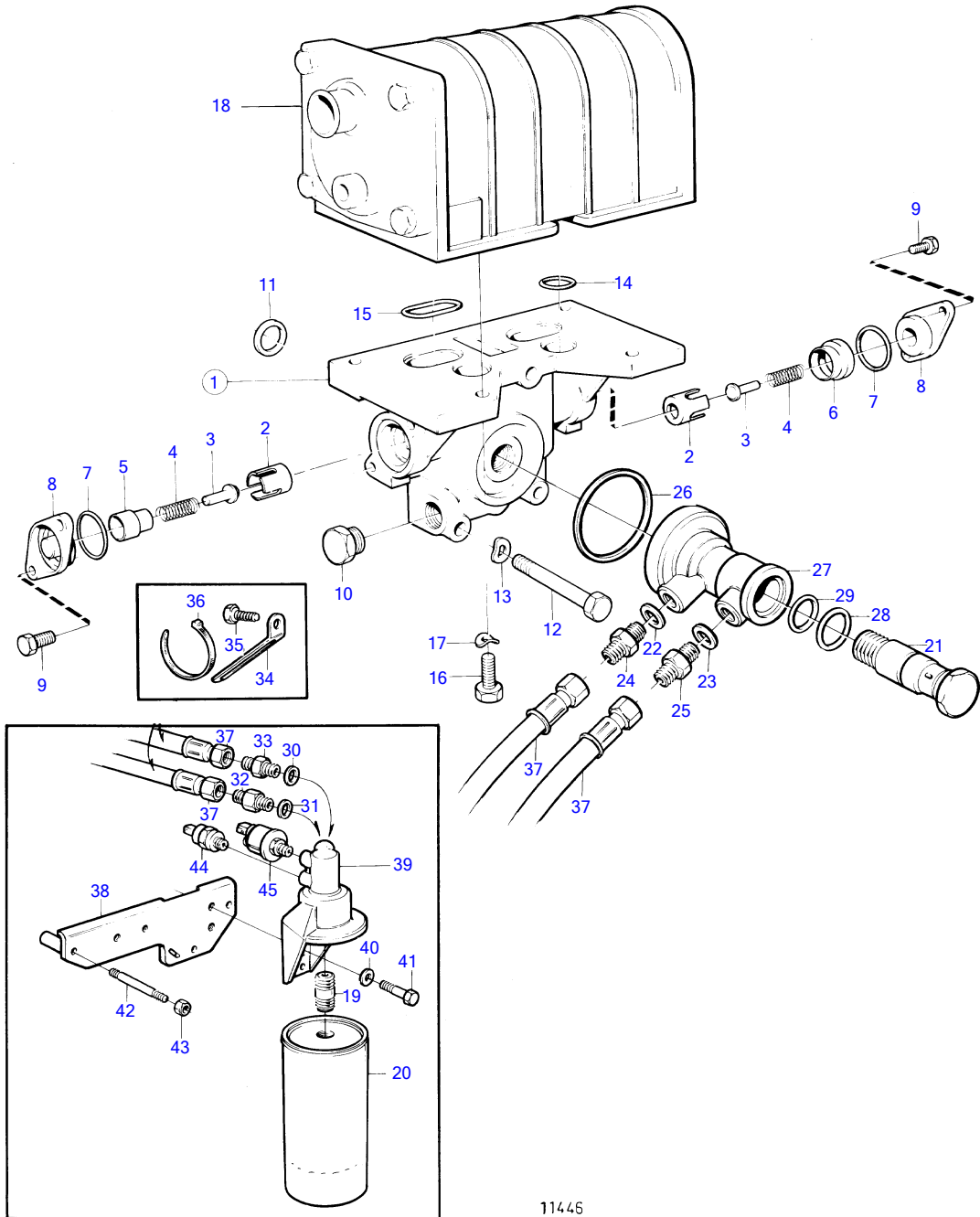

KAD42A, KAMD42A

REF	PART NO.	QTY	DESCRIPTION	SEE SEC.	NOTES
1		1	Oil filter housing		
2	1542265	2	• Valve seat		
3	471085	2	• Valve cone		
4	468087	2	• Spring		
5	3581951	1	• Sleeve		
6	3581950	1	• Sleeve		
7	949659	2	• O-ring		
8	1542267	2	• Cover		
9	946544	4	• Flange screw		
10	479977	1	• Plug		
11	469483	4	Sealing ring		
12	965182	3	Flange screw		
13	941907	3	Spring washer		Early type
14	469483	2	Sealing ring		
15	859086	2	Sealing ring		
16	946671	4	Flange screw		
17	941907	4	Spring washer		Early type
18		1	oil cooler		See group 2B
19	423067	1	Nipple		
20	4785974	1	Oil filter		
21	860482	1	Screw		
22	947627	1	Gasket		
23	947627	1	Gasket		
24	947554	1	Nipple		
25	3582505	1	Nipple		
26	967343	1	O-ring		
27	860483	1	Adapter		
28	949659	1	O-ring		
29	949721	1	O-ring		
30	947627	1	Gasket		
31	947627	1	Gasket		
32	3582505	1	Nipple		
33	947554	1	Nipple		
34	965558	1	Bracket		
35	946440	1	Flange screw		
36	948211	X	Cable tie		
37	860527	2	Oil hose		
38	(860529)	1	Bracket		Obsolete part
39	(860530)	1	Filter housing		Obsolete part
40	941907	2	Spring washer		
41	945444	2	Flange screw		
42	984130	2	Stud		
43	945408	2	Flange nut		
44	863169	1	Pressure monitor		0,7 bar
45	866835	1	Sensor		0-10 bar
			• Bulletin P-38-6-1	P-38-6-1-EN	Vibration Damping Kit