

D3-110I-D, D3-110I-E, D3-110I-F, D3-140I-E, D3-140I-F, D3-140A-D, D3-140A-E, D3-140A-F, D3-150I-D, D3-150I-E, D3-150I-F, D3-170I-D, D3-170I-E, D3-170I-F, D3-170A-D, D3-170A-E, D3-170A-F, D3-200I-D, D3-200I-E, D3-200I-F, D3-200A-D, D3-200A-E, D3-200A-F, D3-220I-D, D3-220I-E, D3-220I-F, D3-220A-D, D3-220A-E, D3-220A-F

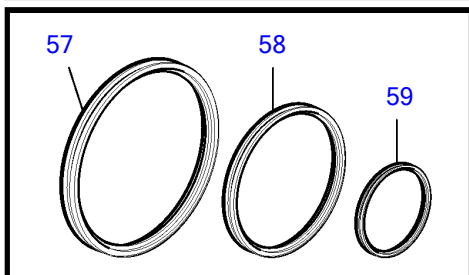
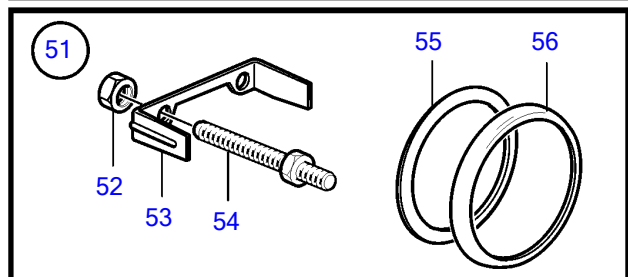
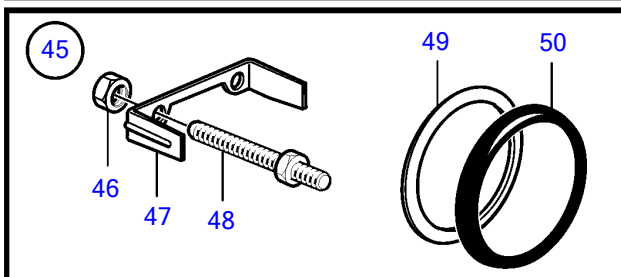
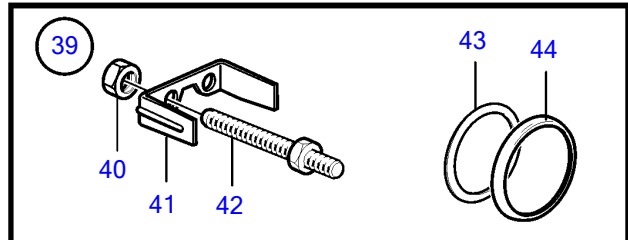
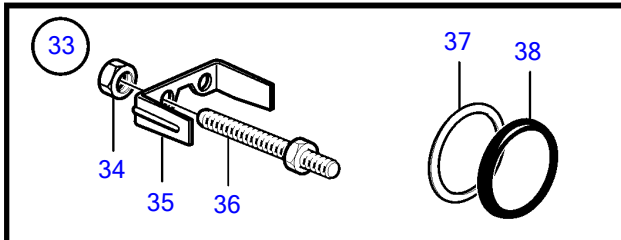
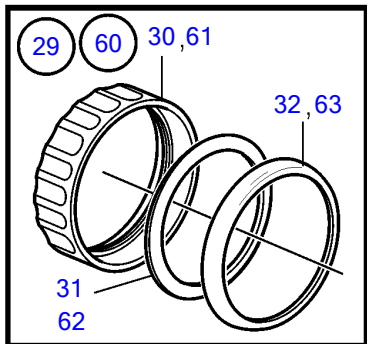
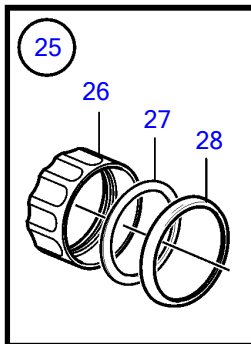
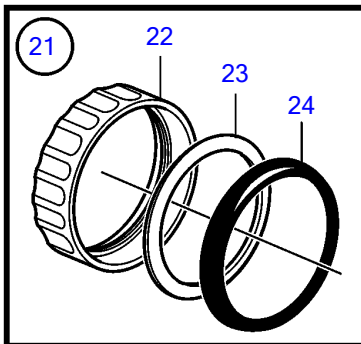
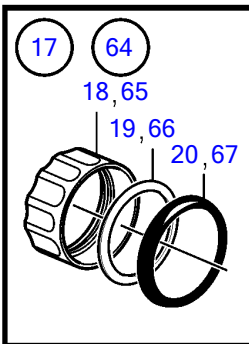
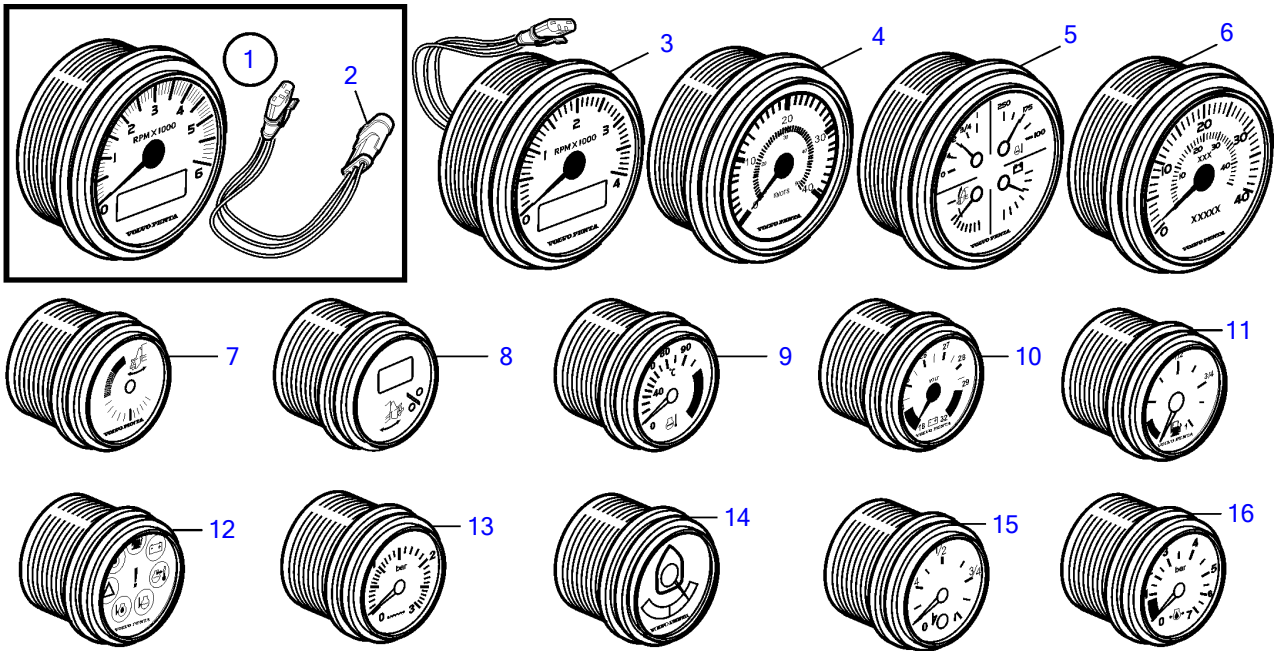

24903

D3-110I-D, D3-110I-E, D3-110I-F, D3-140I-E, D3-140I-F, D3-140A-D, D3-140A-E, D3-140A-F, D3-150I-D, D3-150I-E, D3-150I-F, D3-170I-D, D3-170I-E, D3-170I-F, D3-170A-D, D3-170A-E, D3-170A-F, D3-200I-D, D3-200I-E, D3-200I-F, D3-200A-D, D3-200A-E, D3-200A-F, D3-220I-D, D3-220I-E, D3-220I-F, D3-220A-D, D3-220A-E, D3-220A-F

REF	PART NO.	QTY	DESCRIPTION	SEE SEC.	NOTES
1	21509650	1	Tachometer kit		Black
	21509649	1	Tachometer kit		White
	21234541	1	Tachometer		Black, D=85mm, Only for main helm station, Cable not included
	21234537	1	Tachometer		White, D=85mm, Only for main helm station, Cable included
	21234544	1	Tachometer kit		White, D=110mm, Only for main helm station, Cable included
	21234545	1	Tachometer kit		Black, D=110mm, Only for main helm station, Cable not included
2	3884843	1	• Wiring harness		
3	21234543	1	Tachometer kit		Black, 4000rpm, D=110mm, Cable included
	21234542	1	Tachometer kit		White, 4000rpm, D=110mm, Cable included
4	21234531	1	Speedometer		Unit neutral, Black D=110mm, 0-40
	21234532	1	Speedometer		Unit neutral, White, D=110mm, 0-40
	21234533	1	Speedometer		Unit neutral, Black D=110mm, 0-60
	21234534	1	Speedometer		Unit neutral, White, D=110mm, 0-60
5	3847876	1	Instrument		Black, Four in one gauge (oil pressure, coolant temp, fuel level, volt meter), D=110mm
			• Bulletin P-36-9-3	P-36-9-3-EN	New products in the EVC family
5	3885214	1	Instrument		White, Four in one gauge (oil pressure, coolant temp, fuel level, volt meter)
			• Bulletin P-36-9-3	P-36-9-3-EN	New products in the EVC family
6	21234525	1	Speedometer		Black, 0-45 mph
	21234528	1	Speedometer		White, 0-45 mph
	21234529	1	Speedometer		Black, 0-70 mph
	21234530	1	Speedometer		White, 0-70 mph
7	3812881	1	Instrument		Black analog
	3812911	1	Instrument		White analog
8	881648	1	Trimmer		Black digital
	881654	1	Trimmer		White digital
9	874904	1	Thermometer, coolant water		Black 0-120°C
	874921	1	Thermometer, coolant water		White 0-120°C
	874918	1	Thermometer, coolant water		Black 40-250 °F
	874931	1	Thermometer, coolant water		White 40-250 °F
10	881649	1	Voltmeter		Black, 12V
	881658	1	Voltmeter		White, 12V
11	874914	1	Fuel gauge		Black D=52mm
	874926	1	Fuel gauge		White D=52mm
12	874915	1	Instrument, alarm		Black D=52mm
	874927	1	Instrument, alarm		White D=52mm
13	874910	1	Turbo pressure gauge		Black 0-3 bar
	874924	1	Turbo pressure gauge		White 0-3 bar
	874920	1	Turbo pressure gauge		Black 0-45 psi
	874933	1	Turbo pressure gauge		White 0-45 psi
14	3812914	1	Rudder indicator		Black
	3812917	1	Rudder indicator		White
15	3809992	1	Water level gauge		Black, Water level gauge
	3809993	1	Water level gauge		White, Water level gauge
16	874908	1	Oil pressure gauge, engine		Black 0-7 bar
	874923	1	Oil pressure gauge, engine		White 0-7 bar
	874919	1	Oil pressure gauge, engine		Black 0-100 psi
	874932	1	Oil pressure gauge, engine		White 0-100 psi
17	874709	1	Mounting kit		
18	874450	1	• Attaching ring		
19	874707	1	• Gasket		
20	874448	1	• Ring		
21	874708	1	Mounting kit		
22	874449	1	• Attaching ring		
23	874706	1	• Gasket		
24	874447	1	• Ring		
25	874733	1	Mounting kit		
26	874450	1	• Attaching ring		
27	874707	1	• Gasket		
28	874731	1	• Ring		
29	874732	1	Mounting kit		
30	874449	1	• Attaching ring		

D3-110I-D, D3-110I-E, D3-110I-F, D3-140I-E, D3-140I-F, D3-140A-D, D3-140A-E, D3-140A-F, D3-150I-D, D3-150I-E, D3-150I-F, D3-170I-D, D3-170I-E, D3-170I-F, D3-170A-D, D3-170A-E, D3-170A-F, D3-200I-D, D3-200I-E, D3-200I-F, D3-200A-D, D3-200A-E, D3-200A-F, D3-220I-D, D3-220I-E, D3-220I-F, D3-220A-D, D3-220A-E, D3-220A-F

REF	PART NO.	QTY	DESCRIPTION	SEE SEC.	NOTES
31	874706	1	• Gasket		
32	874730	1	• Ring		
33	881611	1	Brace kit		Black D=52mm
34	881610	2	• Nut		
35	881607	1	• Brace		
36	881609	2	• Stud		
37	874707	1	• Gasket		
38	874448	1	• Ring		
39	881613	1	Brace kit		Chrome D=52mm
40	881610	2	• Nut		
41	881607	1	• Brace		
42	881610	2	• Nut		
43	874707	1	• Gasket		
44	874731	1	• Ring		
45	881612	1	Brace kit		Black D=85mm
46	881610	2	• Nut		
47	881608	1	• Brace		
48	881609	2	• Stud		
49	874706	1	• Gasket		
50	874447	1	• Ring		
51	881614	1	Brace kit		Chrome D=85mm
52	881610	2	• Nut		
53	881608	1	• Brace		
54	881609	2	• Stud		
55	874706	1	• Gasket		
56	874730	1	• Ring		
57	3886791	1	X-ring		For flush mounting., D=110mm
			• Bulletin P-36-9-3	P-36-9-3-EN	New products in the EVC family
58	874843	1	X-ring		For flush mounting., D=85mm
59	874844	1	X-ring		For flush mounting., D=52mm
60	3885216	1	Mounting kit		Chrome D=110mm
			• Bulletin P-36-9-3	P-36-9-3-EN	New products in the EVC family
61	(3884098)	1	• Attaching ring		Obsolete part
62	3884103	1	• Gasket		
63	3884096	1	• Ring		
64	3847888	1	Mounting kit		Black D=110mm
			• Bulletin P-36-9-3	P-36-9-3-EN	New products in the EVC family
65	3847887	1	• Ring		
66	3884103	1	• Gasket		
67	(3884098)	1	• Attaching ring		Obsolete part