

D16C-A MH, D16C-A MG

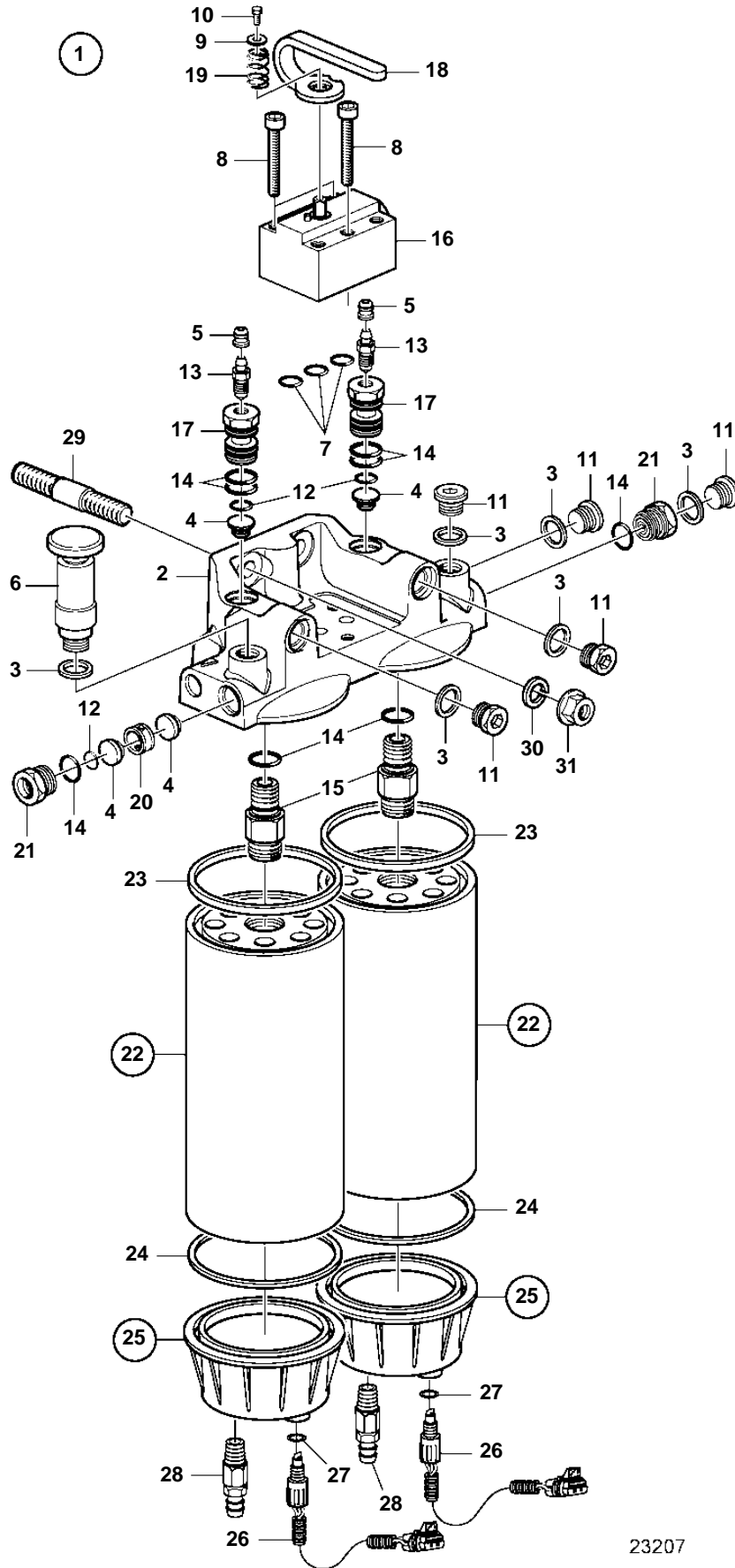

23207

D16C-A MH, D16C-A MG

REF	PART NO.	QTY	DESCRIPTION
1		1	Filter housing
2	3808691	1	· Filter housing
3	11996	5	· Gasket
4	244834	4	· Valve
5	20547976	2	· Protecting cover
6	3837393	1	· Hand pump
7	944364	3	· O-ring
8	959227	3	· Screw
9	3839116	1	· Cap washer
10	963537	1	· Screw
11	966143	5	· Plug
12	976971	3	· O-ring
13	20548012	2	· Tap
14	1526474	8	· O-ring
15	3831210	2	· Nipple
16	3835369	1	· Valve body
17	3835370	2	· Nipple
18	3842870	1	· Handle
19	3842868	1	· Compression spring
20	3964717	1	· Spacer sleeve
21	8148328	2	· Nipple
22	3817517	2	Fuel filter
23		2	· Gasket
24		2	· Gasket
25	3885578	2	Bowl
26	3885070	2	· Sender
27		2	· · Gasket
28	949918	2	· Drain cock
29	977297	2	Stud
30	941908	2	Spring washer
31	971095	2	Nut