

D13B-A MP

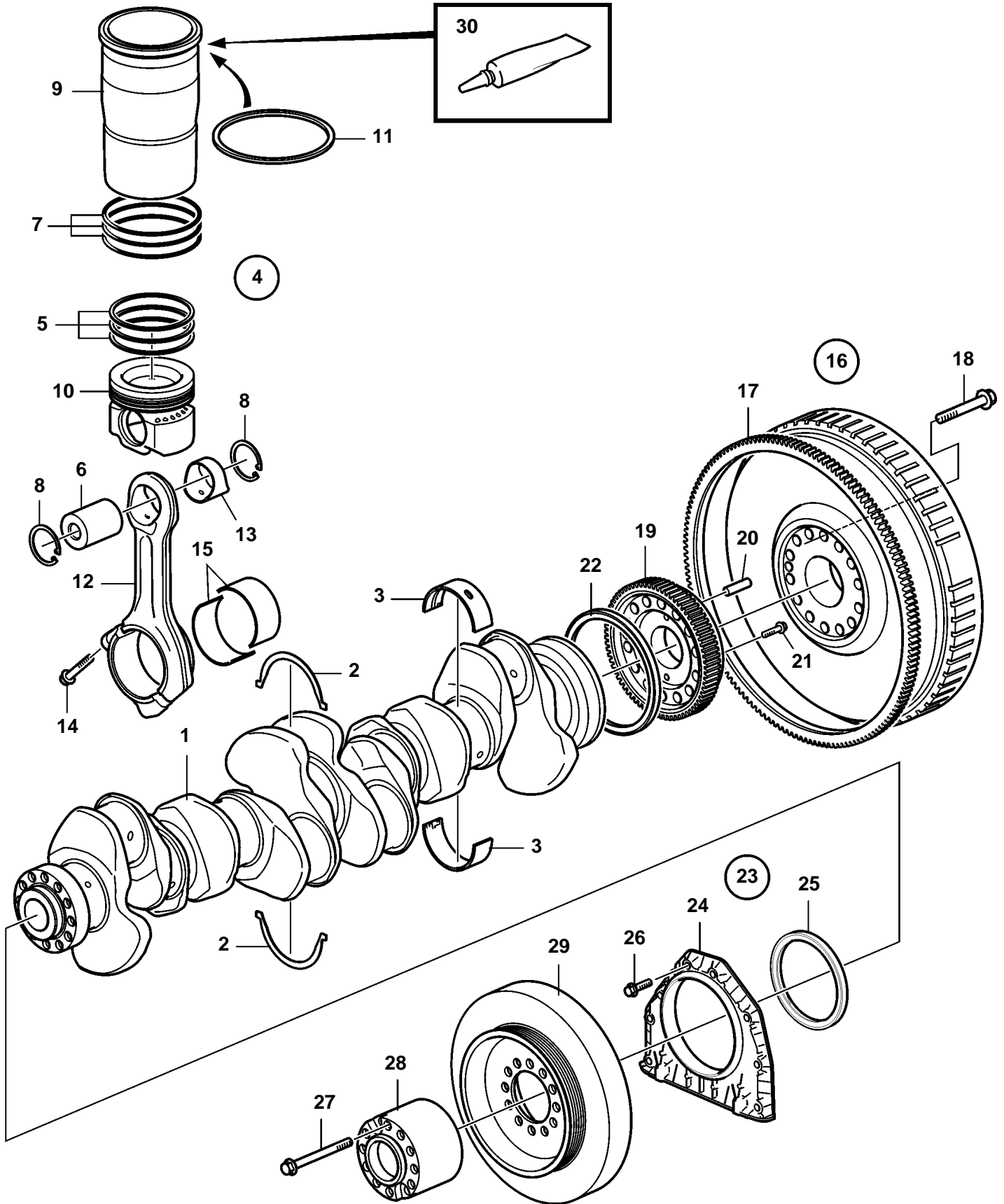

D13B-A MP

REF	PART NO.	QTY	DESCRIPTION	NOTES
1		1	Crankshaft	
2	3093651	1	Thrust washer	Std
3	20530916	7	Main bearing	Std
4	21397404	6	Cylinder liner kit	
5	21253763	1	· Piston ring kit	
6		1	· Piston pin	
7	270950	1	· Sealing kit	
8	914531	2	· Snap ring	
9		1	· Cylinder liner	
10		1	· Piston	
11	1677591	X	Shim	TH = 0,2mm
	1677592	X	Shim	TH = 0,3mm
	1677593	X	Shim	TH=0,5mm
12		6	Connecting rod	
13	20730398	1	· Bushing	
14	20486228	4	· Screw	
15	20580558	6	Bearing	Std
	20711963	6	Bearing	O.S=0,25mm
	20711964	6	Bearing	O.S=0,50mm
	20711966	6	Bearing	O.S=1,00mm
16	3886315	1	Flywheel	
17	20711957	1	· Ring gear	(8193939)
18	21344746	14	Screw	
19	20743004	1	Gear	
20	950658	1	· Pin	
21	947760	2	Flange screw	
22	85108352	1	Sealing ring	
23	20777233	1	Cover	(20513482)
24		1	· Timing gear cover	
25	85108423	1	· Crankshaft seal	(1549398)
26	946671	8	Flange screw	
27	965195	12	Flange screw	
28	3595298	1	Adapter	
29	3594670	1	Vibration damper	
30	1161231	X	Sealant	304ml
	1161277	X	Sealant	20g