

D12D-A MP, D12D-B MH

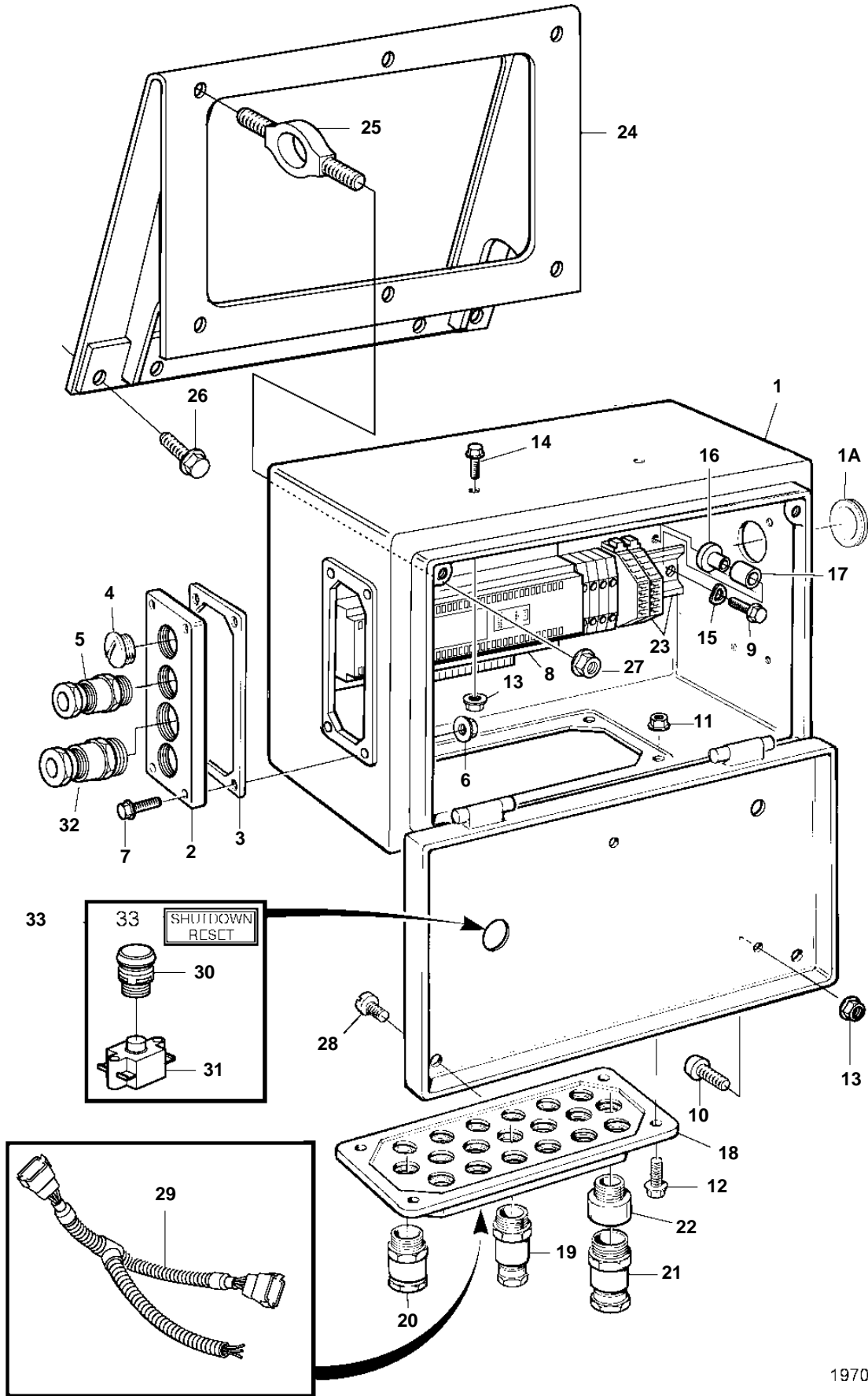

19704

D12D-A MP, D12D-B MH

REF	PART NO.	QTY	DESCRIPTION	SEE SEC.	NOTES
1	3587009	1	Electrical distribut		
1A	941269	1	· Cable grommet		
2	843094	1	Flange		
3	843578	1	Gasket		
4	843903	3	Plug		
5	881193	1	Cable union		
6	963105	8	Nut		M6
7	946544	4	Flange screw		M6x16
8	3819845	1	Electronic unit		Shutdown unit
			Bulletin P-28-4-4	P-28-4-4-EN	Software Handling Procedures
9		2			M5x25
10	965199	4	Screw		M6x14
11	963104	4	Nut		M5
12	956075	4	Screw		M5x10
13	965483	10	Nut		
14	965199	6	Screw		
15	960138	2	Washer		
16	824830	2	Spacer sleeve		
17	403894	2	Spacer sleeve		
18		1	Flange		
19	881190	1	Cable union		4,5-7,5mm, PR 15,2
	881191	X	Cable union		7,5-10,5mm, PR 18,6
20	844576	X	Cable union		9,5-12,0mm, PR 18,6
21	881192	X	Cable union		12,5-15,0mm, PR 22,5
22	872939	1	Adapter, electr box-altern-starter		D=18,6-22,5mm
	862885	1	Reducer sleeve		FOR 881190. D=15,2-18,6mm
23	888003	1	Terminal block, converter		
24	3832497	1	Bracket		
25	3839156	4	Rubber cushion		
26	946441	2	Screw		
27	945407	8	Flange nut		
28	946471	1	Screw		
29	881630	1	Cable kit		
30	3817578	1	Switch		(863104)
31	873791	1	Switch		
32	822327	1	Cable union		8,5-11,5mm, PR 22,5
33		1	Decal		