

D11A-A, D11A-B, D11A-C, D11A-D

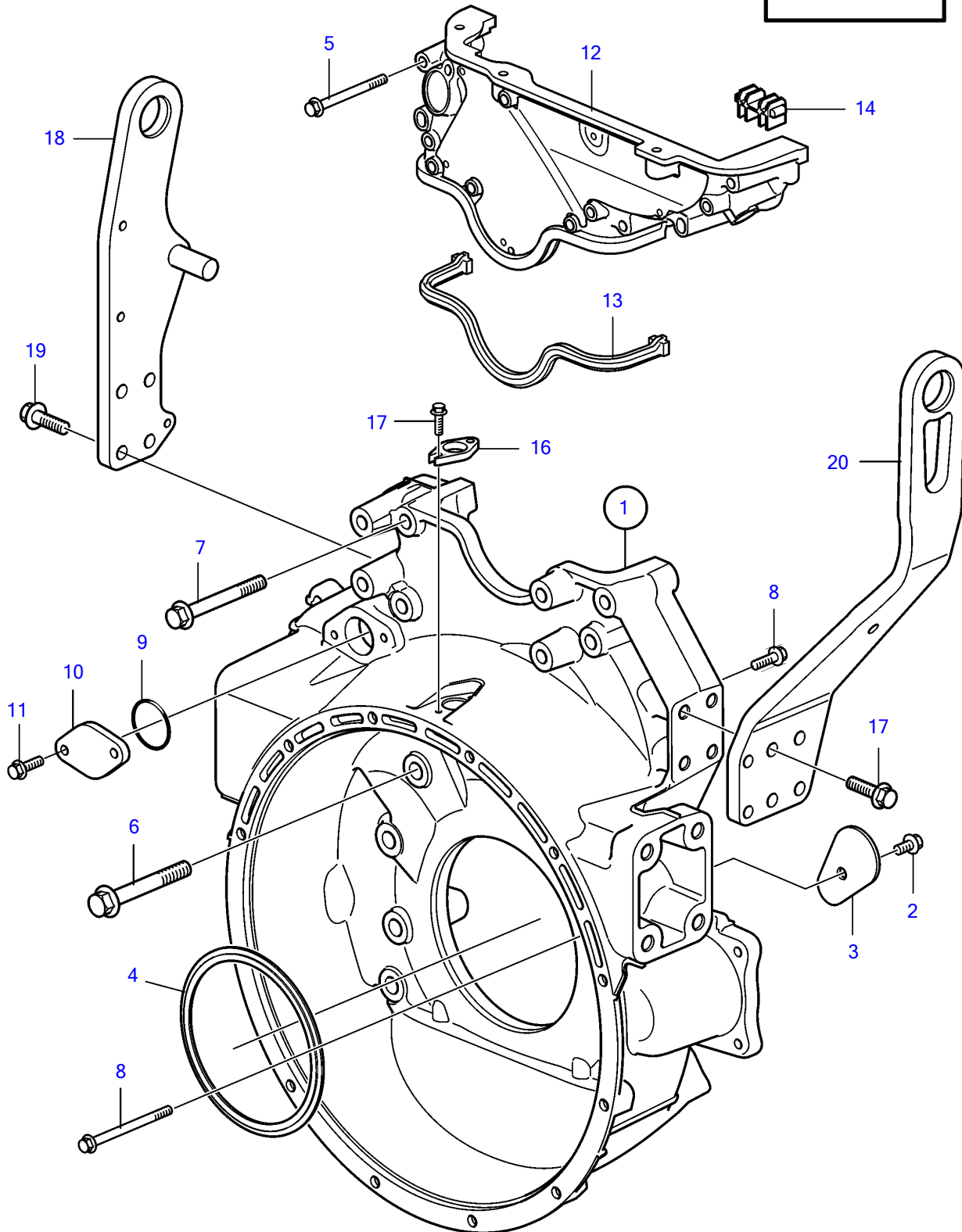
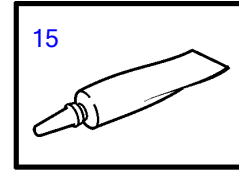

## D11A-A, D11A-B, D11A-C, D11A-D

REF	PART NO.	QTY	DESCRIPTION	NOTES
1	21393440	1	Flywheel housing	
2	946440	1	• Flange screw	
3	3849378	1	• Cover plate	
4	8148259	1	Crankshaft seal	
5	969189	5	Flange screw	L=85mm
6	966367	6	Flange screw	L=100mm
	966369	1	Flange screw	L=120mm
7	965197	4	Flange screw	L=100mm
8	946173	6	Flange screw	L=20mm
	975199	2	Flange screw	L=35mm
	975192	1	Flange screw	L=100mm
9	948610	1	O-ring	
10	3884277	1	Cover	
11	945444	2	Flange screw	
12	20764595	1	Timing gear cover	
13	20817742	1	Gasket	
14	20572441	2	Gasket	
15	1161277	X	Sealant	20g
16	3885657	1	Shim	
17	946934	2	Flange screw	
18	(3589187)	1	Lifting eye	Obsolete part, P
19	965225	8	Flange screw	
20	3586761	1	Lifting eye	S.B