

VOLVO PENTA AQUAMATIC

D3-160/SX

120 kW (163 hp) crankshaft power acc. to ISO 8665

Power for fun

Volvo Penta's new 5-cylinder D3-160 is developed from the latest design in modern diesel technology. The engine is extremely lightweight and compact. With features like common rail fuel injection system, double overhead camshafts, 4 valves per cylinder, variable geometry turbocharger, aftercooler and the EVC (Electronic Vessel Control) a world-class diesel performance, combined with low emissions, is achieved.

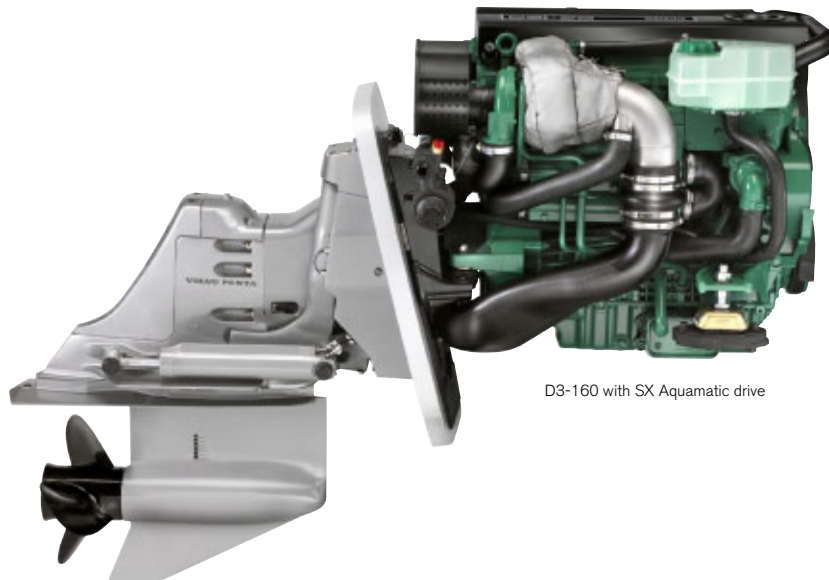

D3-160 with SX Aquamatic drive

World-class performance

The common rail fuel injection system, controlled by EVC, in combination with the large swept volume and Variable Geometry Turbine (VGT), ensures outstanding torque during acceleration, with virtually no sign of smoke. This matched with the engine's low weight creates a real performer for boating fun.

Low weight

The engine has an extremely low weight for its power output. This thanks to the all aluminum base engine, and a highly efficient marinization. This contributes to a power/weight ratio comparable with a gasoline engine.

The engine is fitted with freshwater cooling as standard for long service life.

Compact and robust

The engine is ultra-compact for its large swept volume. With cast-in grey iron cylinder liners, a 2-mass flywheel, integrated freshwater pump, a compact marinization, and a fully symmetric engine, the package simply gets that compact.

The rigid aluminum cylinder block and bed plate in wedge structure, and exactly controlled high-pressure fuel injection gives excellent onboard comfort with low noise and vibration levels.

EVC/MC - Plug and go

EVC Electronic Vessel Control is the latest development in instrumentation for marine engines with mechanical shift and throttle.

With EVC/MC you can tailor the instrumentation to fit the boat, from a single tachometer with an LCD window, where you can read all engine/boat data, to a dashboard full with standard gauges or any combination in between. EVC/MC offers an optional multi-sensor to read speed, depth and surface water temp. The system is built on the latest automotive technology with waterproof connectors, so it's just plug and go.

EVC makes boating easier offering adjustable trim limits. EVC works closely together with the engine management system offering you constant power output regardless of temperature (5–55°C/41–131°F) and quality of the fuel.

SX drive

The SX single propeller drive is a well-proven design with exhaust through the drive and propeller hub for quiet and efficient operation. Cone clutch for easy and smooth shifting. Pattern-matched spiral bevel gears for optimum strength and minimum gear whine. Break-away shaft coupling to prevent costly drive-train repairs.

The package is equipped with Power steering as standard.

Meeting new emission standards

The common rail injection system in combination with electronics and an advanced combustion system are setting new standards in minimizing noxious emissions and particles. The engine will meet future comprehensive emission requirements to be introduced in Europe in 2006 and in the US in 2007.

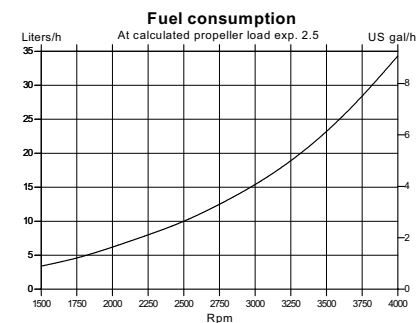
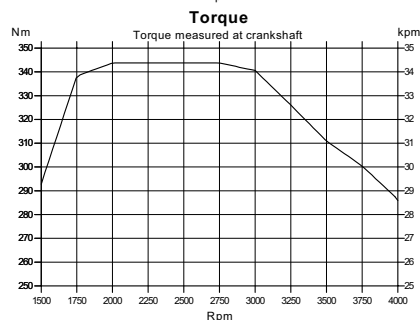
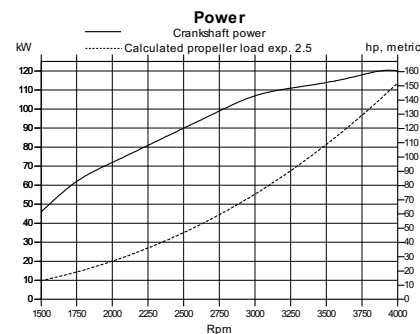

**VOLVO
PENTA**

D3-160/SX

Technical description:

Engine block and head

- Cylinder block and cylinder head made of aluminum
- Cylinder block with integrated bed plate
- 4-valve technology with hydraulic lash adjusters
- Double overhead camshafts
- Oil-cooled pistons with two compression rings and one oil scraper ring
- Cast-in grey iron cylinder liners
- Replaceable valve seats
- Six-bearing crankshaft
- Front-end transmission

Engine mounting

- Flexible engine mounting

Lubrication system

- Easily replaceable (insert) full-flow oil filter
- Plate oil cooler

Fuel system

- Common rail fuel injection system
- Control unit for processing the injection
- Fine filter with water separator

Air inlet and exhaust system

- Air filter with replaceable insert
- Closed crankcase ventilation with oil separator of cyclone type

- Exhaust elbow of stainless steel
- Turbocharger with variable geometry

Cooling system

- Thermostatically regulated freshwater cooling
- Tubular heat exchanger with separate large volume expansion tank
- Coolant system prepared for hot water outlet
- Easily accessible impeller pump
- Integrated seawater coolant pick-up through drive

Electrical system

- 12V one-pole electrical system
- 140A alternator, and integrated temperature compensated charging regulator
- Auxiliary stop button

Instruments/control

- Mechanical shift and throttle
- Basic instrumentation including key switch and interlocked alarm
- Digital Power Trim instrument with analog or digital reading
- Plug-in connections

Drive

- Single propeller drive which can be run with both right- and left-hand propellers

- Cone clutch
- Pattern-matched spiral bevel gears
- Complete connection for exhaust outlet through the drive and hub
- Overload protection sleeve (break-away coupling)
- Max tilt angle 55°
- The drive can be turned 28° in each direction
- Built-in kick-up function to reduce possible damage, in the event the drive strikes an underwater object
- Active corrosion protection as accessory

Power Trim

- Electrically operated hydraulic system for trimming the drive for best driving comfort
- An analog instrument for indication of trim angle

Accessories

An extensive range of accessories are available. For detailed information, please see Accessory catalogs.

Contact your local Volvo Penta dealer for further information.

Not all models, standard equipment and accessories are available in all countries. All specifications are subject to change without notice.

The engine illustrated may not be entirely identical to production standard engines.

Technical Data

Engine designation	D3-160 A
Crankshaft power, kW (hp)	120 (163)
Propeller shaft power, kW (hp)	115 (157)
Engine speed, rpm	4000
Displacement, l (in ³)	2.4 (146)
Number of cylinders	5
Bore/stroke, mm (in.)	81/93.2 (3.19/3.66)
Compression ratio	18 :1
Volvo Penta Aquamatic drive	SX
Ratio	1.66:1
Dry weight with SX, excl. prop., kg (lb)	325 (717)

Duty rating: R5

Technical data according to ISO 8665. Fuel with a lower calorific value of 42,700 kJ/kg and density of 840 g/liter at 15°C (60°F).

Merchant fuel may differ from this specification which will influence engine power output and fuel consumption.

The engine will meet future comprehensive emission requirements to be introduced in Europe in 2006 and in the US in 2007.

Dimensions D3-160/SX

Not for installation

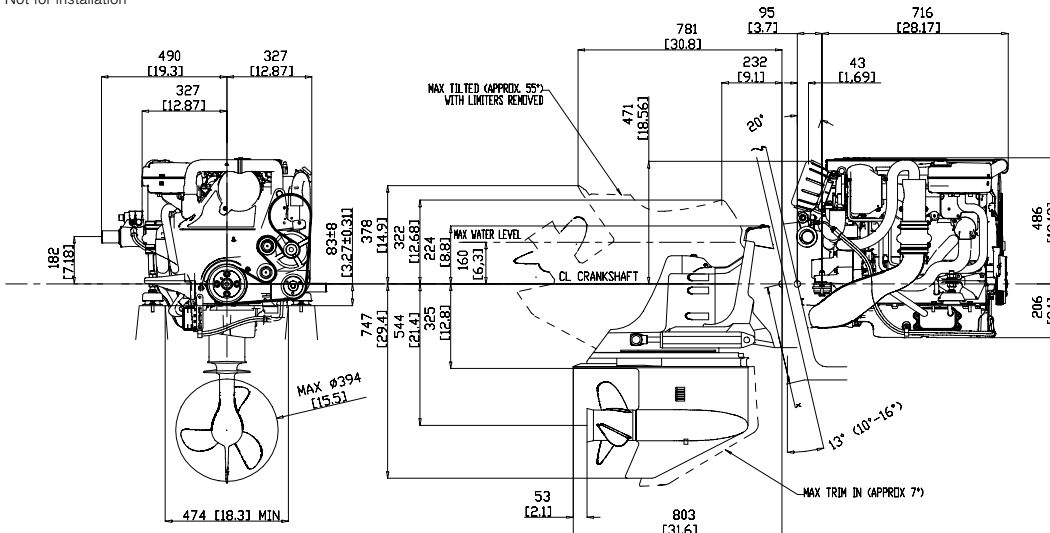

VOLVO PENTA

AB Volvo Penta
SE-405 08 Göteborg, Sweden
www.volvopenta.com