

XHP-B, XHP-BLT, XXP-A, XXP-ALT

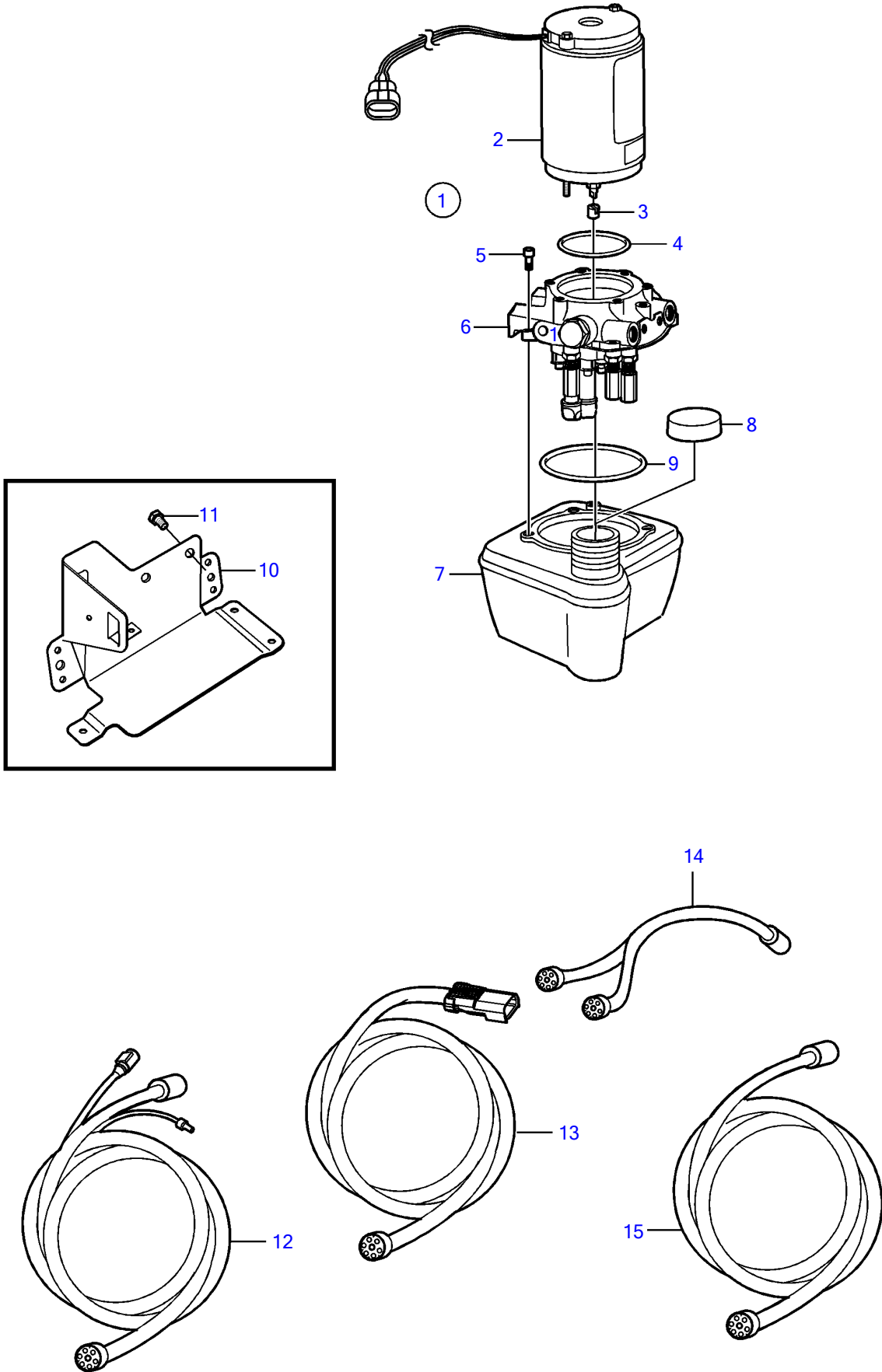

XHP-B, XHP-BLT, XXP-A, XXP-ALT

REF	PART NO.	QTY	DESCRIPTION	NOTES
1	3819847	1	Trimmer, trim	
2	3861576	1	• Electrical motor	
3	3861577	1	• Connector	
4	3861578	1	• O-ring	
5	3861574	4	• Screw	
6		1	• Valve body	Not serviced
7	3861570	1	• Reservoir	
8	3861572	1	• • Cardboard tube	
9	3861573	1	• • O-ring	
10	3858083	1	• Bracket	
11	971017	2	• Hexagon screw	
12	3855709	X	Wiring harness, trim	5m
	3855708	X	Wiring harness, trim	7m
13	3887226	X	Wiring harness, trim	6m
14	3855712	X	Wiring harness, y	Dual station
15	3855710	X	Wiring harness, extension	3m
	3855711	X	Wiring harness, extension	5m