

1

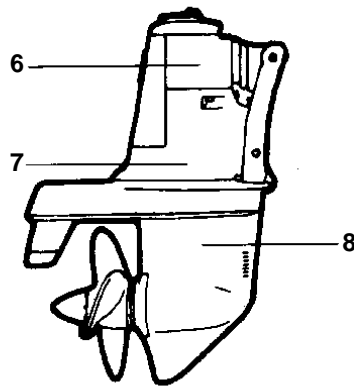

5

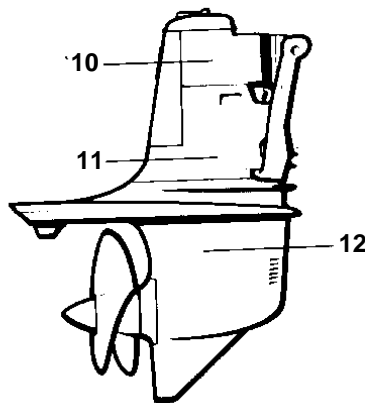

9

3440

REF	PART NO.	QTY	DESCRIPTION	SEE SEC.	NOTES
9		1			NOT INCLUDED IN 839359, ONLY FOR FOLDING PROPELLER., INCLUDED IN AQ DRIVE UNIT 850354, 850356., RATIO 1,61:1
	839401	1	Protecting cap		REPLACED BY 839390., RATIO 1,61:1
	839402	1	Protecting cap		NOT INCLUDED IN 839359, ONLY FOR FOLDING PROPELLER., 804227 AND 804218 REPLACED BY 826341., RATIO 2,15:1
	850354	1	Drive		MD5B SPEC 867452., REPLACED BY GEAR SET 3576122., INCLUDED IN AQ DRIVE UNIT 850354, 850356., RATIO 1,61:1
	850356	1	Drive		MD5B SPEC 867452., REPLACED BY GEAR SET 3576122., 804227 AND 804218 REPLACED BY 826341., RATIO 2,15:1
	851317	1	Drive		INCLUDED IN AQ DRIVE UNIT 850831., TO BE INSTALLED ON BOATS WITH HEAVY INCLINED STERNS., RATIO 1,61:1
	851318	1	Drive		INCLUDED IN AQ DRIVE UNIT 850831., RATIO 2,15:1
		1			REPLACED BY 839391., RATIO 1,61:1
		1			REPLACED BY 1EA 875425 1EA 839253 1EA 914538., RATIO 1,89:1
10		1			INCLUDED IN FOLDING PROPELLER., REPLACED BY 1EA 814598 1EA 814601 1EA 814603.
	850460	1	· · Upper gear		EARLY TYPE OF SPLINE SLEEVE IS REPLACED BY SHAFT 852527 + SPLINE SLEEVE 852534., REPLACED BY 1EA 814598 1EA 814601 1EA 814603.
	851340	1	· · · Upper gear, UPPER GEAR UNIT		REPLACED BY 850788.
11		1	· · · · INTERM HOUSING 280	12918	
		1	· · · · INTERM HOUSING 280T	12919	
12		1	· · · · LOWER GEAR UNIT	12920	
		1	GASKET KIT		SEE GROUP 10