

TAMD162A, TAMD162B, TAMD162C, TAMD162C-B

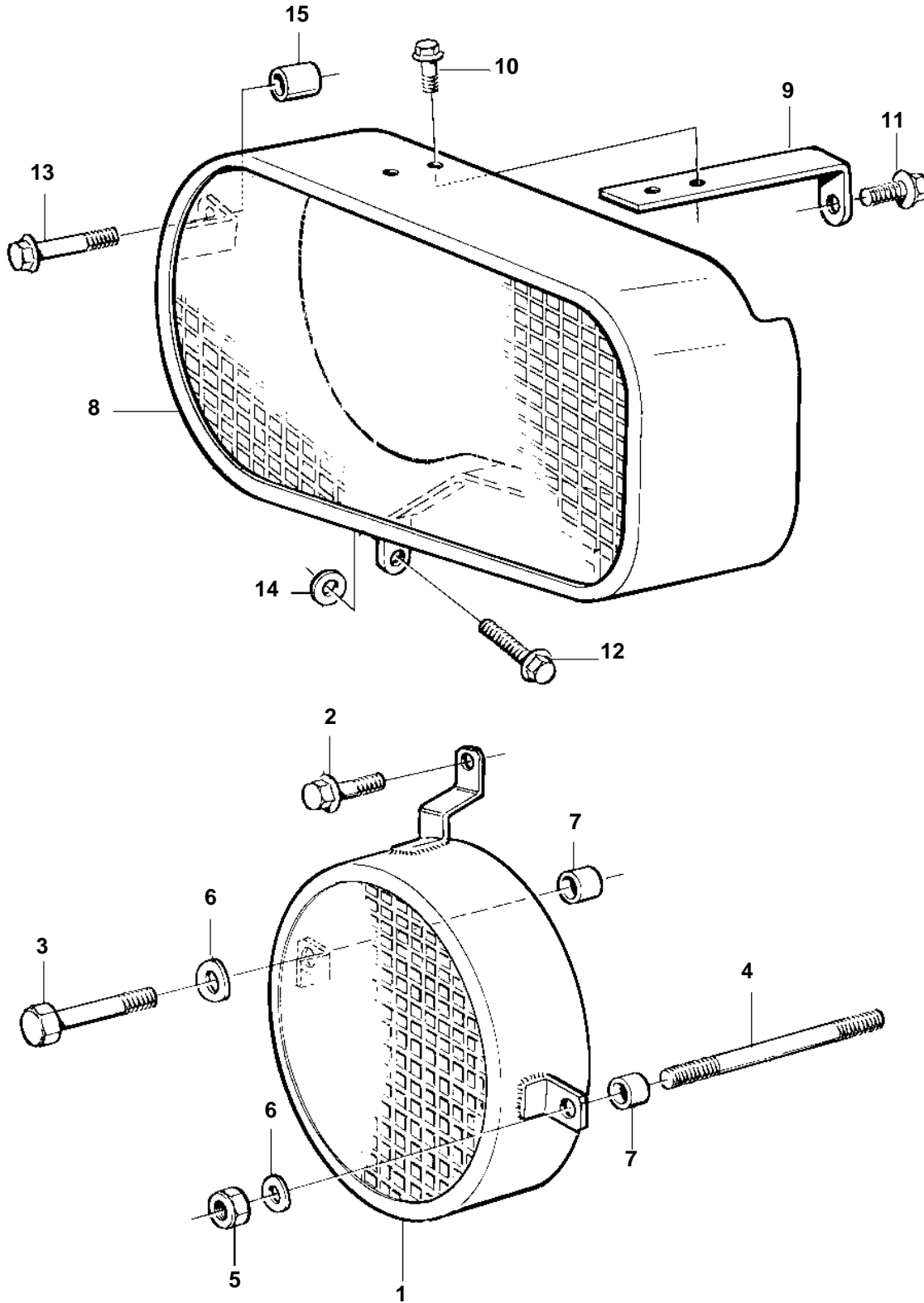

TAMD162A, TAMD162B, TAMD162C, TAMD162C-B

REF	PART NO.	QTY	DESCRIPTION		NOTES
1	3825916	1	Protecting casing, vibration damper		
2	965192	1	Flange screw		
3	971006	1	Screw		
4	973202	1	Stud		
5	961994	1	Nut		
6	941911	2	Spring washer		
7	1678297	8	Spacer sleeve		L=14,2mm
	823196	2	Spacer sleeve		L=11mm
8	866804	1	Protecting casing, alternator	SO	
9	866805	1	Bracket	SO	
10	947107	2	Flange screw		
11	946441	1	Screw		
12	946817	1	Screw		
13	965226	1	Flange screw		
14	955897	1	Washer		
15	830672	1	Spacer sleeve		Should not be used when clutch casing for power take off is installed.