

THAMD70B,AQD70BL

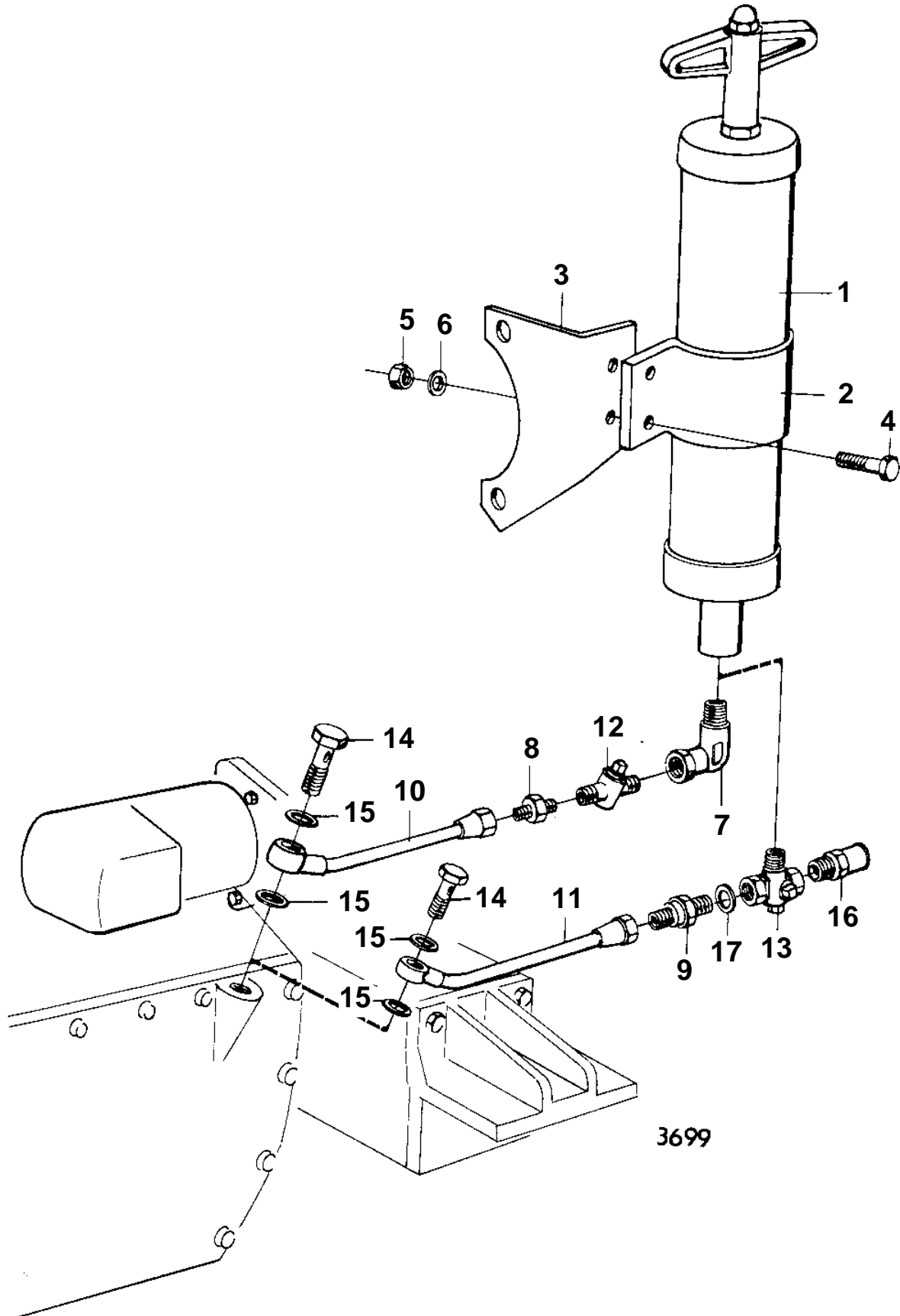

THAMD70B,AQD70BL

REF	PART NO.	QTY	DESCRIPTION	NOTES
1	880199	1	Oil bilge pump	
2	776990	1	Clamp	
3	836736	1		MO-XXXX/12779
	842225	1	Bracket	MOXXXX/12780-
4	940115	2	Screw	MO-XXXX/12779
	940114	2	Screw	MOXXXX/12780
5	955827	2	Nut	MO-XXXX/12779
6	942336	2	Spring washer	MO-XXXX/12779
7	803809	1	Nipple	MO-XXXX/11043
8	954337	1	Nipple	MO-XXXX/11043
9	828005	1	Nipple	MOXXXX/11044-
10		1	PIPE	MO-XXXX/11043. REPLACED BY 1EA 837384, 1EA 837383, 1EA 828005, 1EA 907133, 1EA 803648.
11	837384	1	Tube	MOXXX/11044-XXX/12779
	842227	1	Oil scavenging pipe	MOXXXX/12780-
12	803808	1	Tap	MO-XXXX/11043
13	837383	1	Tap	MOXXXX/11044-
14	26013	1	Hollow screw	
15	957181	2	Gasket	
16	803648	1	Hose attachment	MOXXXX/11044-
17	907133	1	Washer	MOXXXX/11044-