

MD2010B, MD2020B

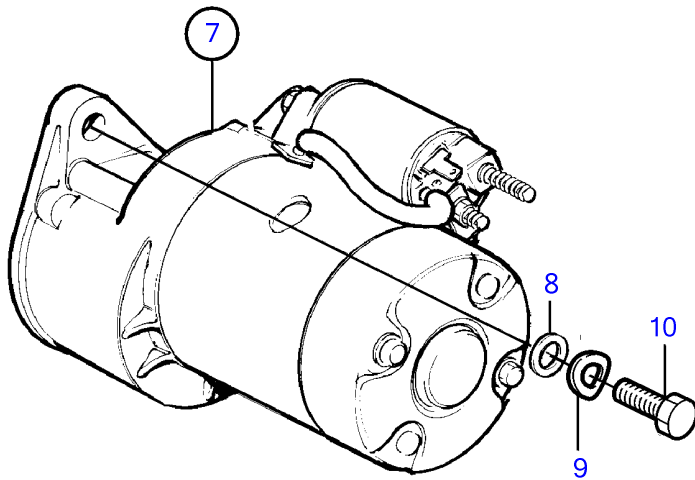
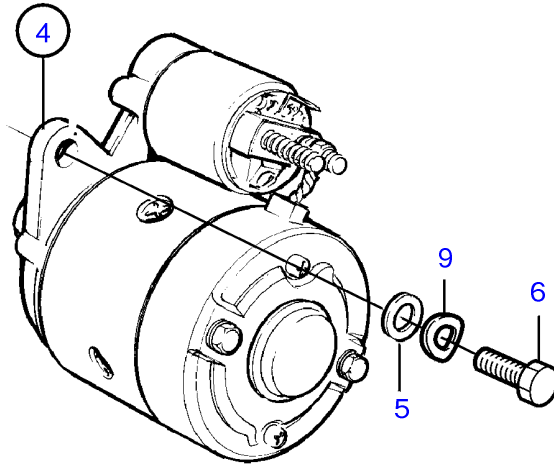
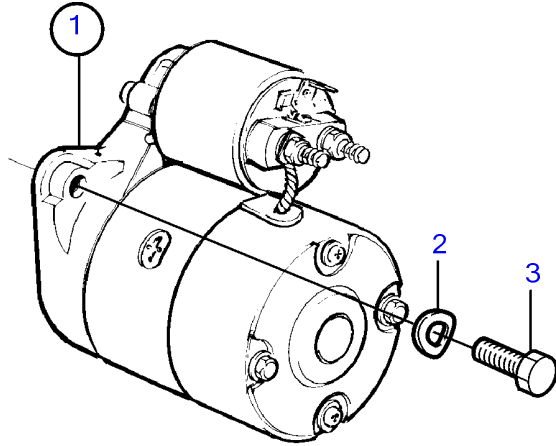

MD2010B, MD2020B

REF	PART NO.	QTY	DESCRIPTION	SEE SEC.	NOTES
1	861845	1	Starter motor		Replaced by 3803904
			.	199	
	3803904	1	Starter motor, exch		
			.	21449	
2	861847	2	Washer		
3	861846	2	Screw		
4			.	256	
			.	256	
7			.	257	
			parts not sold separately		