

TAMD42WJ-A

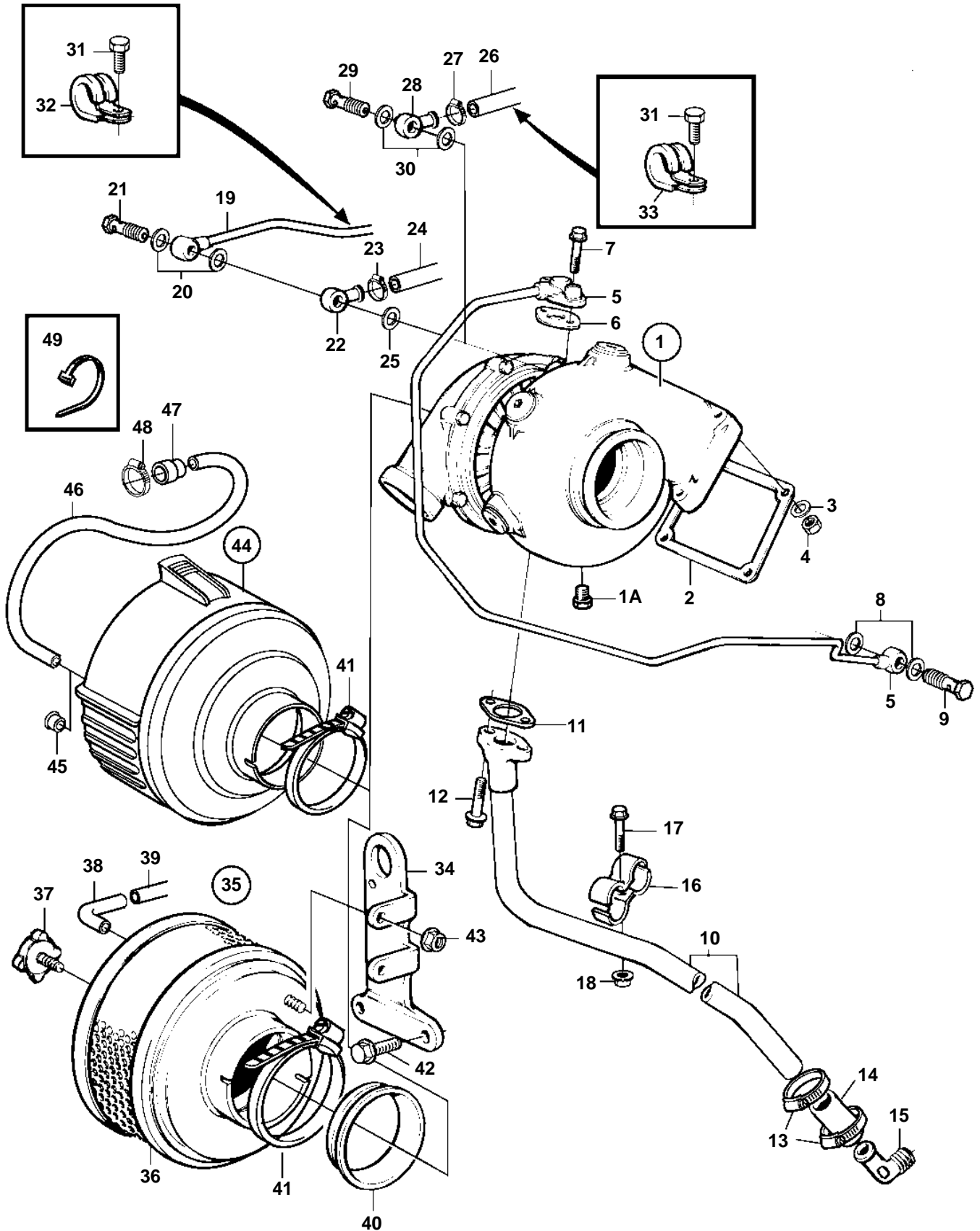

18260

## TAMD42WJ-A

REF	PART NO.	QTY	DESCRIPTION	SEE SEC.	NOTES
1	861260	1	Turbo		
	3802070	1	Turbocharger, exch		Exchange unit
				1697	
1A	861551	1	Plug		
2	3582676	1	Gasket		(859111)
3	955895	4	Washer		
4	940183	4	Nut		
5	838869	1	Oil feed pipe		
6	420641	1	Gasket		
7	945444	1	Flange screw		L=25mm
	946671	1	Flange screw		L=30mm
8	969011	2	Gasket		
9	25167	1	Hollow screw		
10	838820	1	Oil return pipe		
11	860105	1	Gasket		
12	945444	2	Flange screw		
13	943474	2	Hose clamp		
14	466328	1	Rubber hose		
15	983105	1	Elbow nipple		(843879)
16	820851	2	Clamp		
17	946544	1	Flange screw		
18	945407	1	Flange nut		
19	860214	1	Air vent hose		Turbo-thermostat housing.. For earlier version of expansion tank.
20	11994	2	Gasket		
21	947975	1	Hollow screw		
22	858750	1	Banjo nipple		
23	945652	2	Hose clamp		
24	942700	X	Hose		Expansion tank-Turbo.. For earlier version of expansion tank.
25	11994	1	Gasket		
26	942700	X	Hose		L=580mm. Expansion tank-Turbo.. For later version of expansion tank.
27	945652	2	Hose clamp		
28	858750	1	Banjo nipple		
29	969299	2	Hollow screw		
30	11994	2	Gasket		
31	967949	2	Screw		(965175)
32	952624	1	Clamp		
33	952627	1	Clamp		
34	838829	1	Bracket		
35	861434	1	Air filter		REPL BY 3582367
			Bulletin 44-47	44-47-EN	New Air Filter for 31, 41 and TAMD42WJ Engines
36	858488	1	· Filter insert		
37	859729	1	· Knob		
38	861391	1	· Rubber sleeve		
39	946234	X	Pipe		L=670mm
40	838855	1	Sealing ring		
41	943481	1	Hose clamp		
42	946329	2	Flange screw		L=25mm
43	945407	2	Flange nut		
44	3582367	1	Air filter kit		
			Bulletin 44-47	44-47-EN	New Air Filter for 31, 41 and TAMD42WJ Engines
45		1	· Plastic plug		
46		X	· Tube		L=670mm
47	861114	1	· Rubber sleeve		
48	943472	1	· Hose clamp		
49	948211	1	· Strip clamp		