

D9A2A D9-425, D9A2A D9-500 (R4), D9A2A D9-575, D9A2B 425, D9A2B D9-500 (R5), D9A2B D9-575, D9A2A D9A-MH, D9A2B MH

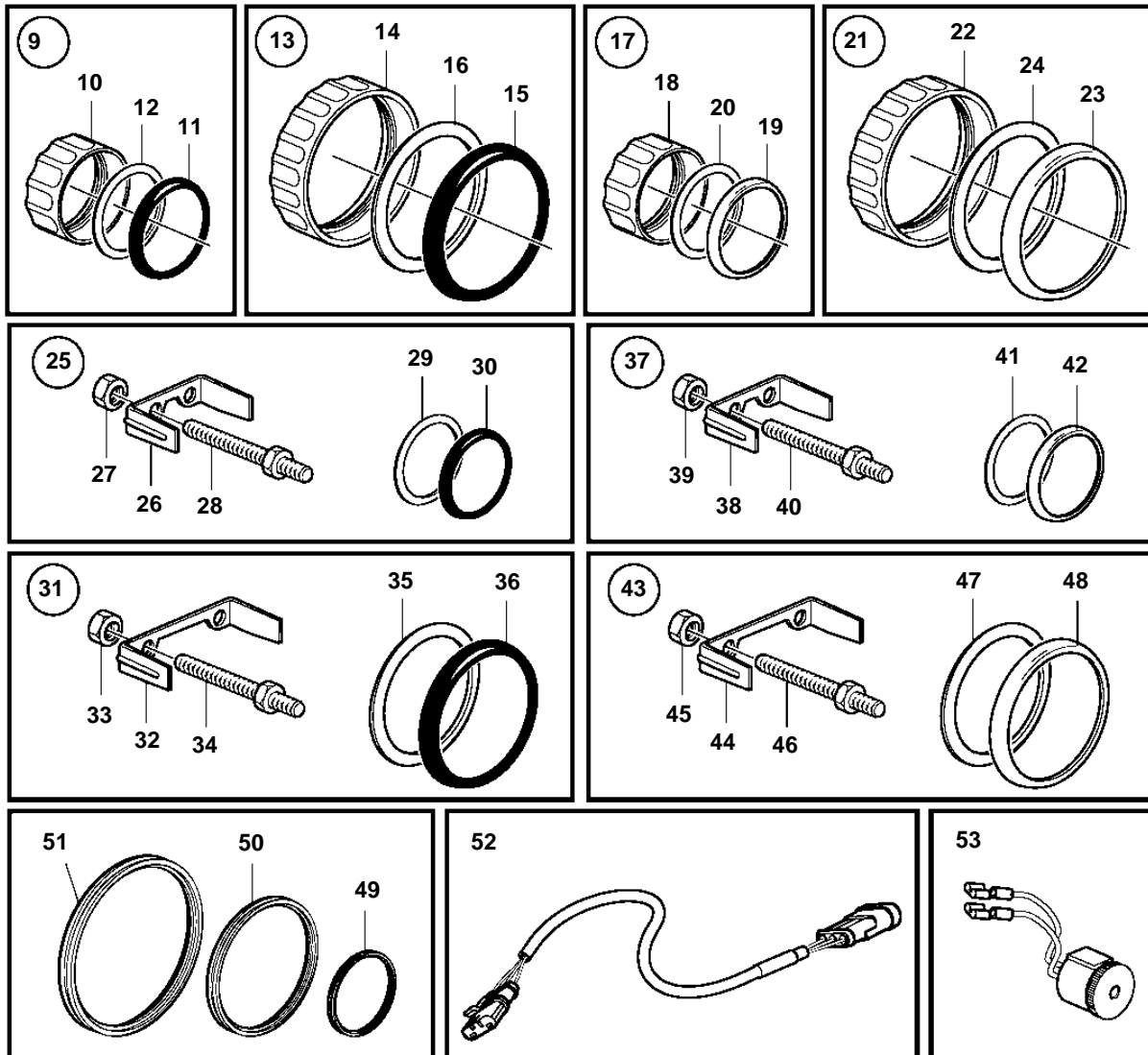

D9A2A D9-425, D9A2A D9-500 (R4), D9A2A D9-575, D9A2B 425, D9A2B D9-500 (R5), D9A2B D9-575, D9A2A D9A-MH, D9A2B MH

REF	PART NO.	QTY	DESCRIPTION	SEE SEC.	NOTES
1	881646	1	Tachometer		Engine speed/hours, Black D=85mm
	881652	1	Tachometer		Engine speed/hours, WHITE D=85mm
2	874908	1	Oil pressure gauge		BLACK 0-7 bar
	874919	1	Oil pressure gauge		Black 0-100 psi
	874923	1	Oil pressure gauge		WHITE 0-7 bar
	874932	1	Oil pressure gauge		WHITE 0-100 psi
3	874904	1	Thermometer, coolant water		Black 0-120°C
	874921	1	Thermometer, coolant water		White 0-120°C
	874918	1	Thermometer, coolant water		Black 40-250 °F
	874931	1	Thermometer, coolant water		White 40-250 °F
	881857	1	Thermometer, oil		BLACK 40-300 °F
	881858	1	Thermometer, oil		WHITE 40-300 °F
4	881649	1	Voltmeter		12V, Black
	881658	1	Voltmeter		12V, White
	874913	1	Voltmeter		24V, BLACK
	874925	1	Voltmeter		24V, WHITE
5	874915	1	Instrument, alarm		Black D=52mm
	874927	1	Instrument, alarm		White D=52mm
6	874914	1	Fuel gauge		Black D=52mm
	874926	1	Fuel gauge		White D=52mm
7	874910	1	Turbo pressure gauge		Black 0-3 bar
	874920	1	Turbo pressure gauge		BLACK 0-45 PSI
	874924	1	Turbo pressure gauge		WHITE 0-3 bar
	874933	1	Turbo pressure gauge		WHITE 0-45 PSI
8	3885214	1	Instrument		Four in one gauge (oil pressure, coolant temp, fuel level, volt meter)
			• Bulletin P-36-9-3	P-36-9-3-EN	New products in the EVC family
9	874709	1	Mounting kit		Black D=52mm
10	874450	1	• Attaching ring		
11	874448	1	• Ring		
12	874707	1	• Gasket		
13	874708	1	Mounting kit		Black D=85mm
14	874449	1	• Attaching ring		
15	874447	1	• Ring		
16	874706	1	• Gasket		
17	874733	1	Mounting kit		Chrome D=52mm
18	874450	1	• Attaching ring		
19	874731	1	• Ring		
20	874707	1	• Gasket		
21	874732	1	Mounting kit		Chrome D=85mm
22	874449	1	• Attaching ring		
23	874730	1	• Ring		
24	874706	1	• Gasket		
25	881611	1	Brace kit		Black D=52mm
26	881607	1	• Brace		
27	881610	2	• Nut		
28	881609	2	• Stud		
29	874707	1	• Gasket		
30	874448	1	• Ring		
31	881612	1	Brace kit		Black D=85mm
32	881608	1	• Brace		
33	881610	2	• Nut		
34	881609	2	• Stud		
35	874706	1	• Gasket		
36	874447	1	• Ring		
37	881613	1	Brace kit		Chrome D=52mm
38	881607	1	• Brace		
39	881610	2	• Nut		
40	881609	2	• Stud		
41	874707	1	• Gasket		
42	874731	1	• Ring		
43	881614	1	Brace kit		Chrome D=85mm
44	881608	1	• Brace		

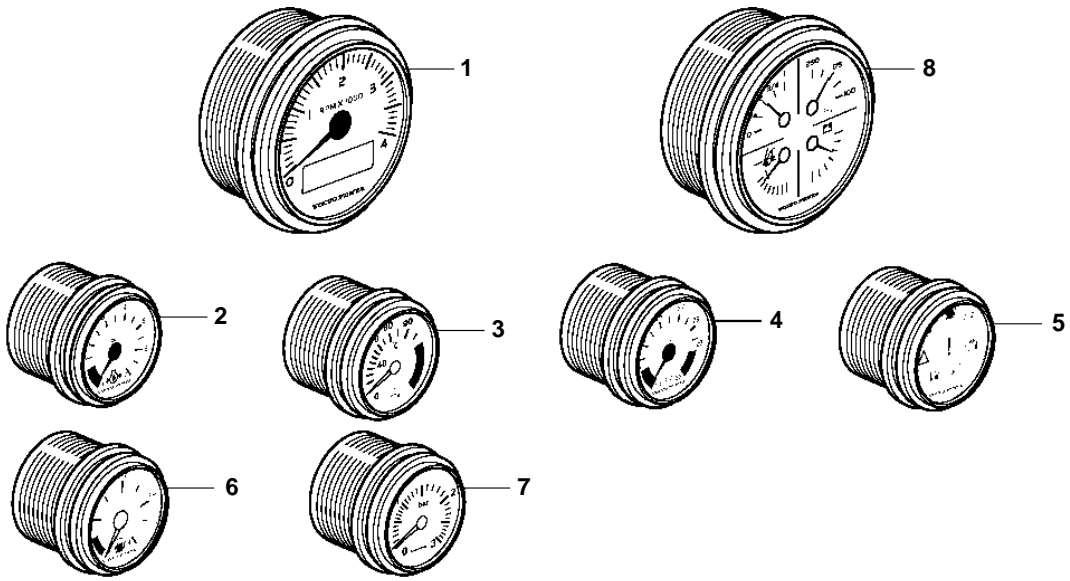