

D16C-A MH, D16C-B MH, D16C-C MH

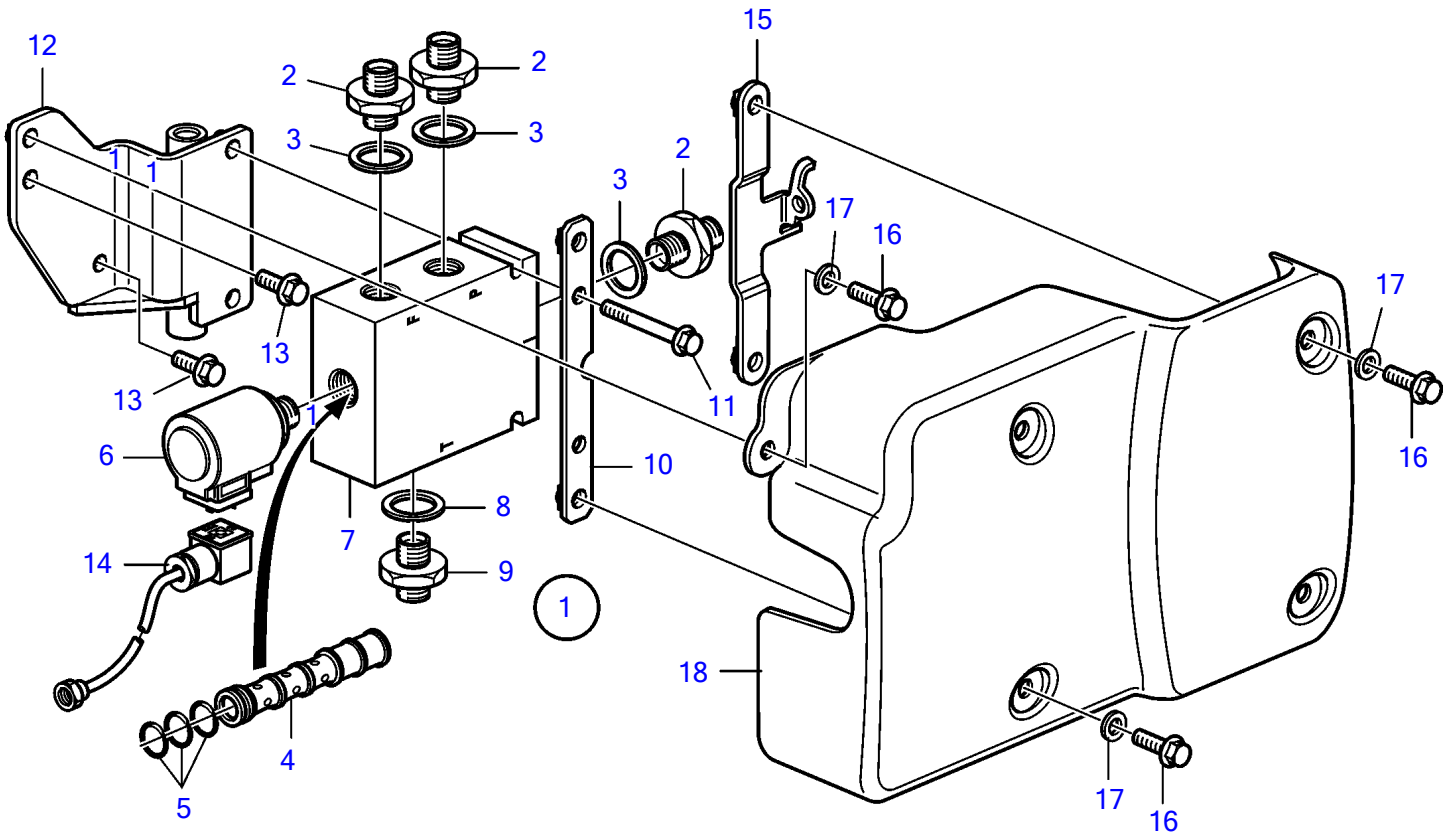

23225

D16C-A MH, D16C-B MH, D16C-C MH

REF	PART NO.	QTY	DESCRIPTION	NOTES
1	3835754	1	Fuel valve	
2	983388	3	• Nipple	
3	3889284	3	• Gasket	
4	3835759	1	• Valve	Repl by 3835754
5	3835803	2	• Gasket kit	
6	3835762	2	• Magnet	
7	(3835761)	2	• Manifold	Obsolete part, Repl by 3835754
8	3889284	1	Gasket	
9	983388	1	Nipple	
10		1	Bracket	
11	965181	2	Flange screw	
12		1	Bracket	
13	946440	2	Flange screw	
14	866664	1	Housing	
15	3884960	1	Bracket	
16	946173	5	Flange screw	
17	191172	5	Washer	
18	3842330	1	Protecting plate	