

D16C-A MH, D16C-B MH, D16C-C MH

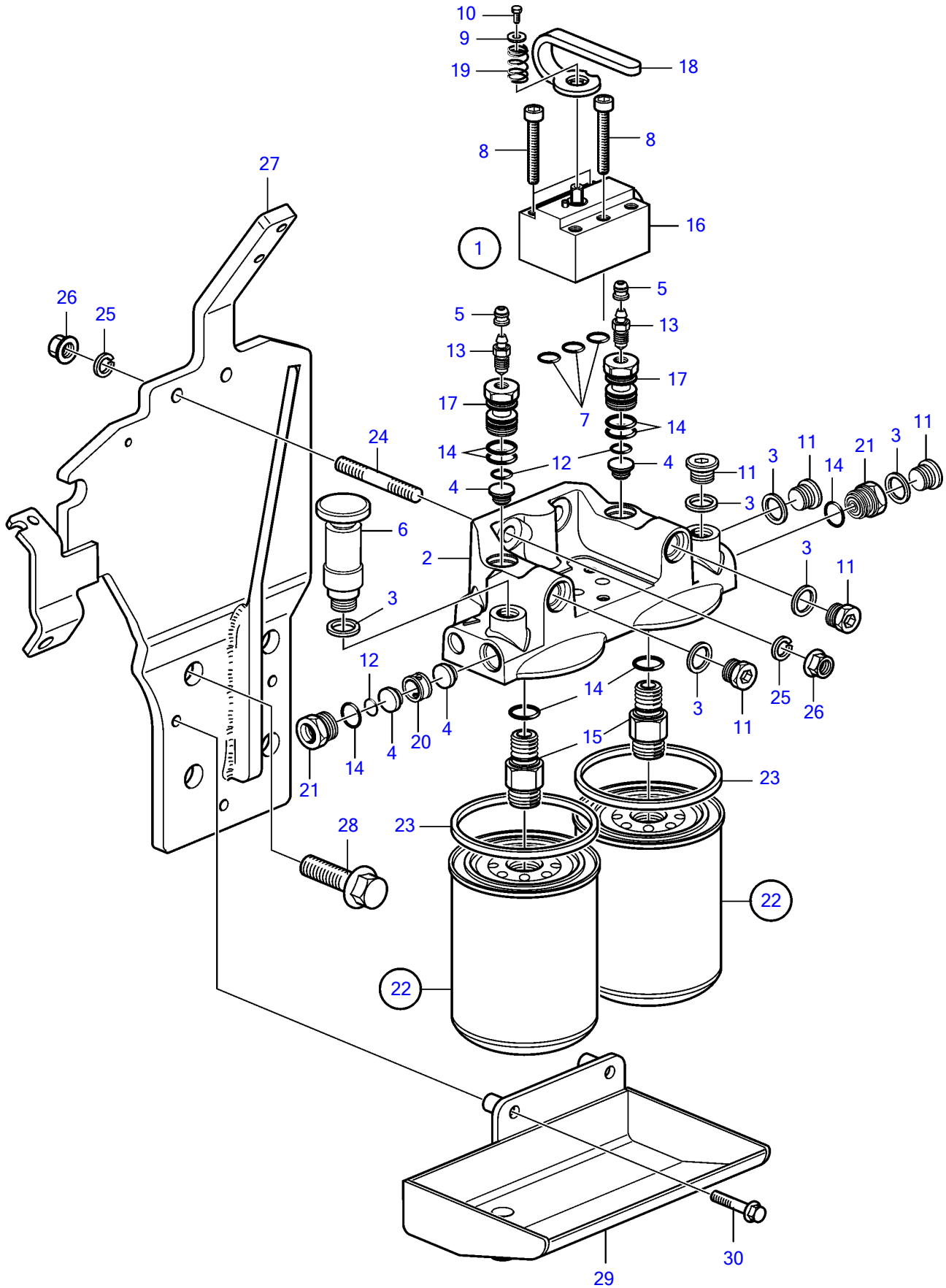

D16C-A MH, D16C-B MH, D16C-C MH

REF	PART NO.	QTY	DESCRIPTION	NOTES
1	3889532	1	Fuel filter housing	(3842872)
2	3808691	1	• Fuel filter housing	
3	11996	5	• Gasket	
4	244834	4	• Valve	
5	20547976	2	• Protecting cover	
6	3837393	1	• Hand pump	
7	944364	3	• O-ring	
8	959227	3	• Hex. socket screw	
9	3839116	1	• Cap washer	
10	963537	1	• Hexagon screw	
11	966143	5	• Plug	
12	976971	3	• O-ring	
13	20548012	2	• Faucet	
14	1526474	8	• O-ring	
15	3831210	2	• Nipple	
16	3835369	1	• Valve body	
17	3835370	2	• Nipple	
18	3842870	1	• Handle	
19	3842868	1	• Compression spring	
20	3964717	1	• Spacer sleeve	
21	8148328	2	• Nipple	
22	3888460	2	Fuel filter	
23		2	• Gasket	
24	977297	2	Stud	
25	941908	2	Spring washer	
26	971095	2	Flange nut	
27	40005169	1	Bracket	
28	968435	4	Flange screw	
29		1	Bracket	
30	947760	3	Flange screw	