

D16C-A MH, D16C-B MH, D16C-C MH

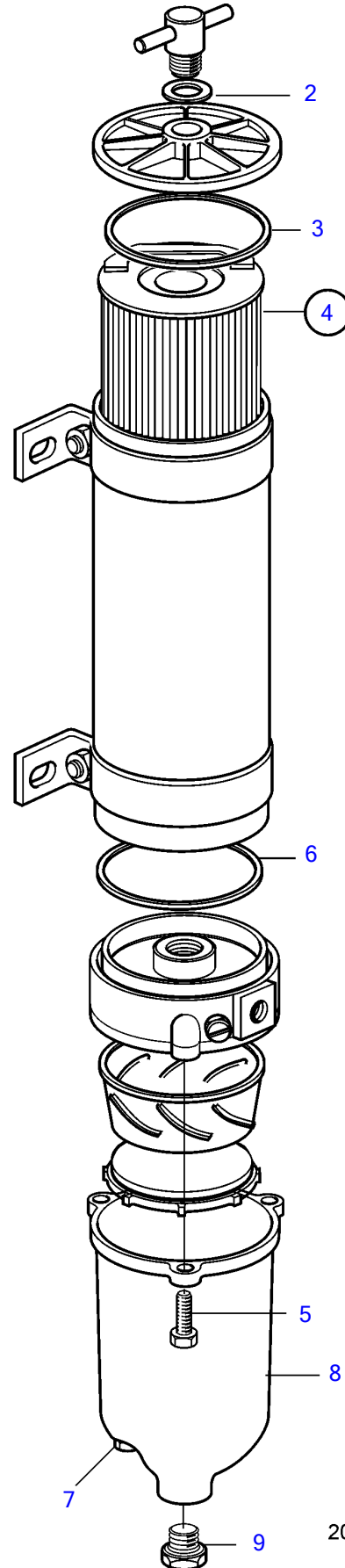
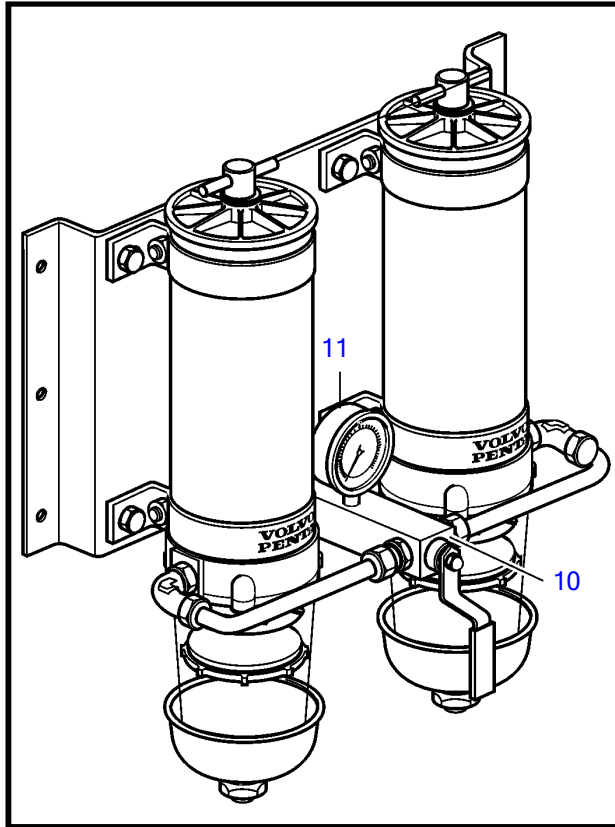

20359

D16C-A MH, D16C-B MH, D16C-C MH

REF	PART NO.	QTY	DESCRIPTION	NOTES
1	889281	1	Fuel filter	Metal bowl/heat shield. flow max. 1363l/h
2	838506	2	• O-ring	
3	846719	2	• Gasket	
4	3838854	2	• Fuel filter insert	
5	940094	2	• Hexagon screw	
6	846719	2	• Gasket	
7	952075	2	• Plug	
8	3838851	2	• Bowl	
9	952075	2	• Plug	
10	3827300	2	• Block	
11	3827299	2	• Manometer	