

D13B-E MH

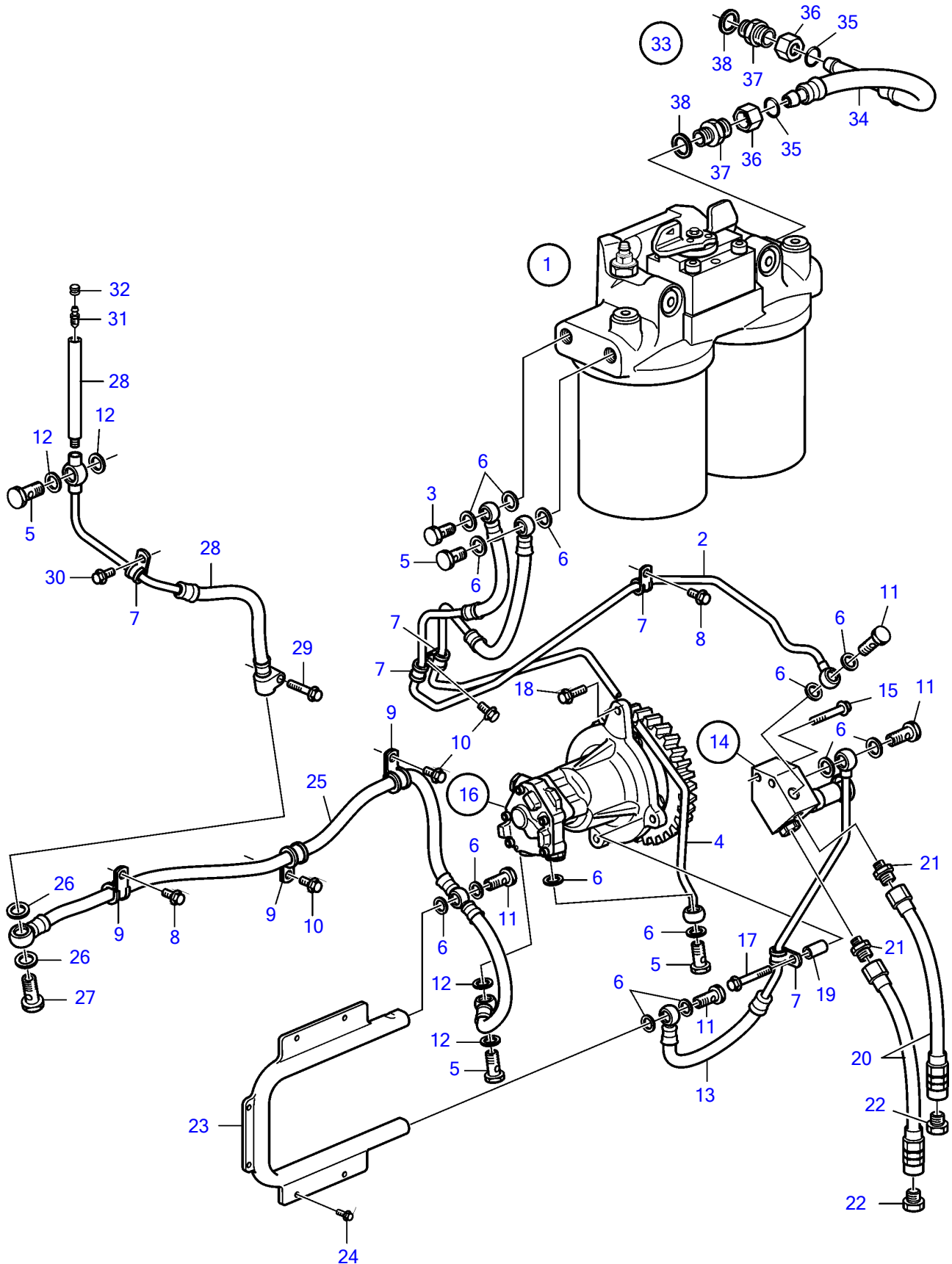

D13B-E MH

REF	PART NO.	QTY	DESCRIPTION	SEE SEC.	NOTES
1	21364381	1	Fuel filter housing	36882	
2	3889682	1	Fuel pipe		
3	3594288	1	Valve		
4	21385273	1	Air vent hose		
5	991046	3	Hollow screw		
6	20852764	16	Sealing ring		
7	942542	5	Clamp		
8	946471	1	Flange screw		
9	949747	3	Clamp		
10	946440	3	Flange screw		
11	991048	4	Hollow screw		
12	20852765	4	Sealing ring		
13	21163011	1	Fuel hose		
14	3889704	1	Housing	6876	
15	965216	2	Flange screw		
16	21635801	1	Fuel pump	6876	
17	965216	1	Flange screw		
18	946671	2	Flange screw		L=30mm
19	852660	1	Spacer sleeve		
20	3826595	2	Fuel hose		
21	977677	2	Nipple		
22	22753	2	Nipple		
23	20562394	1	Radiator		Replaced by 21251350
	21251350	1	Radiator		
24	946501	6	Flange screw		
25	21280354	1	Fuel hose		
26	20852765	2	• Sealing ring		
27	21088049	1	• Overflow valve		
28	21550182	1	Fuel hose		
29	947760	1	Flange screw		
30	947107	1	Flange screw		
31	20548012	1	Faucet		
32	20547976	1	Protecting cover		
33	21401343	1	Fuel hose		
34	3830315	1	• Hose		L=240mm
35	976971	2	• O-ring		
36	956984	2	• Fitting nut		
37	963948	2	Nipple		
38	20852765	2	Sealing ring		