

D13B-E MH

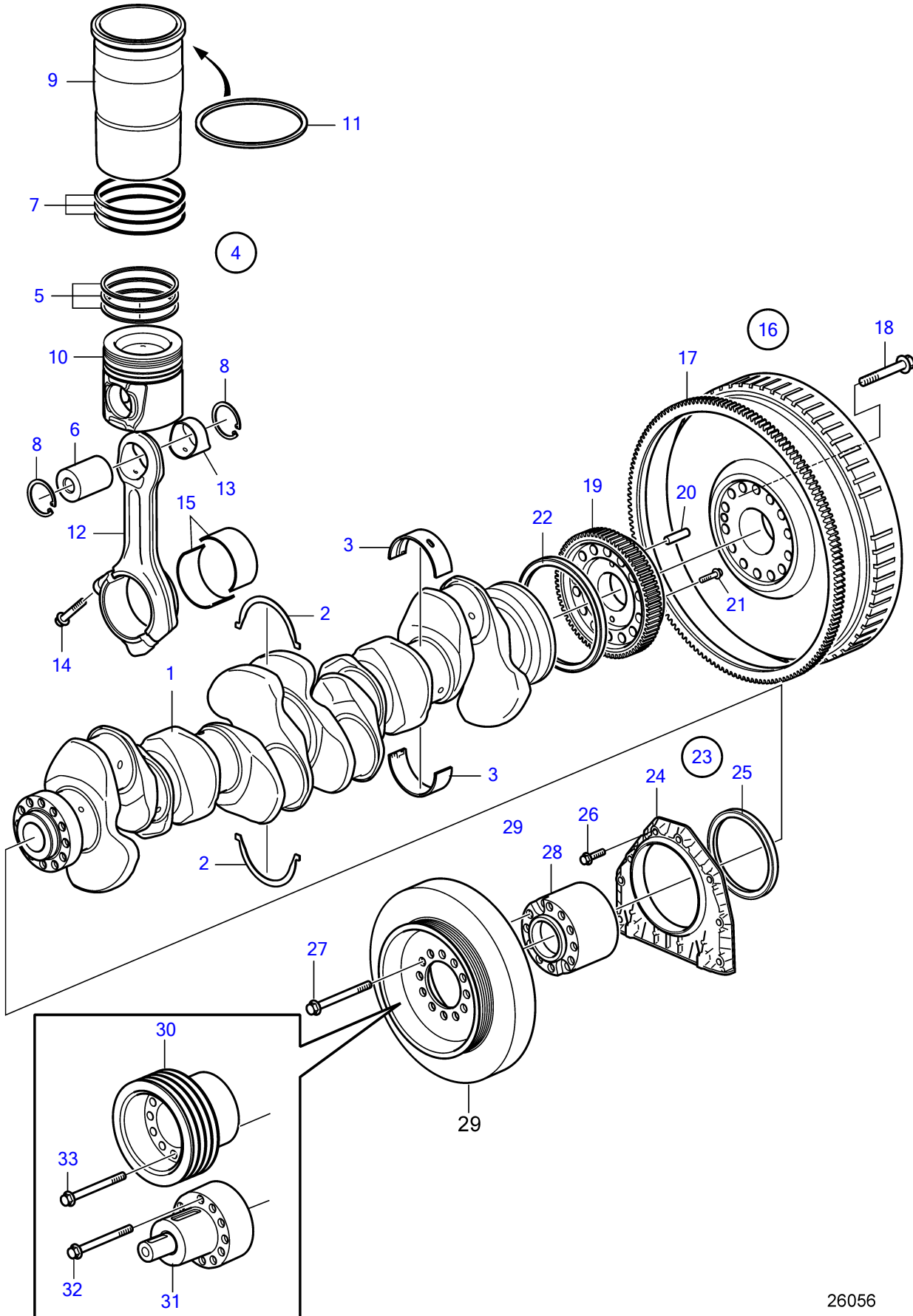

26056

D13B-E MH

REF	PART NO.	QTY	DESCRIPTION	NOTES
1	21230583	1	Crankshaft	
2	3093651	1	Thrust washer kit	Std
3	20530916	7	Main bearing	Std
4	21342695	6	Cylinder liner kit	
5	20747511	1	• Piston ring kit	
6		1	• Piston pin	
7	270950	1	• Sealing kit	
8	914531	2	• Snap ring	
9		1	• Cylinder liner	
10		1	• Piston	
11	1677591	X	Shim	TH=0,2mm
	1677592	X	Shim	TH=0,3mm
	1677593	X	Shim	TH=0,5mm
12	21261207	6	Connecting rod	
13	20730398	1	• Bushing	
14	20486228	4	• Flange screw	
15	20580558	6	Big-end bearing kit	Std
	20711963	6	Big-end bearing kit	O.S=0,25mm
	20711964	6	Big-end bearing kit	O.S=0,50mm
	20711966	6	Big-end bearing kit	O.S=1,00mm
16	21573048	1	Flywheel	
17	20711957	1	• Ring gear	(8193939)
18	21344746	14	Screw	
19	20743004	1	Gear	
20	950658	1	• Pin	
21	947760	2	Flange screw	
22	85108352	1	Crankshaft seal	
23	20777233	1	Cover	Replaced by 21054681
	21054681	1	Cover	
24		1	• Cover	
25	21347087	1	• Crankshaft seal	
26	946671	8	Flange screw	
27	965195	12	Flange screw	
28	21376964	1	Adapter	
29	3594670	1	Vibration damper	
30	21710847	1	Pulley	
31	21499128	1	Shaft	
32	970912	12	Hexagon screw	
33	981428	12	Hex. socket screw	