

D12D-A MH, D12D-B MH, D12D-C MH, D12C-A MP, D12D-A MP, D12D-B MP, D12D-C MP, D12D-D MP

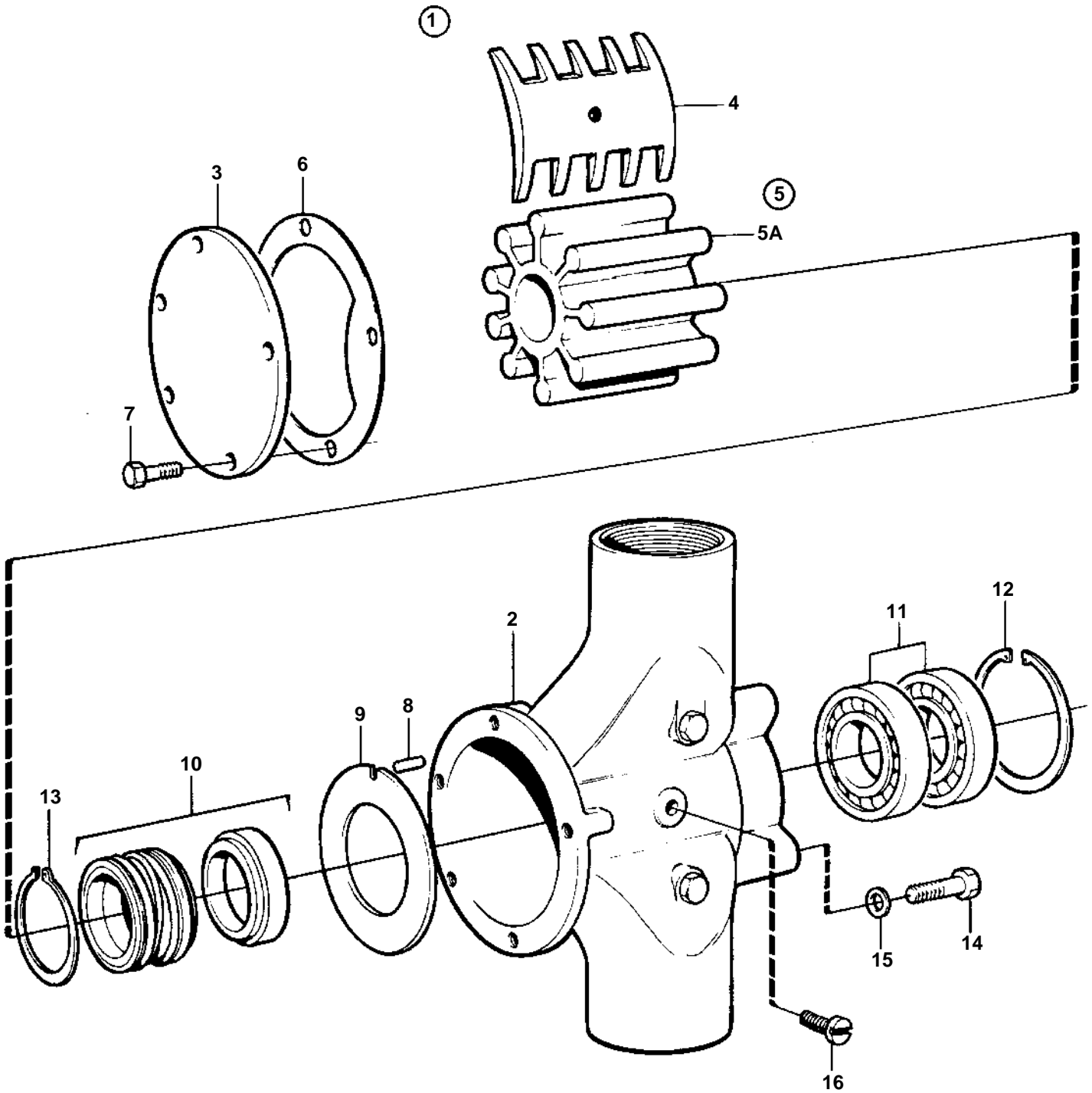

15308

D12D-A MH, D12D-B MH, D12D-C MH, D12C-A MP, D12D-A MP, D12D-B MP, D12D-C MP, D12D-D MP

REF	PART NO.	QTY	DESCRIPTION	NOTES
1	846105	1	Bilge pump	2"
2		1	· Pump housing	
3	825727	1	· Pump cover	
4	849322	1	· Cam	
5	875697	1	· Impeller kit	
5A		1	· · Impeller	
6	3829314	1	· · Gasket	
7	959931	5	· Hexagon screw	
8	826229	1	· Locking pin	
9	826230	1	· Wear washer	
10	822767	1	· Sealing	
11	181648	2	· Ball bearing	(1526189)
12	914533	1	· Snap ring	
13	943468	2	· Snap ring	
14	940135	4	· Hexagon screw	
15	941907	4	· Spring washer	
16	825730	1	· Screw	