

D12D-A MH, D12D-B MH, D12D-C MH, D12D-E MH, D12D-G MH, D12C-A MP, D12D-A MP, D12D-C MP

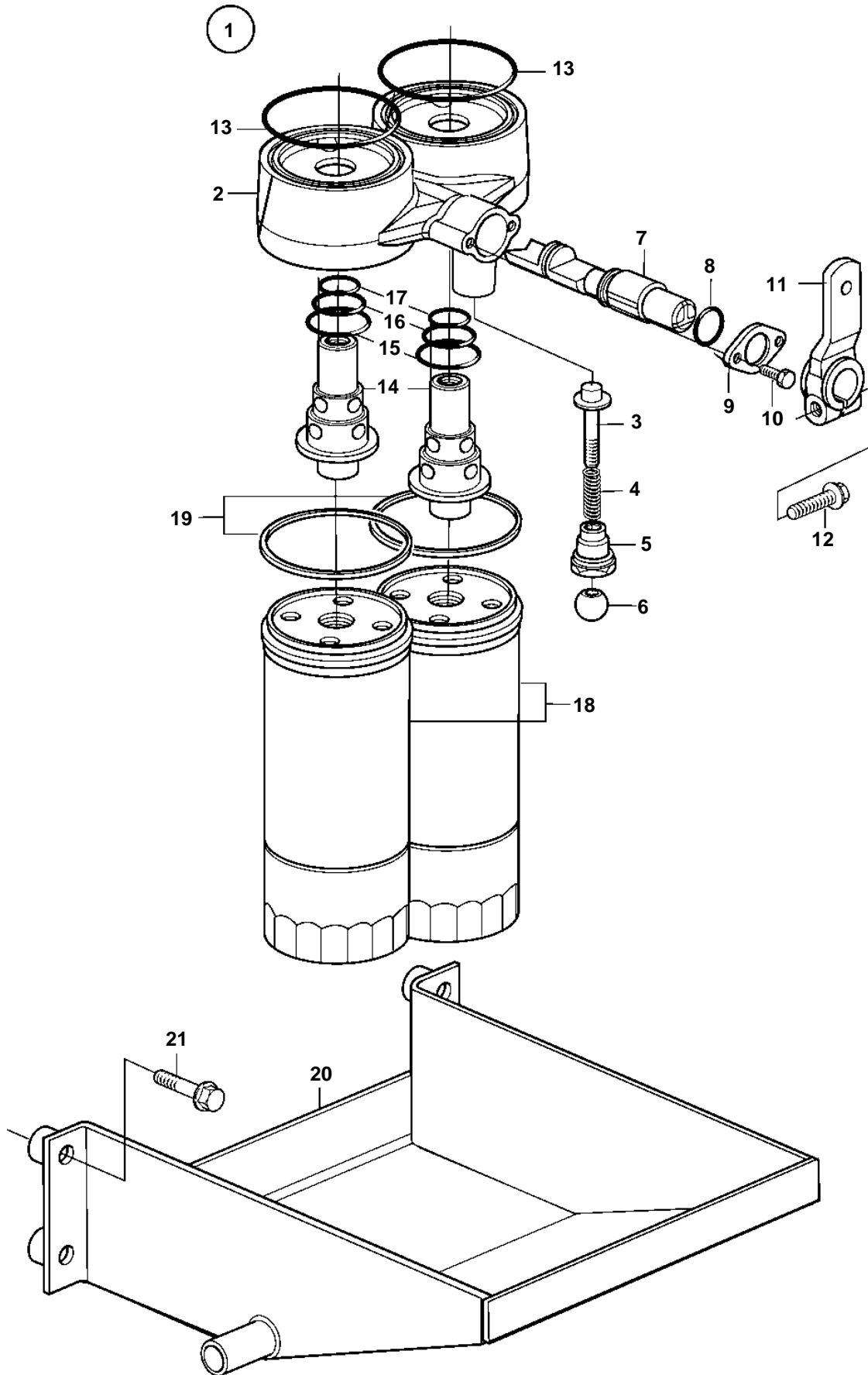

D12D-A MH, D12D-B MH, D12D-C MH, D12D-E MH, D12D-G MH, D12C-A MP, D12D-A MP, D12D-C MP

REF	PART NO.	QTY	DESCRIPTION	NOTES
1	3829976	1	Valve housing	
2			· Valve housing	
3	3830181	1	· Dowel	
4	466653	1	· Compression spring	
5	3830176	1	· Sleeve	
6	940344	1	· Handle ball	
7	3826152	1	· Shift valve	
8	949657	1	· O-ring	
9	842912	1	· Flange	
10	946544	2	· Flange screw	
11	964408	1	· Intermediate lever	
12	946752	1	· Flange screw	
13	948981	2	O-ring	
14	3829975	2	Nipple	
15	969415	2	O-ring	
16	948610	2	O-ring	
17	20536487	2	O-ring	(3165747)
18	478736	2	Oil filter	
19		2	· Gasket	
20	3832385	1	Spill plate	
21	945444	4	Flange screw	