

TAMD31L-A, TAMD31M-A, TAMD31P-A

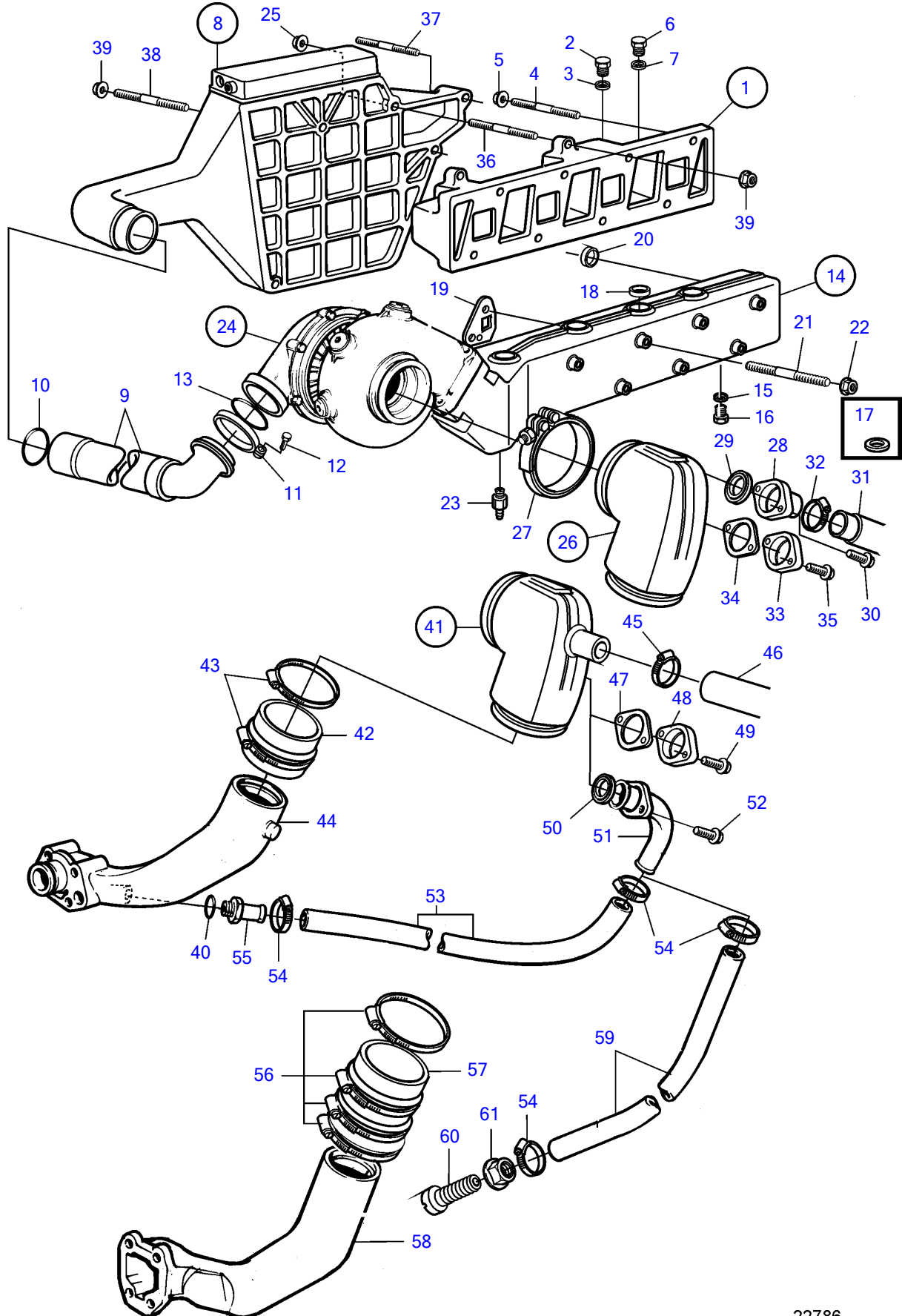

22786

TAMD31L-A, TAMD31M-A, TAMD31P-A

REF	PART NO.	QTY	DESCRIPTION	NOTES
1	859299	1	Inlet pipe	
2	960634	4	• Plug	
3	947627	4	• Gasket	
4	980226	6	Stud	
5	945408	6	Flange nut	
6	960632	1	Plug	
7	11998	1	Gasket	
8		1	Intercooler	
9	838693	1	Connection pipe	
10	864723	1	Sealing ring	
11	838864	1	V-band clamp	
12	947542	1	Flange screw	
13	967944	1	O-ring	
14	861619	1	Exhaust pipe	Repl by 876953
	876953	1	Exhaust pipe	Replaced by 3581549
	3581549	1	• Exhaust pipe	
15	957181	1	• Gasket	
16	960632	1	• Plug	
17	944563	1	• Spacer washer	
18	946780	7	Cap plug	For 861619
19	876144	4	Gasket kit	
20	838766	1	Sealing ring	
21	953007	1	Stud	For earlier version of expansion tank., L=150mm
	980835	1	Stud	For later version of expansion tank., L=155mm
	953003	1	Stud	L=130mm
	953001	2	Stud	For earlier version of expansion tank., L=120mm
	953001	1	Stud	For later version of expansion tank., L=120mm
	952999	4	Stud	L=110mm
	953005	1	Stud	For later version of expansion tank., L=140mm
22	971095	8	Flange nut	
23	949918	1	Shut-off cock	
24		1	Turbo	
25	945408	1	Flange nut	
26	859963	1	Exhaust riser	
27	842993	1	V-band clamp	
28	858659	1	Hose connection	
29	842913	1	Sealing ring	
30	946544	2	Flange screw	
31	944386	X	Rubber hose	Heat exchanger-exhaust riser., L=370mm
32	943475	1	Hose clamp	
33	844093	1	Flange	
34	859002	1	Gasket	
35	946544	2	Flange screw	
36	953049	2	Stud	L=50mm
37	984130	1	Stud	L=110mm (980227)
38	981440	1	Stud	L=185mm
39	945408	4	Flange nut	